

Project Manual

Proposal, General Conditions and Technical Specifications

City of Fostoria, Ohio

City of Fostoria, Ohio

ADA Compliant Sidewalk Ramps

along

**S Countyline Street from Findlay Street to Culbertson
Lane**

Seneca County Board of Commissioners - Owner
CDBG Small Cities Formula

Key Dates:

Date Prepared: May 12, 2022
Advertisement Dates: MAY 12TH AND 19TH, 2022

Bid Opening: MAY 26TH, 2022 10:15 a.m.

Amended:

May 19, 2022

Construction Bid Package

Table of Contents

TABLE OF CONTENTS	ii-iii
NOTICE TO BIDDERS, SECTION A	
Invitation to Bidders	A-1
INSTRUCTIONS TO BIDDERS, SECTION B	
1. Receipt and Opening of Bids	B-2
2. Preparation of Bid	B-2
3. Method of Bidding	B-2
4. Qualification of Bidder	B-2
5. Bid Security	B-2
6. Liquidated Damages for Failure to Enter into Contract.....	B-3
7. Conditions of Work.....	B-3
8. Obligation of Bidder.....	B-3
9. Examination of Site	B-3
10. Soil Conditions	B-3
11. Working Facilities	B-3
12. Addenda and Interpretations.....	B-3
13. Water Supply.....	B-3
14. Signature of Bidders.....	B-3
15. Notice of Special Conditions	B-3
16. Additional Obligations Upon Contract Award.....	B-4
17. Foreign Corporations, Individuals & Partnerships	B-4
GENERAL CONTRACT CONDITIONS, SECTION C	
Article 1 General Contract Documents	C-2
Article 2 Performance & Payment Bonds.....	C-2
Article 3 Wage Rates	C-2
Article 4 Affirmative Action	C-2
Article 5 Insurance.....	C-3
Article 6 Safety	C-4
Article 7 Permits	C-5
Article 8 Supervision	C-5
Article 9 Claims Against the Contractor	C-5
Article 10 Subcontracting	C-6
Article 11 Change of Work	C-6
Article 12 Time	C-6
Article 13 Completion of Work.....	C-7
Article 14 Termination	C-7
Article 15 Payment	C-7
Supplemental General Conditions	C-8

Construction Bid Package

PROPOSAL FORMS, SECTION D

Bid for Lump Sum Contracts D-2
 Signature Page D-3
 Bid Bond D-4
 Non-Collusion Affidavit..... D-6
Bonding & Insurance Requirements D-7

CONTRACT, SECTION E

Article 3 Contract E-2
 Signature Page E-3
 Certification E-3
Notice of Award and Acceptance of Notice..... E-4
Notice to Proceed and Acceptance of Notice E-5
Affidavit of Contractor or Supplier of Non-Delinquency
 of Personal Property Taxes E-6
Change Order E-7
Non-Discrimination Statement E-8
Certificate of Owner's Attorney..... E-9
Certificate of Owner's Financial Officer E-10

FEDERAL AND STATE REQUIREMENTS, SECTION F

Conflict of Interest F-2
Special Conditions Pertaining to Hazards,
 Safety Standards and Accident Prevention F-2
Special Equal Opportunity Provisions F-3
Section 3 Plan Format..... F-12
Table A - Proposed Subcontractors Breakdown F-14
Table B - Estimated Project Workforce Breakdown F-15
Certification of Bidder Regarding Equal Employment Opportunity F-16
Certification of Subcontractor Regarding Equal Employment Opportunity F-17
Certification of Bidder Regarding Section 3-Segregated Facilities F-18
Certification of Subcontractor Regarding Section 3-Segregated Facilities F-19
Certification of Compliance with Air & Water Acts F-20
Architects Certification for Compliance with Minimum
 Standards for Accessibility by the Physically Handicapped..... F-21

FEDERAL LABOR STANDARDS PROVISIONS, SECTION G..... G-2

Contractor's Certification Concerning Labor Standards &
 Prevailing Wage Requirements..... G-10
Contractor's Certification Concerning Labor Standards &
 Prevailing Wage Requirements..... G-12
Certification of Compliance with Federal Labor Standards Provision G-14
Certification of Compliance with Section 3517.13 of the Ohio Revised Code G-15
Federal Davis-Bacon Wage Decision Section

NOTICE TO BIDDERS
SECTION

NOTICE TO BIDDERS

Sealed bids for the **City of Fostoria ADA Compliant Sidewalk Ramp Program** will be received in the office of the Seneca County Commissioners @ 111 Madison Street, Tiffin Ohio 44883, until 10:15 a.m. (local time) on May 26, 2022 at which time and place they will be publicly opened and read aloud.

The opinion of probable construction cost is \$46,930.00.

Copies of the detailed plans, specifications and contract documents may be obtained or examined at the office of the Seneca Regional Planning Commission, 71 S Washington St, Tiffin, Oh 44883 between 9:00 a.m. and 3:00 p.m. on Monday thru Friday. Questions shall be directed to Seneca Regional Planning Commission at (419) 443-7936 ext 1123 or emailed to cjwatkins@senecarpc.org.

A complete set of Bid Documents may be obtained from Seneca Regional Planning Commission for a non-refundable fee of \$10.00 made payable to Seneca County Treasurer. Documents will be shipped, by FedEx only, with an additional payment to the Treasurer in the amount of \$5.00 or with a valid FedEx account number provided to Seneca Regional Planning Commission for the shipping charge.

Should a bidder find any discrepancies in or omissions from any of the documents, or be in doubt as to their meaning, he shall advise the Engineer in writing, who will issue necessary addenda, or revised drawings, as may be appropriate. However, no request for clarification/information will be accepted after three (3) days before the date on which bids are due.

Attention of the Bidder is directed to the special requirements for wage rates, the hours of employment as ascertained and determined by the Federal Labor Standards Provisions, including Davis-Bacon wage rates and provided for in the laws of the State of Ohio.

Successful Bidder must be an Equal Employment Opportunity Employer, which prohibits discrimination based on race, creed, color, national origin, sex, age, handicap, political affiliation, or beliefs.

Proposals must be submitted on the form furnished and must contain the name of every person, firm or corporation interested therein. Bids shall be sealed and marked as **“City of Fostoria ADA Compliant Sidewalk Ramp Program”** and mailed or delivered as directed above.

Bidders are required to file with their bid a Penal Bond in the amount of 10% of the bid or a certified check, a cashier's check or a letter of credit pursuant to Chapter 1305 of the Ohio Revised Code in the amount of 10% of the bid. The proposal bond or certified check submitted with the bid will be held as a guarantee that if the proposal is accepted, a contract will be entered into. Proposal bonds and certified checks will be returned to all Bidders after the contract has been entered into and secured by a performance and payment bond of 100% of the contract with a satisfactory surety for the faithful performance of the work.

The successful bidder will be required to execute an affidavit relative to delinquent personal property taxes pursuant to the provisions of Section 5719.042 of the Ohio Revised Code prior to entering into a contract.

No Bid may be withdrawn within 30 days after the actual date of the bid opening.

The Seneca County Board of Commissioners (Owner) intends to accept the lowest and best bidder for the project but reserves the right to reject any and all, or parts of any or all bids and to waive any minor informalities in any bid, or to make the award in the best interest of the Owner.

Award of contract is also subject to the following provisions:

Debarment, Suspension, Ineligibility and Voluntary Exclusion – 49 CFR Part 29.

Domestic steel use requirements as specified in Ohio Revised Code § 153.011

Buy Ohio Preferences: To the extent practicable, use Ohio products, materials, services and labor

Ohio Revised Code § 164.05 (A)(6)

Advertise:

May 12th & May 19th, 2022

INSTRUCTIONS TO BIDDERS

SECTION B

Construction Bid Package

Construction Bid Package

INSTRUCTIONS TO BIDDERS

1. **RECEIPT AND OPENING OF BIDS:** The Seneca County Board of Commissioners (herein called the "Owner"), invites bids on the form attached hereto, all blanks of which must be appropriately filled in. Bids will be received by the Owner at the office 111 Madison St., Tiffin OH until May 26, 2022 at 10:15 a.m., and then publicly opened and read aloud. The envelopes containing the bids must be sealed, addressed to the Seneca County Board of Commissioners and designated as **BID FOR CITY OF FOSTORIA ADA COMPLIANT SIDEWALK RAMP PROGRAM - DO NOT OPEN.**

The Owner may consider informal any bid not prepared and submitted in accordance with the provisions hereof and may waive any informalities or reject any and all bids. Any bid may be withdrawn prior to the above scheduled time for the opening of bids or authorized postponement thereof. Any bid received after the time and date specified shall not be considered. No bidder may withdraw a bid within thirty (30) days after the actual date of the opening thereof.

2. **PREPARATION OF BID:** Each bid must be submitted on the prescribed form and accompanied by a Bid Bond, Certified Check, Cashier's Check or Letter of Credit, the Noncollusion Affidavit, and the Statement on Delinquent Taxes. All blank spaces for bid prices must be filled in, in ink or typewritten, in both words and figures, and the foregoing Certifications must be fully completed and executed when submitted. In case of discrepancies of written words and figures, the prices written in words shall govern.

Each bid must be submitted in a sealed envelope bearing on the outside the name of the bidder, his/her address, and the name of the project for which the bid is submitted. If forwarded by mail, the sealed envelope containing the bid must be enclosed in another envelope addressed as specified.

3. **METHOD OF BIDDING:** The Owner invites lump sum bids as indicated in the Bid Form, page D-2

If the lowest total responsive bid received exceeds the amount of funds available to finance the contract, the Owner may:

- a. Reject all bids;
- b. Augment the funds available in an amount sufficient to enable award to the lowest responsive bidder or bidders;
- c. Take the base bid less a number of items as listed on the proposal form as to produce a net amount which is within available funds.

The specifications on this project are part of the construction drawings and are shown on page **A3.0.**

5. **QUALIFICATIONS OF BIDDER:** The Owner may make such investigations as deemed necessary to determine the ability of the bidder to perform the work, and the bidder shall furnish to the Owner all such information and data for this purpose as the Owner may request. The Owner reserves the right to reject any bid if the evidence submitted by, or investigation of, such bidder fails to satisfy the Owner that such bidder is properly qualified to carry out the obligations of the contract and to complete the work contemplated therein. Conditional bids will not be accepted.
6. **BID SECURITY:** Each bid must be accompanied by certified check, cashier's check, letter of credit, or a bid bond prepared on the form of bid bond attached hereto, duly executed by the bidder as principal and having as surety thereon a surety company approved by the Owner, in the amount of 10% of the bid. Such checks or bid bonds will be returned to all except the three lowest

Construction Bid Package

bidders within three days after the opening of bids, and the remaining, checks or bid bonds will be returned promptly after the Owner and the accepted bidder have executed the contract, or, if no award has been made within thirty (30) days after the date of the opening of bids, upon demand of the bidder at any time thereafter, so long as he/she has not been notified of the acceptance of his/her bid. Attorneys-in-fact who sign bid bonds or contract bonds must file with each bond a certified and effectively dated copy of their power of attorney.

7. **LIQUIDATED DAMAGES FOR FAILURE TO ENTER INTO CONTRACT:** The successful bidder, upon failure or refusal to execute and deliver the contract and bonds required within ten (10) days after receipt of notice of the acceptance of the bid, shall forfeit to the Owner, as liquidated damages for such failure or refusal, the security deposited with the bid.
8. **CONDITIONS OF WORK:** Each bidder must be fully informed of the conditions relating to the completion of the project. Failure to do so will not relieve a successful bidder of any obligation to furnish all material and labor necessary to carry out the provisions of the contract. Insofar as possible, the contractor in carrying out the work, must employ such methods or means as will not cause any interruption of or interference with the work of any other contractor.
9. **OBLIGATION OF BIDDER:** At the time of the opening of bids each bidder will be presumed to have read and to be thoroughly familiar with the plans and contract documents (including all addenda). The failure or omission of any bidder to examine any form, instrument or document shall in no way relieve any bidder from any obligation in respect to the bid.
10. **EXAMINATION OF SITE:** Each bidder shall, and is hereby directed to inspect the entire site of the proposed work and judge as to all the circumstances affecting the cost and progress of the work and shall assume all patent and latent risks in connection therewith.
11. **WORKING FACILITIES:** The plans show, in the general manner, the existing structure for construction purposes. The bidders must satisfy themselves of the conditions and difficulties that may be encountered in the execution of the work at this site.
12. **ADDENDA AND INTERPRETATIONS:** No official interpretation of the meaning of the plans, specifications or other pre-bid documents will be made to any bidder orally. Every request for such interpretation should be in writing addressed to Seneca Regional Planning Commission, 71 S Washington St, Suite 1104, Tiffin, OH 44883 and to be given consideration, must be received at least five (5) days prior to the date fixed for the opening of bids. Any and all such interpretations and any supplemental instructions will be in the form of written addenda to the specifications which, if issued, will be email or faxed with return receipt requested to all prospective bidders (at the respective addresses furnished for such purposes), not later than three (3) days prior to the date fixed for the opening of bids. Failure of any bidder to receive any such addendum or interpretation shall not relieve such bidder from any obligation under the bid as submitted. All addenda so issued shall become part of the contract documents.
13. **SIGNATURE OF BIDDERS:** The firm, corporate or individual name of the bidder must be signed in blue ink in the space provided for the signatures on the proposed blanks. In the case of a corporation, the title of the officer signing must be stated and such officer must be thereunto duly authorized and the seal of said corporation duly affixed. In the case of a partnership, the signature of at least one (1) of the partners must follow the firm name, using the term "member of the firm". In the case of an individual, use the terms "doing business as", or "sole owner". The bidder shall further state in his proposal the name and address of each persons or corporation interested therein and also provide a valid email address.
14. **NOTICE OF SPECIAL CONDITIONS:** Attention to the bidder is particularly called to those parts of the General Contract Conditions and other contract documents and specifications which deal

Construction Bid Package

with the following:

- a. Insurance requirements;
- b. Federal Labor Standards Provisions, including Davis-Bacon wage rates;
- c. Requirement for a payment bond and performance bond for 100% of contract price;
- d. Requirement that all subcontractors be approved by the Owner;
- e. Time-for-completion and liquidated damages requirements; and/or
- f. Safety standards.

17. **ADDITIONAL OBLIGATIONS UPON CONTRACT AWARD:** Upon award of the contract, but prior to execution of the final agreement and notice to proceed, the contractor shall submit the following documents, completed as required:

- a. Acceptance of Notice of Award
- b. Contract
- c. Insurance certificate(s) and/or policy(ies)
- d. Contractor's Section 3 Plan
- e. Certification of Bidder Regarding Equal Employment Opportunity
- f. Certification of Bidder Regarding Section 3 and Segregated Facilities
- g. Contractor's Certification(s) Concerning Labor Standards & Prevailing Wage Requirements.

18. **FOREIGN CORPORATIONS AND CONTRACTORS:**

- A. Foreign Corporations:

Definition: "Foreign Corporation" means a corporation incorporated under the laws of another state. No contract shall be entered into with a foreign corporation until the Secretary of State has certified that such corporation is authorized to do business in Ohio; and until, if the bidder so awarded the Contract is a person or partnership, it has filed with the Secretary of State a Power of Attorney designating the Secretary of State as its agent for the purpose of accepting service of summons in any action brought under Section 153.05 of the Ohio Revised Code or under Sections 4123.01 to 4123.94, inclusive of the Revised Code.

GENERAL CONTRACT CONDITIONS

SECTION C

Construction Bid Package

Construction Bid Package

GENERAL CONTRACT CONDITIONS

ARTICLE 1 - CONTRACT AND CONTRACT DOCUMENTS

- A. The project to be constructed pursuant to this contract will be financed with assistance from the Department of Housing and Urban Development and is subject to all applicable Federal laws and regulations.
- B. All applicable State laws, municipal ordinances, and the rules and regulations of all authorities having jurisdiction over construction of the project shall apply to the contract throughout, and they will be deemed to be included in the contract the same as though herein written out in full.
- C. The Plans, Specifications and Addenda, hereinafter enumerated in Paragraph 1 of the Supplemental General Conditions shall form part of this Contract and the provisions thereof shall be as binding upon the parties hereto as if they were herein fully set forth. The table of contents, titles, headings, running headlines and marginal notes contained herein and in said documents are solely to facilitate reference to various provisions of the Contract Documents and in no way affect, limit or cast light on the interpretation of the provisions to which they refer.

ARTICLE 2 - PERFORMANCE AND PAYMENT BONDS

Simultaneously with the delivery of the executed contract, the Contractor shall furnish a surety bond or bonds as security for faithful performance of this contract and for the payment of all persons performing labor on the project under this contract and furnishing materials in connection with this contract, as specified in the General Conditions included herein. The surety on such bond or bonds shall be a duly authorized surety company satisfactory to the Owner. The bond shall be for 100 percent (100%) of the contract price. A Payment Bond and Performance Bond are required. Attorneys-in-fact who sign bid bonds or contract bonds must file with each bond a certified and effectively dated copy of their power of attorney.

ARTICLE 3 - WAGE RATES

In the event that the rate of wages paid for any trade or occupant in the locality where such work is being performed are under current collective agreements or understandings between bona fide organizations of labor and employer, then the wages to be paid shall be not less than such agreed wage rates, nor less than the minimum rates compiled by the Federal Labor Standard Provision. A copy of these prevailing rates of wages has been included in these specifications.

Every Contractor and Subcontractor who is subject to this contract shall, as soon as they begin performance under the contract with the Owner, supply the Owner a schedule of the dates on which they are required to pay wages to employees. They shall also deliver to the prevailing wage coordinator within three weeks after each pay date, a certified copy of the payroll which shall exhibit for each employee paid any wages, name, current address, social security number, number of hours worked each day of the pay period and the total for each week, hourly rate of pay, job classification, fringe payments, and deductions from wages. The certification of each payroll shall be executed by the Contractor, Subcontractor, or duly appointed agent thereof and shall recite that the payroll is correct and complete and that the wage rate shown is not less than those required by the contract.

Inssofar as possible, local labor shall be employed on this work.

ARTICLE 4 - AFFIRMATIVE ACTION

Each bidder, Contractor or Subcontractor (hereinafter the Contractor) must fully comply with either

Construction Bid Package

Part 1 or Part 2, as applicable, of Executive Order 11246 as stated on page F-3 and F-4 during the performance of this contract or subcontract. The Contractor commits itself to the goals for minority manpower utilization in Part 1 or Part 2, as applicable, and all other requirements, terms and conditions of these bid conditions by submitting a properly signed bid.

The Contractor shall appoint a company executive to assume the responsibility for the implementation of the requirements, terms and conditions of these bid conditions.

ARTICLE 5 - INSURANCE

- A. The Contractor shall not commence work under this Contract until he has obtained all the insurance required hereunder and such insurance has been approved by the Owner, nor shall the Contractor allow any Subcontractor to commence work on his subcontract until all similar insurance required of the Subcontractor has been so obtained and approved. Approval of the insurance by the Owner shall not relieve or decrease the liability of the Contractor hereunder.
- B. The Contractor shall file with the Owner all Certificate(s) of Insurance as are necessary to document the insurance coverage required hereunder, subject to the approval of the Owner and receipt of any additional forms/documentation requested, prior to final execution of the Agreement Contract and issuance of the Notice to Proceed.
- C. Worker's Compensation. All contractors and subcontractors shall acquire and maintain, during the term of the Contract, Worker's Compensation insurance in full compliance with the laws of the State of Ohio.
- D. Contractor's Liability Insurance:
 - (i) The Contractor shall acquire and maintain during the term of the Contract Bodily Injury and Property Damage Liability Insurance under a standard Comprehensive General/Automobile Liability Policy which shall provide and include coverage on all Contractor's Operations, Contractor's Protective (Sublet) Liability, Contractual Liability, Completed Operations Liability, Owned Automobiles and Non-owned and Hired Automobiles.
 - (ii) Property Damage Liability Insurance shall be provided on any demolition, blasting, excavating, shoring or similar operation on an "if any" basis.
 - (iii) Bodily Injury Liability limits shall be for an amount of no less the Two Hundred and Fifty Thousand (\$250,000) Dollars for injuries, including wrongful death to any one person and subject to the same limit for each person, in the amount of not less than Five Hundred Thousand (\$500,000) Dollars on the account of any one occurrence.
 - (iv) Property Damage Liability Insurance shall be in an amount of not less than One Hundred Thousand (\$100,000) Dollars per occurrence. General Liability shall be extended to provide "Broad Form Property Damage Liability" and in an amount of not less the One Million (\$1,000,000) Dollars aggregate for damage on account of all occurrences.
 - (v) Any combination of underlying Comprehensive General/Automobile Liability coverage with Umbrella/Excess Liability coverage which provides no less than One Million (\$1,000,000) Dollars Single Limit Bodily Injury & Property Damage Liability Insurance for the Contractor will also be acceptable.

Construction Bid Package

- (vi) The owner may adjust the liability limits to coincide with local government procurement policies and practice within the limits of state and local law.
- E. Builders Risk Insurance. Each Contractor shall maintain insurance to protect himself and the Owner, jointly, from loss incurred by fire, lightning, extended coverage hazards, vandalism, theft, explosion and malicious mischief in the full amount of the Contract and such insurance shall cover all labor and materials connected with the work, including materials delivered to the site but not yet installed.
- F. Installation Floater Insurance. When a contractor is involved solely in the installation of materials and not in the construction of a building, an Installation Floater is required in lieu of a Builder's Risk Policy with the same general conditions applying as set forth in paragraph E.
- G. The Policies as listed above shall all contain the following special provisions:
 - (i) "The Company agrees that thirty (30) days prior to cancellation or reduction of the insurance afforded by this policy with respect to the Contract involved, written notice will be mailed to the owner."
 - (ii) The maintaining of such insurance as outlined herein shall in no way constitute a waiver of legal liability for damage to any adjoining buildings or their contents or the work and property of others on the site beyond the limits of insurance thus maintained. The Contractor shall hold the Owner free and harmless from any injury and damage resulting from the negligent or faulty performance of the Contract by the Contractor or by any Subcontractors.
 - (iii) Each Contractor shall hold the Owner harmless from all payments for patents, either as royalty or otherwise, in the use of materials, methods, appliances, etc., that he may be in any way involved in or connected with any part of his work or the work of his Subcontractors.
 - (iv) Prior to commencement of any work under Contract, the Contractor shall furnish one (1) copy of Declaration of Warranty as evidence of coverage.

ARTICLE 6 - SAFETY

- A. The Contractor will be responsible for initiating, maintaining, and supervising all safety precautions and programs in connection with the work and will take all necessary precautions for the safety of, and will provide the necessary protection to prevent damage, injury, or loss to all employees on the work and other persons who may be affected thereby, all the work and all materials or equipment to be incorporated therein, whether in storage on or off the site, and other property at the site or adjacent thereto, including trees, shrubs, lawns, walks, pavements, roadways, structures, and utilities not designated for removal, relocation, or replacement in the course of construction.
- B. The Contractor will erect and maintain, as required by the conditions and progress of the work, all necessary safeguards for safety protection and will notify owners of adjacent utilities when prosecution of the work may affect them.
- C. The Contractor shall comply with the safety standards provisions of applicable laws, building and construction codes and the "Manual of Accident Prevention in Construction" published by the Associated General Contractors of America, the requirements of the Occupational Safety and Health Act of 1970 (Public Law 91-596), and the requirements of Title 29 of the Code of Federal Regulations, Section 1518 as published in the "Federal Register", Volume 36, No. 75, Saturday,

Construction Bid Package

April 17, 1971. The Contractor shall also comply with Chapter 4101:9-2 of the Ohio Revised Code prohibiting the Employment of Minors in Occupations Hazardous or Detrimental to their health.

- D. The Contractor shall maintain at their office or other well known place at the job site, all articles necessary for giving first aid to the injured, and shall make standing arrangements for the immediate removal to a hospital or a doctor's care of persons (including employees) who may be injured at the job site. In no case shall employees be permitted to work at a job site before the employer has made a standing arrangement for removal of injured persons to a hospital or a doctor's care.

ARTICLE 7 - PERMITS

The Owner is responsible for obtaining and paying for the following permits: State of Ohio Building Permit. The Contractor shall give all notices and comply with all laws, ordinances, rules, and regulations bearing on the conduct of the work as drawn and specified. If the Contractor observes that the Contract Documents are at variance therewith, promptly notify the Owner in writing.

ARTICLE 8 - SUPERVISION

- A. The Contractor will supervise and direct the work. He will be solely responsible for the means, methods, techniques, sequences, and procedures of construction. The Contractor will employ and maintain on the work a qualified supervisor or superintendent who shall have been designated in writing by the Contractor as the Contractor's representative at the site. The Supervisory shall have full authority to act on behalf of the Contractor and communications given to the supervisor shall be as binding as if given to the Contractor. The supervisor shall be present and on the site at all times as required to perform adequate supervision and coordination of the work.
- B. The Owner and its representatives will at all times have access to the work. In addition, authorized representatives and agents of any participating federal or state agency shall be permitted to inspect all work, materials, payrolls, records of personnel, invoices of materials, and other relevant data and records. The Contractor will provide proper facilities for such access and observation of the work and also for any inspection or testing thereof.
- C. The Contractor shall submit a proposed program of operation, showing clearly how the proposed work will be conducted and to bring about the completion of the work within the time limit specified. This program shall outline the proposed sequence, progress and the dates when the work will be sufficiently advanced to permit the installation of the work under other contracts, and the estimated progress payments due under the Contract. The work under this contract shall be so scheduled that as structures are completed, they can be placed into useful operation with a minimum of delay. The program shall be subject to the approval of the Owner.

ARTICLE 9 - CLAIMS AGAINST CONTRACTOR

The Contractor shall indemnify and save the Owner or the Owner's agents harmless from all claims growing out of the lawful demands of Subcontractor's laborers, workmen, mechanics, materialmen, and furnishers of machinery and parts thereof, equipment, tools, and all supplies, incurred in the furtherance of the performance of the work. The Contractor shall, at the Owner's request, furnish satisfactory evidence that all obligations of the nature designated above have been paid, discharged, or waived. If the Contractor fails to do so the Owner may, after having notified the Contractor, either pay unpaid bills or withhold from the Contractor's unpaid compensation a sum of money deemed reasonably sufficient to pay any and all such lawful claims until satisfactory evidence is furnished that all liabilities have been fully discharged whereupon payment to the Contractor shall be resumed, in accordance with the terms of the Contract

Construction Bid Package

Documents, but in no event shall the provisions of this sentence be construed to impose any obligations upon the Owner to either the Contractor, his Surety, or any third party. In paying any unpaid bills of the Contractor, any payment so made by the Owner shall be considered as a payment made under the Contract Documents by the Owner to the Contractor and the Owner shall not be liable to the Contractor for any such payments in good faith.

ARTICLE 10 - SUBCONTRACTING

- A. Neither the Contractor nor the Owner shall sell, transfer, assign, or otherwise dispose of the Contract or any portion thereof, or of his right, title, or interest therein, or his obligations thereunder.
- B. The Contractor shall not sublet, sell, transfer or assign any portion of the contract without written consent of the Owner or his/her designated agent. When such consent is given, the Contractor will be permitted to sublet a portion thereof, but shall perform with his/her own organization, work amounting to no less than fifty percent of the total contract cost, except that any item designated in the contract before computing the amount of work required to be performed by the Contractor with his/her own organization. No subcontract, or transfer of contract, shall in any way release the Contractor of his/her liability under the contract and bonds.
- C. The Contractor shall not award work to Subcontractor(s) without prior written approval of the Owner, after verification by the Ohio Development Services Agency of the subcontractor's current eligibility status, and after submission of all certifications as required in Item 17 of INSTRUCTIONS TO BIDDERS. The Contractor shall be fully responsible to the Owner for the acts and omissions of the Subcontractor(s), and of persons either directly or indirectly employed by them, as he is for the acts and omissions of persons directly employed by him.

ARTICLE 11 - CHANGE OF WORK

- A. The Owner reserves the right to make, at any time during the project, such increases or decreases in quantities and such alternations in details of work as may be deemed necessary or desirable. Such increases or decreases and alterations shall not invalidate the contract nor release the surety, and the Contractor agrees to perform the work as altered, the same as if it had been a part of the original contract.
- B. Authorized alterations in plans or quantities of work involving work not covered by unit prices in the proposal shall be paid for as stipulated in the change order authorizing such work.

ARTICLE 12 - TIME

- A. The date of beginning and the time for completion of the work are essential conditions of the Contract Documents and the work embraced shall be commenced on a date specified in the Notice to Proceed.
- B. The Contractor will proceed with the work at such rate of progress to ensure full completion within the Contract Time. It is expressly understood and agreed, by and between the Contractor and the Owner, that the Contract Time for the completion of the work described herein is a reasonable time, taking into consideration the average climatic and economic conditions and other factors prevailing in the locality of the work.
- C. The Contract Time to fully complete the project shall be 90* consecutive calendar days following the date of commencement of work to be specified in a written "Notice to Proceed".
* Unless otherwise specified for in Contract.

Construction Bid Package

- D. If the Contractor shall fail to complete the work within the Contract Time, or extension of time granted by the Owner, the Contractor will pay to the Owner for liquidated damages of \$200.00 for each calendar day that the Contractor shall be in default after the time stipulated in the Contract Documents.

ARTICLE 13 - COMPLETION OF WORK

- A. The Contractor shall guarantee all materials and equipment furnished and work performed for a period of one year from the date of Substantial Completion. The Contractor warrants and guarantees for a period of one year from the date of Substantial Completion of the improvement that it is free from all defects due to faulty materials or workmanship, and the Contractor shall promptly make corrections as may be necessary by reason of such defects. The Owner will give notice of observed defects with reasonable promptness. In the event that the Contractor should fail to make repairs, adjustments, or other work which may be made necessary by such defects, the Owner may do so and charge the Contractor the cost thereby incurred. The Bonds shall remain in full force and effect through the guarantee period.
- B. When the work, including that performed by Subcontractors, is completed, the site shall be cleared of all rubbish and debris caused by the construction. All sheds or other temporary structures, surplus materials, and equipment shall be removed and the project left in a neat and presentable condition.

ARTICLE 14 - TERMINATION

After ten (10) days from delivery of a Written Notice to the Contractor, the Owner may, without cause and without prejudice to any other right or remedy elect to terminate the Contract. In such case the Contractor shall be paid for all work executed and any expense sustained, plus reasonable profit, unless such termination was due to the act or conduct of the Contractor.

ARTICLE 15 - PAYMENT

Payment to the Contractor shall be made by the Owner as follows: Thirty (30) days after submission of final invoice, or pending receipt of drawdown from the Ohio Development Services Agency. The Owner's Representative shall certify on the pay request that he approved the completed work prior to the Owner making payment. Upon receipt of an approved progress schedule from the Contractor, the Owner shall submit a drawdown request to the Ohio Development Services Agency for CDBG funds to pay the Contractor. A turnaround time of 20-30 days is expected before said funds are forwarded to the Owner.

It is important that the progress schedule be based on achievable goals, and that the Contractor make every effort to meet target dates. The Owner may hold the proceeds of a CDBG drawdown for only a short period. If the funds from the drawdown are not expended during the prescribed period, those funds must be returned and a new drawdown requested. This causes delay in making payments to contractors.

Construction Bid Package

SUPPLEMENTAL GENERAL CONDITIONS

1. ENUMERATION OF PLANS, SPECIFICATIONS AND ADDENDA

Following are the Plans, Specifications, and Addenda which form a part of this contract, as set forth in Article I of the General Contract Conditions, "Contract and Contract Documents".

Drawings	Number	Date
Refer to construction drawings	A2.0	See drawing

Specifications	Page
Refer to construction drawings	A2.0

Addenda	Number	Date
Not Applicable		

2. STATED ALLOWANCES

The Contractor shall include the following cash allowances in his proposal:

Not Applicable

3. SPECIAL HAZARDS

The Contractor's and his Subcontractor's Public Liability and Property Damage Insurance shall provide adequate protection against the following special hazards:

Not Applicable

4. CONTRACTOR'S AND SUBCONTRACTOR'S PUBLIC LIABILITY, VEHICLE LIABILITY, AND PROPERTY DAMAGE INSURANCE

As required under Article 5 of General Contract Conditions, the Contractor's Public Liability Insurance and Vehicle Liability Insurance shall be in an amount not less than \$250,000 for injuries, including accidental death, to any one person, and subject to the same limit for each person in an amount not less than \$500,000 on account of one accident, and Contractor's Property Damage Insurance in an amount not less than \$100,000.

The Contractor shall either (1) require each of his subcontractors to procure and to maintain during the life of his subcontract, Subcontractor's Public Liability and Property Damage of the type and in the same amounts as specified in the preceding paragraph, or (2) insure the activities of his subcontractors in his own policy.

5. PHOTOGRAPHS OF PROJECT

The Contractor will furnish photographs in the number, type, and stage as enumerated below:

Not Applicable

6. SCHEDULE OF FEDERAL OCCUPATIONAL CLASSIFICATIONS AND DAVIS-BACON MINIMUM HOURLY WAGE RATES

Construction Bid Package

Given on pages: H-15

7. **BUILDER'S RISK INSURANCE**

The Contractor will not maintain Builder's Risk Insurance (fire and extended coverage) on a 100 percent completed value basis on the insurable portions of the project for the benefit of the Owner, the Contractor, and all subcontractors, as their interests may appear.

PROPOSAL FORMS

SECTION D

Construction Bid Package

FORM OF PROPOSAL

City of Fostoria, Ohio

**City of Fostoria ADA Compliant Sidewalk Ramp Program
S Countyline Street from Findlay Street to Culbertson Lane**

Date _____ Bidder _____

The undersigned proposes to perform all work required and to provide and furnish all labor, materials, tools, equipment, and transportation necessary for the Village of Bloomville, Ohio Sidewalk Replacement program, Bloomville, Ohio in accordance with the plans and specifications prepared by IBI Group, Columbus, OH, for the sum of money specified below.

The undersigned agrees that if within thirty (30) days from the day named for delivering the proposal to the Owner, notice that this proposal will be accepted by the Owner shall be mailed to him, he will within ten (10) days thereafter deliver to the Owner, where directed, a contract properly executed in duplicate on the forms supplied by the Owner.

Bidder hereby agrees to commence work under this contract on or before a date to be specified in written "Notice to Proceed" of the Owner and to fully complete the project within 90 consecutive calendar days thereafter as stipulated in the specifications. Bidder further agrees to pay as liquidated damages, the sum of \$200.00 for each consecutive calendar day thereafter as hereinafter provided in Article 8 of the General Conditions.

The undersigned has received the following Addendum numbers: _____ and acknowledges the additions to, deductions from or changes in the original specifications.

BASE BID: City of Fostoria ADA Compliant Sidewalk Ramp Program

Item 1 BASE BID – GENERAL CONSTRUCTION:

The proposed contract sum for all work included in Proposed ADA Compliant Sidewalk Ramps excluding alternatives and depicted on the Drawings is:

_____ Dollars
(Show amount in both words and figures)

(\$ _____)

Bidder understands that the Owner reserves the right to reject any or all bids and to waive any informalities in the bidding.

The Bidder agrees that this bid shall be good and may not be withdrawn for a period of

Construction Bid Package

30 calendar days after the scheduled closing time for receiving bids.

Upon receipt of written notice of the acceptance of this bid, Bidder will execute the formal contract attached within 10 days and deliver the Bonds as required by Article 2 of the General Conditions.

The bid bond attached is to become the property of the Owner in the event the contract and bond are not executed within the time above set forth, as liquidated damages for the delay and additional expense to the Owner caused thereby.

Item 2 PROPOSED TIME OF COMPLETION:

The undersigned proposes that all work shall be completed within 90 calendar days after award of contract, not considering delays due to strikes or circumstances unavoidable to the Contractor.

Name of Bidder

Signature of Authorized Officer and Title

Address

City

Phone

Fax

Email

(SEAL – if bid is by a corporation)

Construction Bid Package

BID BOND

Any singular reference to Bidder, Surety, Owner or other party shall be considered plural where applicable

BIDDER (Name and Address):

SURETY (Name and Address of Principal Place of Business):

OWNER (Name and Address):

BID Bid Due Date: _____

Description: **City of Fostoria ADA Compliant Sidewalk Ramp Program**

BOND Bond Number: _____

Date: _____

Penal Sum _____ \$ _____
(Words) (Figures)

Surety and Bidder, intending to be legally bond hereby, subject to the terms set forth below, do each cause this Bid Bond to be duly executed by an authorized officer, agent, or representative.

BIDDER

SURETY

Bidder's Name and Corporate Seal

Surety's Name and Corporate Seal

By: _____
Signature

By: _____
Signature (Attach Power of Attorney)

Print Name

Print Name

Title

Title

Attest: _____
Signature

Attest: _____
Signature

Title _____

Title _____

Note: Addresses are to be used for giving any required notice. Provide execution by any additional parties, such as joint venture, if necessary.

Construction Bid Package

1. Bidder and Surety, jointly and severally, bind themselves, their heirs, executors, administrators, successors, and assigns to pay to Owner upon default of Bidder the penal sum set forth on the face of this Bond. Payment of the penal sum is the extent of Bidder's and Surety's liability. Recovery of such penal sum under the terms of this Bond shall be Owner's sole and exclusive remedy upon default of Bidder.
2. Default of Bidder shall occur upon the failure of the Bidder to deliver within the time required by the Bidding Documents (or any extension thereof agreed to in writing by the Owner) the executed Agreement required by the Bidding Documents and any performance and payment bonds required by the Bidding Documents.
3. This obligation shall be null and void if:
 - 3.1 Owner accepts Bidder's and Bidder delivers within the time required by the Bidding Documents (or any extension thereof agreed to in writing by Owner) the executed Agreement required by the Bidding Documents and any performance and payment bonds required by the Bidding Documents, or
 - 3.2 All Bids are rejected by Owner, or
 - 3.3 Owner fails to issue a Notice of Award to Bidder within the time specified in the Bidding Documents (or any extension thereof agreed to in writing by Bidder and, if applicable, consented to by Surety when required by Paragraph 5 hereof).
4. Payment under this Bond will be due and payable upon default and with 30 calendar days after receipt by Bidder and Surety of written notice of default from Owner, which notice will be given with reasonable promptness identifying this Bond and the Project and including a statement of the amount due.
5. Surety waives notice of any and all defenses based on or arising out of any time extension to issue Notice of Award agreed to in writing by Owner and Bidder, provided that the total time for issuing Notice of Award including extensions shall not in the aggregate exceed 120 days from the Bid due date without Surety's written consent.
6. No suit or action shall be commenced under this Bond prior to 30 to 30 calendar days after the notice of default required in Paragraph 4 above is received by Bidder and Surety and in no case later than one year after the Bid due date.
7. Any suit or action under this Bond shall be commenced only in a court of competent jurisdiction located in the state in which the Project is located.
8. Notices required hereunder shall be in writing and sent to Bidder and Surety at their respective addresses shown on the face of this Bond. Such notices may be sent by personal delivery, commercial courier, or the US registered of Certified Mail, return receipt requested, postage prepaid, and shall be deemed to be effective upon the receipt by the party concerned.
9. Surety shall cause to be attached to this Bond a current and effective Power of Attorney evidencing the authority of the officer, agent, or representative who executed this Bond on behalf of Surety to execute, seal and deliver such Bond and bind the Surety thereby.
10. This Bond is intended to conform to all applicable statutory requirements. Any applicable requirement of any applicable statute that has been omitted from this Bond shall be deemed to be included herein as if set forth at length. If any provision of this Bond conflicts with any applicable statute, then the provision of said statute shall govern and the remainder of the Bond that is not in conflict therewith shall continue in full force and effect.
11. The term "Bid" as used herein includes a bid, offer, or proposal as applicable.

Construction Bid Package

NONCOLLUSION AFFIDAVIT

State of _____

BID Identification: **City of Fostoria ADA Compliant Sidewalk Ramp Program**

, being first duly sworn, deposes and says that he is _____
(sole owner, a partner, president, secretary, etc.) of _____,

the party making the foregoing BID; that such BID is not made in the interest of or on behalf of any undisclosed person, partnership, company, association, organization, or corporation; that such BID is genuine and not collusive or sham; that said BIDDER has not directly or indirectly induced or solicited any other BIDDER to put in a false or sham BID, and has not directly or indirectly colluded, conspired, connived, or agreed with any BIDDER or anyone else to put in a sham BID, or that anyone shall refrain from bidding; that said BIDDER has not in any manner, directly or indirectly, sought by agreement, communications or conference with anyone to fix the BID price of said BIDDER or of any other BIDDER, or to fix any overhead, profit, or cost element of such BID price, or of that of any other BIDDER, or to secure any advantage against the OWNER awarding the contract or anyone interested in the proposed contract; that all statements contained in such BID are true; and, further, that said BIDDER has not, directly or indirectly, submitted his BID price or any breakdown thereof, or the contents thereof, or paid and will not pay any fee in connection therewith, to any corporation, partnership, company, association, organization, BID depository, or to any member or agent thereof, or to any other individual except to such person or persons as have a partnership or other financial interest with said BIDDER in his general business.

Signed:

..... Affiant

Subscribed and sworn to before me this _____ day of _____, 20_____.

Seal

..... Notary Public

My Commission Expires: _____

Construction Bid Package

BONDING AND INSURANCE REQUIREMENTS

A state or local unit of government receiving a grant from the Federal government which requires contracting for construction of facility improvement shall follow its own requirements relating to bid guarantees, performance bonds, and payment bonds, except for contracts or subcontracts exceeding \$100,000. For contracts or subcontracts exceeding \$100,000, the Federal agency may accept the bonding policy and requirements of the grantee provided the Federal agency has made a determination that the Government's interest is adequately protected. If such a determination has not been made, the minimum requirements shall be as follows:

- a. **A bid (penal) bond from each bidder equivalent to ten percent of the bid price.** The "bid bond" shall consist of a firm commitment such as a bid penal bond issued by a surety licensed to do business in the State of Ohio certified check, cashier's check or a letter of credit as assurance that the bidder will, upon acceptance of the bid, execute such contractual documents as may be required within the time specified.

- b. **A performance bond on the part of the contractor for 100 percent of the contract price.** A "performance bond" is one executed in connection with a contract to secure fulfillment of all the contractor's obligations under such contract.

- c. **A payment bond on the part of the contractor for 100 percent of the contract price.** A "payment bond" is one executed in connection with a contract to assure payment as required by law of all persons supplying labor and material in the execution of the work provided for in the contract.

AGREEMENT FORMS

SECTION E

Construction Bid Package

Construction Bid Package

CONTRACT

THIS AGREEMENT made this _____ day of _____, 20__, by and between _____ hereinafter called the "Contractor" and the _____, hereinafter called the "Owner".

WITNESSETH, that the Contractor and the Owner for the considerations stated herein mutually agree as follows:

ARTICLE 1. Statement of Work.

The Contractor shall furnish all supervision, technical personnel, labor, materials, machinery, tools, equipment and services, including utility and transportation services, and perform and complete all work required for the construction of the improvements embraced in the project; namely, **City of Fostoria ADA Compliant Sidewalk Ramp Program** all in strict accordance with the Contract Documents including all addenda thereto, and in these Contract documents preparation, referred to as the "Quality Control Inspector/Project Manager".

ARTICLE 2. The Contract Price.

The Owner will pay the Contractor for the total quantities of work performed at the unit prices stipulated in the Bid for the respective items of work completed for the sum not to exceed _____(Dollars) subject to additions and deductions as provided hereof.

ARTICLE 3. Contract.

The executed contract documents shall consist of the following:

- a. This Agreement
- b. Addenda
- c. Invitation for Bids
- d. Instructions to Bidders
- e. Signed copy of Bid
- f. General Conditions, Parts I and II
- g. Special Conditions
- h. Technical Specifications
- i. Drawings (as listed in the Schedule of Drawings)

This Agreement, together with other documents enumerated in this ARTICLE 3, which said other documents are as fully a part of the Contract as if hereto attached or herein repeated, forms the Contract between the parties hereto. In the event that any provision in any component part of this Contract conflicts with any provision of any other component part, the provision of the component part first enumerated in this ARTICLE 3 shall govern, except as otherwise specifically stated.

(1) Choose term most applicable:
_____ a corporation organized and existing under the laws of the State of _____;
_____ a partnership consisting of _____;
_____ an individual trading as _____.

(2) Supply principal items of Contract such as Grading, Paving, Water Mains, Sewers, etc.

Construction Bid Package

IN WITNESS WHEREOF, the parties hereto have caused this **AGREEMENT** to be executed in three (3) original copies on the day and year first above written.

CONTRACTOR SIGNATURE:	
TYPED/PRINTED NAME:	
TITLE:	

OWNER SIGNATURE:	
TYPED/PRINTED NAME:	
TITLE:	

Certifications:

I, _____, certify that I am the _____ of the corporation named as Contractor herein; that _____ who signed this Agreement on behalf of the Contractor, was then _____ of said corporation; that said Agreement was duly signed for an in behalf of said corporation by authority of its governing body, and is within the scope of its corporate powers.

_____ Corporate

_____ SEAL

PERFORMANCE BOND AND PAYMENT BOND

Following the Form of Agreement, attach the approved form of the statutory surety bond or bonds to insure the Performance of the Contract and Payment of labor and materials. In addition to the corporation signatures of the surety company(ies) on the bond(s), each bond should be countersigned by the surety company's attorney-in-fact, authorized to act within the state in which the Project is situated.

Construction Bid Package

NOTICE OF AWARD

To: _____

PROJECT Description: **City of Fostoria ADA Compliant Sidewalk Ramp Program**

The OWNER has considered the BID submitted by you on _____, 2022 (BID Date) for the above described WORK in response to its Advertisement for BIDS and Information for BIDDERS.

You are hereby notified that your BID has been accepted for items in the amount of \$_____.

You are required by the Information for BIDDERS to execute the Agreement and furnish the required Contractor's Contract BOND, if applicable, and Certificates of Insurance within 10 calendar days from the date of this notice to you.

If you fail to execute said Agreement and to furnish said BOND within 10 days from the date of this notice, said OWNER will be entitled to consider all your rights arising out of the OWNER's acceptance of your BID as abandoned and as a forfeiture of your BID guaranty subject to the liability as set forth in Section 153.54 of the Ohio Revised Code. The OWNER will be entitled to such other rights as may be granted by law.

You are required to return an acknowledged copy of this NOTICE OF AWARD to the OWNER.

Dated this ____ day of _____, 20____.

Owner
By: _____
Name: _____
Title: _____

ACCEPTANCE OF NOTICE

Receipt of the above NOTICE OF AWARD is hereby acknowledged on this __ day of _____, 2022.

By: _____

Name and Title: _____

cc: CONTRACTOR'S Surety
Surety's Agent

Construction Bid Package

NOTICE TO PROCEED

To: _____

Date: _____

PROJECT Description: **City of Fostoria ADA Compliant Sidewalk Ramp Program**

You are hereby notified to commence WORK in accordance with the Agreement dated _____, 2022, on or before _____, 2022, and you are to complete the WORK within 90 consecutive calendar days thereafter. The date of completion of all WORK is therefore _____.

Owner

By: _____

Name: _____

Title: _____

ACCEPTANCE OF NOTICE

Receipt of the above NOTICE TO PROCEED is hereby acknowledged on this ___ day of _____, 2022.

Contractor: _____

By: _____

Name: _____

Title: _____

Construction Bid Package

**AFFIDAVIT OF CONTRACTOR OR SUPPLIER OF NON-DELINQUENCY OF
PERSONAL PROPERTY TAXES**

O.R.C. 5919.042

STATE OF OHIO:

SS:

TO:

The undersigned, being first duly sworn, having been awarded a contract by you for

hereby states that we are not charged at the time the bid was submitted with any delinquent personal property taxes on the general tax list of personal property of any county in which you as a taxing district have territory and that we were not charged with delinquent personal property taxes on any such tax list.

In consideration of the award of the above contract, the above statement is incorporated in said contract as a covenant of the undersigned.

Contractor/Supplier Representative Signature

Sworn to before me and subscribed in my presence this ____ day of _____, 2022.

Notary Public Signature

Construction Bid Package

CHANGE ORDER

Change Order No. _____

Date: _____

Agreement Date: _____

NAME OF PROJECT: **City of Fostoria ADA Compliant Sidewalk Ramp Program**

OWNER: _____

CONTRACTOR: _____

The following changes are hereby made to the CONTRACT DOCUMENTS:

Justification:

Change to CONTRACT PRICE

Original CONTRACT PRICE: \$ _____

Current CONTRACT PRICE adjusted by previous CHANGE ORDER: \$ _____

The CONTRACT PRICE due to this CHANGE ORDER will be (increased) (decreased) by:
\$ _____.

The new CONTRACT PRICE, including this CHANGE ORDER will be \$ _____.

Change to CONTRACT TIME:

The CONTRACT TIME will be (increased) (decreased) by _____ calendar days.

The date for completion of all WORK will be _____ (Date)

Requested by: _____

Recommended by: _____

Accepted by: _____

OLGS Approval (where applicable) _____

Construction Bid Package

NON-DISCRIMINATION STATEMENT

ORC § 153.59

Revised 04/22/2009

Pursuant to Ohio Revised Code section 153.59, every contract for or on behalf of the state, or any township, county, or municipal corporation of the state, for the construction, alteration, or repair of any public building or public work in the state shall contain provisions by which the contractor agrees to both of the following:

THEREFORE, _____, hereby agrees to both of the following:

(A) That, in the hiring of employees for the performance of work under the contract or any subcontract, no contractor, subcontractor, or any person acting on a contractor's or subcontractor's behalf, by reason of race, creed, sex, disability or military status as defined in section 4112.01 of the Revised Code, or color, shall discriminate against any citizen of the state in the employment of labor or workers who is qualified and available to perform the work to which the employment relates; and

(B) That no contractor, subcontractor, or any person on a contractor's or subcontractor's behalf, in any manner, shall discriminate against or intimidate any employee hired for the performance of work under the contract on account of race, creed, sex, disability or military status as defined in section 4112.01 of the Revised Code, or color.

IN AGREEMENT HEREOF:

CONTRACTOR:

By: _____

Its: _____

Date: _____

CERTIFICATE OF OWNER'S ATTORNEY

I, the undersigned, _____, the duly authorized and acting legal representative of _____, do hereby certify as follows:

I have examined the attached contract(s) and surety bonds and the manner of execution thereof, and I am of the opinion that each of the aforesaid agreements has been duly executed by the proper parties thereto acting through their duly authorized representatives; that said representatives have full power and authority to execute said agreements on behalf of the respective parties named thereon; and that the foregoing agreements constitute valid and legally binding obligations upon the parties executing the same in accordance with terms, conditions and provisions thereof.

Date: _____

CERTIFICATE OF OWNER'S FINANCIAL OFFICER

ATTEST:

I, _____, Auditor, hereby certify that the money to meet this contract has been lawfully appropriated for the purpose of the contract and is in the treasury of _____, Ohio, or is in the process of collection to the credit of the appropriate fund free from prior encumbrance.

Auditor

Date _____

SEAL:

FEDERAL & STATE REQUIREMENTS

SECTION F

Construction Bid Package

CONFLICT OF INTEREST

Interest of Local Public Officials

No member of the governing body of the locality and no other officer, employee, agent or public official of such locality, who exercises any functions or responsibilities in connection with the planning and carrying out of the program, shall have any personal financial interest, direct or indirect, in this contract; and the Business/Agent shall take appropriate steps to assure compliance.

Interest of Contractor and Employees

The Contractor covenants that he presently has no interest and shall not acquire interest, direct or indirect, in the study area or any parcels therein or any other interest which would conflict in any manner or degree with the performance of his services hereunder. The Contractor further covenants that in the performance of this Contract no person having any such interest shall be employed.

Records and Audits

The Contractor shall maintain accounts and records, including personnel, property and financial records, adequate to identify and account for all costs pertaining to the Contract and such other records as may be deemed necessary by the County to assure proper accounting for all project funds. These records will be made available for audit purposes to the County or any authorized representative, and will be retained for **three** years after the expiration of this Contract unless permission to destroy them is granted by the County.

Federal or State Officials Not to Benefit

No members of or delegate to the Congress of the United States of America, and no resident U.S. Commissioner, nor any officer or employee of the State of Ohio subject to Ohio Ethics Law (ORC Sec. 102.03(A)) will be admitted to any share or part hereof or to any benefit to arise therefrom.

SPECIAL CONDITIONS PERTAINING TO HAZARDS SAFETY STANDARDS AND ACCIDENT PREVENTION

A. Lead-Based Paint Hazards

(Applicable to contracts for construction or rehabilitation of residential structures)

The construction or rehabilitation of residential structures is subject to the HUD Lead-Based Paint regulations, 24 CFR Part 35. The Contractor and Subcontractors shall comply with the provisions for the elimination of lead-based paint hazards under sub-part B of said regulations. The Owner will be responsible for the inspections and certifications required under Section 35.14(f) thereof.

B. Use of Explosives

When the use of explosives is necessary for the prosecution of the work, the Contractor shall observe all local, state and Federal laws in purchasing and handling explosives. The Contractor shall take all necessary precaution to protect completed work, neighboring property, water lines, or other underground structures. Where there is danger to structures or property from blasting, the charges shall be reduced and the material shall be covered with suitable timber, steel or rope mats.

The Contractor shall notify all owners of public utility property of intention to use explosives at least eight hours before blasting is done, close to such property. Any supervision or direction of use of explosives by the Engineer, does not in any way reduce the responsibility of the Contractor

Construction Bid Package

or his Surety for damages that may be caused by such use.

C. Danger Signals and Safety Devices

The Contractor shall make all necessary precautions to guard against damages to property and injury to persons. He shall put up and maintain in good condition, sufficient red or warning lights at night, suitable barricades and other devices necessary to protect the public. In case the Contractor fails or neglects to take such precautions, the Owner may have such lights and barricades installed and charge the cost of this work to the Contractor. such action by the Owner does not relieve the Contractor of any liability incurred under these specifications or contract.

SPECIAL EQUAL OPPORTUNITY PROVISIONS

A. Activities and Contracts Not Subject to Executive Order 11246, as Amended

(Applicable to Federally assisted construction contracts and related subcontracts \$10,000 and under)

During the performance of this contract, the Contractor agrees as follows:

1. The Contractor shall not discriminate against any employee or applicant for employment because of race, color, religion, sex, or national origin. The Contractor shall take affirmative action to ensure that applicants for employment are employed, and that employees are treated during employment, without regard to their race, color, religion, sex, or national origin. Such action shall include, but not be limited to, the following: employment, upgrading, demotion, or transfer; recruitment or recruitment advertising; layoff or termination; rates of pay or other forms of compensation; and selection for training, including apprenticeship.
2. **The Contractor shall post in conspicuous places, available to employees and applicants for employment, notices to be provided by the Owner setting forth the provisions of this non-discrimination clause.** The Contractor shall state that all qualified applicants will receive consideration for employment without regard to race, color, religion, sex, or national origin.
3. Contractors shall incorporate foregoing requirements in all subcontracts.

B. Executive Order 11246 (Contracts/Subcontracts above \$10,000)

1. Section 202 Equal Opportunity Clause

During the performance of this contract, the Contractor agrees as follows:

- (1) The contractor will not discriminate against any employee or applicant for employment because of race, color, religion, sex, or national origin. The contractor will take affirmative action to ensure that applicants are employed, and that employees are treated during employment, without regard to their race, color, religion, sex, or national origin. Such action shall include, but not be limited to the following: employment, upgrading, demotion, or transfer; recruitment, or recruitment advertising; layoff or termination, rates of pay or other forms of compensation; and selection for training, including apprenticeship. The contractor agrees to post in conspicuous places, available to employees and applicants for employment, notices to be provided by the Owner setting forth the provisions of this non discrimination clause.

Construction Bid Package

- (2) The contractor will, in all solicitations or advertisements for employees placed by or on behalf of the contractor, state that all qualified applicants will receive consideration without regard to race, color, religion, sex, or national origin.
 - (3) The contractor will send to each labor union or representative of workers with which he has a collective bargaining agreement or other contractor or understanding, a notice to be provided by the Owner advising the said labor union or workers' representatives of the contractor's commitment under this section, and shall post copies of the notice in conspicuous places available to employees and applicants for employment.
 - (4) The contractor will comply with all provisions of Executive Order 11246 of September 24, 1965, and of the rules, regulations, and relevant orders of the Secretary of Labor.
 - (5) The contractor will furnish all information and reports required by Executive Order 11246 of September 24, 1965, and by rules, regulations and orders of the Secretary of Labor, or pursuant thereto, and will permit access to his/her books, records, and accounts by the Ohio Development Services Agency's Office of Local Government Services (OLGS), the U.S. Department of Labor and the Secretary of Labor for purposes of investigation to ascertain compliance with such rules, regulations, and others.
 - (6) In the event of the contractor's non-compliance with the non-discrimination clauses of this contract or with any of the said rules, regulations, or orders, this contract may be canceled, terminated, or suspended in whole or in part and the contractor may be declared ineligible for further Government contracts in accordance with procedures authorized in Executive Order 11246 of September 24, 1965, or by rules, regulations or order of the Secretary of Labor, or as otherwise provided by law.
 - (7) The contractor will include the provisions of the sentence immediately preceding paragraph (1) and the provisions of paragraphs (1) through (7) in every subcontract or purchase order unless exempted by rules, regulations, or orders of the Secretary of Labor issued pursuant to Section 204 of Executive Order 11246 of September 24, 1965, so that such provisions will be binding upon each subcontractor or vendor. The contractor will take such action with respect to any subcontract or purchase order as the Department may direct as a means of enforcing such provisions, including sanctions for non-compliance. Provided, however, that in the event a contractor becomes involved in, or is threatened with, litigation with a subcontractor or vendor as a result of such direction by the Department, the contractor may request the United States to enter into such litigation to protect the interest of the United States.
2. Notice of Requirement for Affirmative Action to Ensure Equal Employment Opportunity (Executive Order 11246). (Applicable to contracts/subcontracts exceeding \$10,000)
- (1) The Offerer's or Bidder's attention is called to the "Equal Opportunity Clause" and the "Standard Federal Equal Employment Opportunity Construction Contract Specifications" set forth herein.

Construction Bid Package

- (2) The goals and timetables for minority and female participation, expressed in percentage terms for the Contractor's aggregate workforce in each trade on all construction work in the covered area, are as follows:

Goals for Minority	Goals for Female
Participation.....	Participation
10.0%	6.9%

These goals are applicable to all the Contractor's construction work (whether or not it is Federal or federally assisted) performed in the covered areas. The Contractor's compliance with the Executive Order and the regulations in 41 CFR Part 60-4 shall be based on its implementation of the Equal Opportunity Clause, specific affirmative action obligations required by the specifications set forth in 41 CFR 60-4.3(a), and its efforts to meet the goals established for the geographical area where the contract resulting from this solicitation is to be performed. The hours of minority and female employment and training must be substantially uniform throughout the length of the contract, and in each trade, and the contractor shall make a good faith effort to employ minorities and women evenly on each of its projects. The transfer of minority or female employees or trainees from Contractor to Contractor or from project to project for the sole purpose of meeting the Contractor's goals shall be a violation of the contract, the Executive Order and the regulations in 41 CFR Part 60-4. Compliance with the goals will be measured against the total work hours performed.

- (3) The Contractor shall provide written notification to the Manager of the Office of Local Government Services, Ohio Development Services Agency, P.O. Box 1001, Columbus, OH 43266-0101 within 10 working days of award of any construction subcontract in excess of \$10,000 at any tier for construction work under the contract resulting from this solicitation. The notification shall list the name, address, and telephone number of the subcontractor; employer identification number; estimated dollar amount of the subcontract; estimated starting and completion dates of the subcontract; and the geographical area in which the contract is to be performed.
- (4) As used in this Notice, and in the contract resulting from this solicitation, the "covered area" Seneca County Ohio.

3. Standard Federal Equal Employment Opportunity Construction Contract Specifications (Executive Order 11246)

- (1) As used in these specifications:
- a. "Covered area" means the geographical area described in the solicitation from which this contract resulted;
 - b. "Director" means Director, Office of Federal Contract Compliance Programs, United States Department of Labor, or any person to whom the Director delegates authority;
 - c. "Employer Identification Number" means the Federal Social Security number used on the Employer's Quarterly Federal Tax Return, U.S. Treasury Department Form 941;

Construction Bid Package

d. "Minority" includes:

- (i) Black: all persons having origins in any of the Black African racial groups not of Hispanic origin;
 - (ii) Hispanic: all persons of Mexican, Puerto Rican, Cuban, Central or South American or other Spanish Culture or origin, regardless of race;
 - (iii) Asian and Pacific Islander: all persons having origins in any of the original peoples of the Far East, Southeast Asia, the Indian Subcontinent, or the Pacific Islands; and
 - (iv) American Indian or Alaskan Native: all persons having origins in any of the original peoples of North America and maintaining identifiable tribal affiliations through membership and participation or community identification.
- (2) Whenever the Contractor, or any Subcontractor at any tier, subcontracts a portion of the work involving any construction trade, it shall physically include in each subcontract in excess of \$10,000 the provisions of these specifications and the Notice which contains the applicable goals for minority and female participation and which is set forth in the solicitations from which this contract resulted.
- (3) If the Contractor is participating (pursuant to 41 CFR 60-4.5) in a Hometown Plan approved by the U.S. Department of Labor in the covered area either individually or through an association, its affirmative action obligations on all work in the Plan area (including goals and timetables) shall be in accordance with that Plan for those trades which have unions participating in the Plan. Contractors must be able to demonstrate their participation in and compliance with the provisions of any such Hometown Plan. Each Contractor or Subcontractor participating in an approved Plan is individually required to comply with its obligations under the EEO clause, and to make a good faith effort to achieve each goal under the Plan in each trade in which it has employees. The overall good faith performance by other Contractors or Subcontractors toward a goal in an approved Plan does not excuse any covered Contractor's or Subcontractor's failure to take good faith efforts to achieve the Plan goals and timetables.
- (4) The Contractor shall implement the specific affirmative action standards provided in paragraphs 7a through 7p of these specifications. The goals set forth in the solicitation from which this contract resulted are expressed as percentages of the total hours of employment and training of minority and female utilization the Contractor should reasonable be able to achieve in each construction trade in which it has employees in the covered area. The Contractor is expected to make substantially uniform progress toward its goals in each craft during the period specified.
- (5) Neither the provisions of any collective bargaining agreement, nor the failure by a union with whom the Contractor has a collective bargaining agreement, to refer either minorities or women shall excuse the Contractor's obligations under these specifications, Executive Order 11246, or the regulations promulgated pursuant thereto.
- (6) In order for the nonworking training hours of apprentices and trainees to be counted in meeting the goals, such apprentices and trainees must be employed by the Contractor during the training period, and the Contractor must have made a commitment to employ the apprentices and trainees at the completion of their

Construction Bid Package

training, subject to the availability of employment opportunities. Trainees must be trained pursuant to the training programs approved by the U.S. Department of Labor.

- (7) The Contractor shall take specific affirmative actions to ensure equal employment opportunity. The evaluation of the Contractor's compliance with these specifications shall be based upon its effort to achieve maximum results from its actions. The Contractor shall document these efforts fully, and shall implement affirmative action steps at least as extensive as the following:
- a. Ensure and maintain a working environment free of harassment, intimidation, and coercion at all sites, and in facilities at which the Contractor's employees are assigned to work. The Contractor, where possible, will assign two or more women to each construction project. The Contractor shall specifically ensure that all foremen, superintendents, and other on-site supervisory personnel are aware of and carry out the Contractor's obligation to maintain such a working environment, with specific attention to minority or female individuals working at such sites or in such facilities.
 - b. Establish and maintain a current list of minority and female recruitment sources, provide written notification to minority and female recruitment sources and to community organizations when the Contractor or its unions have employment opportunities available, and maintain a record of the organizations' responses.
 - c. Maintain a current file of the names, addresses and telephone numbers of each minority and female off-the-street applicant and minority or female referral from a union, a recruitment source of community organization and of what action was taken with respect to each such individual. If such individual was sent to the union hiring hall for referral and was not referred back to the Contractor by the union or, if referred, not employed by the Contractor, this shall be documented in the file with the reason therefore, along with whatever additional actions the Contractor may have taken.
 - d. Provide immediate written notification to the Director when the union or unions with which the Contractor has a collective bargaining agreement has not referred to the Contractor a minority person or woman sent by the Contractor, or when the Contractor has other information that the union referral process has impeded the Contractor's efforts to meet its obligations.
 - e. Develop on-the-job training opportunities and/or participate in training programs for the area which expressly include minorities and women, including upgrading programs and apprenticeship and trainee programs relevant to the Contractor's employment needs, especially those programs funded or approved by the Department of Labor. The Contractor shall provide notice of these programs to the sources compiled under 7b.
 - f. Disseminate the Contractor's EEO policy by providing notice of the policy to unions and training programs and requesting their cooperation in assisting the Contractor in meeting its EEO obligations; by including it in any policy manual and collective bargaining agreement; by publicizing it in the company newspaper, annual report, etc.; by specific review of the policy with all management personnel and with all minority & female employees at least once a year; and by posting the company EEO policy on bulletin boards accessible to all employees at each location where construction work is

Construction Bid Package

performed.

- g. Review, at least annually, the company's EEO policy and affirmative action obligations under these specifications with all employees having any responsibility for hiring, assignment, layoff, termination or other employment decisions including specific review of these items with on site supervisory personnel such as Superintendents, General Foremen, etc., prior to the initiation of construction work at any job site. A written record shall be made and maintained identifying the time and place of these meetings, persons attending, subject matter discussed, and disposition of the subject matter.
- h. Disseminate the Contractor's EEO policy externally by including it in any advertising in the news media, specifically including minority and female news media, and providing written notification to and discussing the Contractor's EEO policy with other Contractors and Subcontractors with whom the Contractor does or anticipates doing business.
- i. Direct its recruitment efforts, both oral and written, to minority female and community organizations, to schools with minority and female students and to minority and female recruitment and training organizations serving the Contractor's recruitment area and employment needs. Not later than one month prior to the date for the acceptance of applications for apprenticeship or other training by any recruitment source, the Contractor shall send written notification to organizations such as the above, describing the openings, screening procedures, and tests to be used in the selection process.
- j. Encourage present minority and female employees to recruit other minority persons and women and, where reasonable, provide after school, summer and vacation employment to minority and female youth both on the site and in other areas of a Contractor's work force.
- k. Validate all tests and other selection requirements where there is an obligation to do so under 41 CFR Part 60-3.
- l. Conduct, at least annually, an inventory and evaluation at least of all minority and female personnel for promotional opportunities and encourage these employees to seek or to prepare for, through appropriate training, etc. such opportunities.
- m. Ensure that seniority practices, job classifications, work assignments and other personnel practices, do not have a discriminatory effect by continually monitoring all personnel and employment related activities to ensure that the EEO policy and the Contractor's obligations under these specifications are being carried out.
- n. Ensure that all facilities and company activities are nonsegregated except that separate or single-user toilet and necessary changing facilities shall be provided to assure privacy between the sexes.
- o. Document and maintain a record of all solicitations of offers for subcontracts from minority and female construction contractors and suppliers, including circulation of solicitations to minority and female contractor associations and other business associations.
- p. Conduct a review, at least annually, of all supervisors' adherence to and

Construction Bid Package

performance under the Contractor's EEO policies and affirmative action obligations.

- q. Covered construction contractors performing contracts in geographical areas where they do not have a federal or federally assisted construction contract shall apply at the minority and female goals established for the geographical area where the contract is being performed. Goals are published periodically in the Federal Register in notice form and such notices may be obtained from any Office of Federal Contract Compliance Programs office or from Federal procurement contracting offices.
- (8) Contractors are encouraged to participate in voluntary associations which assist in fulfilling one or more of their affirmative action obligations (7a through 7q). The efforts of a contractor association, joint contractor-union, contractor-community, or other similar group of which the contractor is a member and participant, may be asserted as fulfilling any one or more of its obligations under 7a through 7q of these Specifications provided that the contractor actively participates in the group, makes every effort to assure that the group has a positive impact on the employment of minorities and women in the industry, ensures that the concrete benefits of the program are reflected in the Contractor's minority and female workforce participation, makes a good faith effort to meet its individual goals and timetables, and can provide access to documentation which demonstrates the effectiveness of actions taken on behalf of the Contractor. The obligation shall not be a defense for the Contractor's non-compliance.
- (9) A single goal for minorities and a separate single goal for women have been established. The Contractor, however, is required to provide equal employment opportunity and to take affirmative action for all minority groups, both male and female, and all women, both minority and non-minority. Consequently, the Contractor may be in violation of the Executive Order if a particular group is employed in a substantially desperate manner (for example, even though the Contractor has achieved its goals for women generally, the Contractor may be in violation of the Executive Order if a specific minority group of women is underutilized).
- (10) The Contractor shall not use the goals and timetables or affirmative action standards to discriminate against any person because of race, color, religion, sex, or national origin.
- (11) The Contractor shall not enter into any Subcontract with any person or firm debarred from Government contracts pursuant to Executive Order 11246.
- (12) The Contractor shall carry out such sanctions and penalties for violation of these specifications and of the Equal Opportunity Clause, including suspension, termination and cancellation of existing subcontracts as may be imposed or ordered pursuant to Executive Order 11246, as amended, and its implementing regulations, by the Office of Federal Contract Compliance Programs. Any Contractor who fails to carry out such sanctions and penalties shall be in violation of these specifications and Executive Order 11246, as amended.
- (13) The Contractor, in fulfilling its obligations under these specifications, shall implement specific affirmative action steps, at least as extensive as those standards prescribed in paragraph 7 of these specifications, so as to achieve maximum results from its efforts to ensure equal employment opportunity. If the Contractor fails to comply with the requirements of the Executive Order the

Construction Bid Package

implementing regulations, or these specifications, the Director shall proceed in accordance with 41 CFR 60-4.8.

- (14) The Contractor shall designate a responsible official to monitor all employment related activity to ensure that the company EEO policy is being carried out, to submit reports relating to the provisions hereof as may be required by OLGs and to keep records. Records shall at least include for each employee the name, address, telephone numbers, construction trade, union affiliation if any, employee identification number when assigned, social security number, race, sex, status (e.g., mechanic, apprentice trainee, helper, or laborer), dates of changes in status, hours worked per week in the indicated trade, rate of pay, and locations at which the work was performed. Records shall be maintained in an easily understandable and retrievable form; however, to the degree that existing records satisfy this requirement, contractors shall not be required to maintain separate records.
- (15) Nothing herein provided shall be construed as a limitation upon the application of other laws which establish different standards of compliance or upon the application of requirements for the hiring of local or other area residents (e.g., those under the Public Works Employment Act of 1977 and the Community Development Block Grant Program).

C. Certification of Nonsegregated Facilities (Over \$10,000)

By the submission of this bid, the bidder, offerer applicant or subcontractor certifies that he/she does not maintain or provide for his/her employees any segregated facility at any of his/her establishments, and that he/she does not permit employees to perform their services at any location, under his/her control, where segregated facilities are maintained. The bidder, offerer, applicant or subcontractor agrees that a breach of this certification is a violation of the Equal Opportunity Clause of this contract. As used in this certification, the term "segregated facilities" means any waiting rooms, work areas, rest rooms and wash rooms, restaurants and other eating areas, time clocks, locker rooms, and other storage or dressing areas, ** transportation and housing facilities provided for employees which are segregated by explicit directive or are in fact segregated on the basis of race, color, religion, or national origin, because of habit, local custom, or otherwise. He/She further agrees that (except where he/she has obtained identical certifications from proposed subcontractors for specific time periods) he/she will obtain identical certification from proposed subcontractors prior to the award of subcontracts exceeding \$10,000 which are not exempt from the provisions of the Equal Opportunity clause; that he/she will retain such certifications in his/her files and that he/she will forward the following notice to such proposed subcontractors (except where proposed subcontractors have submitted identical certification for specific time periods).

**Parking lots, drinking fountains, recreation or entertainment areas.

D. Civil Rights Act of 1964

Under Title VI of the Civil Rights Act of 1964, no person shall, on the grounds of race, color, or national origin, be excluded from participation in, be denied the benefits of, or be subjected to discrimination under any program or activity receiving Federal financial assistance.

E. Section 109 of the Housing and Community Development Act of 1974.

No person in the United States shall on the ground of race, color, national origin, or sex be excluded from participation in, be denied the benefits of, or be subjected to discrimination under any program or activity funded in whole or in part with funds made available under this title.

F. **"Section 3" Compliance in the Provision of Training, Employment and Business Opportunities**

- a. The work to be performed under this contract is on a project assisted under a program providing direct Federal financial assistance from the Department of Housing and Urban Development and is subject to the requirements of Section 3 of the Housing and Urban Development Act of 1968, as amended, 12 U.S.C. 1701u. [Section 3 requires that to the greatest extent feasible opportunities for training and employment be given lower income residents of the project area and contracts for work in connection with the project be awarded to business concerns which are located in, or owned in substantial part by persons residing in the area of the project.]
- b. The parties to this contract will comply with the provisions of said Section 3 and the regulations issued pursuant thereto by the Secretary of Housing and Urban Development set forth in 24 CFR 135, and all applicable rules and orders of the Department issued thereunder prior to the execution of this contract. The parties to this contract certify and agree that they are under no contractual or other disability which would prevent them from complying with these requirements.
- c. The contractor will send to each labor organization or representative of workers with which he has a collective bargaining agreement or other contract or understanding, if any, a notice advising the said labor organization or workers' representative of his commitments under this Section 3 clause and shall post copies of the notice in conspicuous places available to employees and applicants for employment or training.
- d. The contractor will include this Section 3 clause in every subcontract for work in connection with the project and will, at the direction of the applicant for recipient of Federal financial assistance, take appropriate action pursuant to the subcontract upon a finding that the subcontractor is in violation of regulations issued by the Secretary of Housing and Urban Development, 24 CFR Part 135. The contractor will not subcontract with any subcontractor where it has notice or knowledge that the latter has been found in violation of regulations under 24 CFR Part 135 and will not let any subcontract unless the subcontractor has first provided it with a preliminary statement of ability to comply with the requirements of these regulations.
- e. Compliance with the provisions of Section 3, the regulations set forth in 24 CFR Part 135, and all applicable rules and orders of the Department issued hereunder prior to the execution of the contract, shall be a condition of the federal assistance provided to the project, binding upon the applicant or recipient for such assistance, its successors and assigns. Failure to fulfill these requirements shall subject the applicant or recipient, its contractors and subcontractors, its successors and assigns to those sanctions specified by the grant or loan agreement or contract through which federal assistance is provided, and to such sanctions as are specified by 24 CFR Part 135.

Construction Bid Package

CONTRACTOR

Section 3 Plan Format

_____ agrees to implement the following specific affirmative action steps directed at increasing the utilization of lower income residents and businesses with the City/County of Seneca.

- A. To ascertain from the locality's CDBG program official the exact boundaries of the Section 3 covered project area and where advantageous, seek the assistance of local officials in preparing and implementing the affirmative action plan.
- B. To attempt to recruit from within the City/County the necessary number of lower income residents through: local advertising media, signs placed at the proposed site for the project, and community organizations and public or private institutions operating within or serving the project area such as Service Employment and Redevelopment (SER), Opportunities Industrialization Center (OIC), Urban League, Concentrated Employment Program, Hometown Plan, or the U.S. Employment Service.
- C. To maintain a list of all lower income area residents who have applied either on their own or on referral from any source, and to employ such persons, if otherwise eligible and if a vacancy exists.
- *D. To insert this Section 3 plan in all bid documents, and to require all bidders on subcontracts to submit a Section 3 affirmative action plan including utilization goals and the specific steps planned to accomplish these goals.
- *E. To insure that subcontracts which are typically let on a negotiated rather than a bid basis in areas other than Section 3 covered project areas, are also let on a negotiated basis, whenever feasible, when let in Section 3 covered project area.
- *F. To formally contact unions, subcontractors and trade associations to secure their cooperation for this program.
- G. To insure that all appropriate project area business concerns are notified of pending subcontractual opportunities.
- H. To maintain records, including copies of correspondence, memoranda, etc., which document that all of the above affirmative action steps have been taken.
- I. To appoint or recruit an executive official of the company or agency as Equal Opportunity Officer to coordinate the implementation of this Section 3 plan.
- J. To list on Table A, information related to proposed subcontracts.
- K. To list on Table B, all projected workforce needs for all phases of this project by occupation, trade, skill level and number of positions.
- * Loans, grant, contracts and subsidies for less than \$10,000 will be exempt.

Construction Bid Package

As _____ officers _____ and _____ representatives _____ of _____ (Complete Name of Contractor),

We the undersigned have read and fully agree to this Affirmative Action Plan, and become party to the full implementation of this program.

Signature	
Title	
Date	
Signature	
Title	
Date	

Construction Bid Package

Table A

Proposed Subcontracts Breakdown

For the period covering _____ 2022 through _____ 2022.

(Duration of the CDBG-Assisted Project)

Column 1	Column 2	Column 3	Column 4	Column 5
Type of Contract (Business of Profession)	Total Number of Contracts	Total Approximate Dollar Amount	Estimated No. Contracts to Project Area Businesses*	Estimated \$ Amount to Project Area Businesses*

*The Project Area is coextensive with the City/Village/County of Seneca boundaries.

Company	
Project Name	
Project Number	
EEO Officer (Signature)	

Construction Bid Package

**Table B
Estimated Project Workforce Breakdown**

Column 1	Column 2	Column 3	Column 4	Column 5
Job Category	Total Estimate Positions	No. Positions Currently Occupied by Permanent Employees	No. Positions Not Currently Occupied	No. Positions to be Filled with LIPAR*
Officers/Supervisors				
Professionals				
Technicians				
Housing Sales/ Rental/Mgmt				
Office Clerical				
Service				
Others				
Trade:				
Journeyman				
Helpers				
Apprentices				
Max. No. Trainees				
Others				
Trade:				
Journeyman				
Helpers				
Apprentices				
Max. No. Trainees				
Others				
Trade:				
Journeyman				
Helpers				
Apprentices				
Max. No. Trainees				
Others				

*Lower income project area residents (LIPAR) are individuals residing within the City of Fostoria whose family income does not exceed _____% of the median income in the MSA.

Company	
---------	--

Construction Bid Package

**OHIO DEVELOPMENT SERVICES AGENCY
OFFICE OF LOCAL GOVERNMENT SERVICES**

CERTIFICATION OF BIDDER REGARDING EQUAL EMPLOYMENT OPPORTUNITY

Name of Prime Contractor	
Project Number	

INSTRUCTIONS

This certification is required pursuant to Executive Order 11246 (30 CFR 12319-25). The implementing rules and regulations provide that any bidder or prospective contractor, or any of their proposed subcontractors, shall state as an initial part of the bid or negotiations of the contract whether it has participated in any previous contract or subcontract subject to the equal opportunity clause; and, if so, whether it has filed all compliance reports due under applicable instructions.

Where the certification indicates that the bidder has not filed a compliance report due under applicable instructions, such bidder shall be required to submit a compliance report within seven calendar days after bid opening. No contract shall be awarded unless such report is submitted.

CONTRACTOR'S CERTIFICATION		
NAME AND ADDRESS OF BIDDER (Include Zip Code)		
1.	Bidder has participated in a previous contract or subcontract subject to the Equal Opportunity Clause	Yes No
2.	Compliance reports were required to be filed in connection with such contract or subcontract.	Yes No
3.	Bidder has filed all compliance reports due under applicable instructions, including SF-100.	Yes No
4.	Have you ever been or are you being considered for sanction due to violation of Executive Order 11246, as amended?	Yes No
NAME AND TITLE OF SIGNER (Please type)		
SIGNATURE		DATE

Modeled after form HUD-12

Construction Bid Package

**OHIO DEVELOPMENT SERVICES AGENCY
OFFICE OF LOCAL GOVERNMENT SERVICES**

CERTIFICATION OF SUBCONTRACTOR REGARDING EQUAL EMPLOYMENT OPPORTUNITY

Name of Prime Contractor	
Project Number	

INSTRUCTIONS

This certification is required pursuant to Executive Order 11246 (30 CFR 12319-25). The implementing rules and regulations provide that any bidder or prospective contractor, or any of their proposed subcontractors, shall state as an initial part of the bid or negotiations of the contract whether it has participated in any previous contract or subcontract subject to the equal opportunity clause; and, if so, whether it has filed all compliance reports due under applicable instructions.

Where the certification indicates that the subcontractor has not filed a compliance report due under applicable instructions, such subcontractor shall be required to submit a compliance report before the owner approves the subcontract or permits work to begin under the subcontract.

SUBCONTRACTOR'S CERTIFICATION		
NAME AND ADDRESS OF SUBCONTRACTOR (Include Zip Code)		
1.	Bidder has participated in a previous contract or subcontract subject to the Equal Opportunity Clause	Yes No
2.	Compliance reports were required to be filed in connection with such contract or subcontract.	Yes No
3.	Bidder has filed all compliance reports due under applicable instructions, including SF-100.	Yes No
4.	Have you ever been or are you being considered for sanction due to violation of Executive Order 11246, as amended?	Yes No
NAME AND TITLE OF SIGNER (Please type)		
SIGNATURE		DATE

Modeled after form HUD-12

Construction Bid Package

**CERTIFICATION OF BIDDER REGARDING
SECTION 3 AND SEGREGATED FACILITIES**

Name of Prime Contractor	
Project Name	
Project Number	

The undersigned hereby certifies that:

- (a) Section 3 provisions are included in this Contract;
- (b) A written Section 3 plan was prepared and submitted as part of the bid proceedings (if bid equals or exceeds \$10,000); and
- (c) No segregated facilities will be maintained.

Name and Title of Signer (Print or Type)	
Signature	
Date	

Construction Bid Package

**CERTIFICATION OF SUBCONTRACTOR REGARDING
SECTION 3 AND SEGREGATED FACILITIES**

Name of Subcontractor	
Project Name	
Project Number	

The undersigned hereby certifies that:

- (a) Section 3 provisions are included in this Contract;
- (b) A written Section 3 plan was prepared and submitted as part of the bid proceedings (if bid equals or exceeds \$10,000); and
- (c) No segregated facilities will be maintained as required by Title VI of the Civil Rights Act of 1964.

Name and Title of Signer (Print or Type)	
Signature	
Date	

CERTIFICATION OF COMPLIANCE WITH AIR AND WATER ACTS

(Applicable to Federally assisted construction contracts and related subcontracts exceeding \$100,000)

Compliance with Air and Water Acts

During the performance of this contract, the contractor and all subcontractors shall comply with the requirements of the Clean Air Act, as amended, 42 USC 1857 et seq., the Federal Water Pollution Control Act, as amended, 33 USC 1251 et seq., and the regulations of the Environmental Protection Agency with respect thereto, at 40 CFR Part 15, as amended.

In addition to the foregoing requirements, all nonexempt contractors and subcontractors shall furnish to the owner, the following:

- (1) A stipulation by the Contractor or subcontractors, that any facility to be utilized in the performance of any nonexempt contract or subcontract, is not listed on the List of Violating Facilities issued by the Environmental Protection Agency (EPA) pursuant to 40 CFR 15.20.
- (2) Agreement by the contractor to comply with all the requirements of Section 114 of the Clean Air Act, as amended, (42 USC 1857c-8) and Section 308 of the Federal Water Pollution Control Act, as amended, (33 USC 1318) relating to inspection, monitoring, entry, reports and information, as well as all other requirements specified in said Section 114 and Section 308, and all regulations and guidelines issued thereunder.
- (3) A stipulation that as a condition for the award of the contract, prompt notice will be given of any notification received from the Director, Office of Federal Activities, EPA, indicating that a facility utilized, or to be utilized for the contract, is under consideration to be listed on the EPA List of Violating Facilities.
- (4) Agreement by the Contractor that he will include, or cause to be included, the criteria and requirements in paragraph (1) through (4) of this section in every nonexempt subcontract and requiring that the Contractor will take such action as the Government may direct as a means of enforcing such provisions.

Construction Bid Package

**ARCHITECT'S CERTIFICATION
COMPLIANCE WITH MINIMUM STANDARDS FOR
ACCESSIBILITY BY THE PHYSICALLY HANDICAPPED**

Grantee Number	
Project Name	

Pursuant to the requirements of the Architectural Barriers Act of 1968, 42 USC 4151, and the regulations issued subsequent thereto, the undersigned certifies that the design of the above-mentioned project is in conformance with the minimum standards contained in the American Standard Specifications for Making Buildings and Facilities Accessible To and Usable By, the Physically Handicapped, Number A-117.1R-1971 (as modified by 41 CFR 101-19.603).

Architect for the Project:	
Address:	
Signature:	
Typed Name:	
Date:	
Name of CEO:	
Signature:	
Date:	

**FEDERAL LABOR STANDARDS PROVISIONS
AND WAGE RATES**

SECTION G

"General Decision Number: OH20220001 04/08/2022

Superseded General Decision Number: OH20210001

State: Ohio

Construction Types: Heavy and Highway

Counties: Ohio Statewide.

Heavy and Highway Construction Projects

Note: Contracts subject to the Davis-Bacon Act are generally required to pay at least the applicable minimum wage rate required under Executive Order 14026 or Executive Order 13658. Please note that these Executive Orders apply to covered contracts entered into by the federal government that are subject to the Davis-Bacon Act itself, but do not apply to contracts subject only to the Davis-Bacon Related Acts, including those set forth at 29 CFR 5.1(a)(2)-(60).

<p>If the contract is entered into on or after January 30, 2022, or the contract is renewed or extended (e.g., an option is exercised) on or after January 30, 2022:</p>	<p>. Executive Order 14026 generally applies to the contract.</p> <p>. The contractor must pay all covered workers at least \$15.00 per hour (or the applicable wage rate listed on this wage determination, if it is higher) for all hours spent performing on the contract in 2022.</p>
<p>If the contract was awarded on or between January 1, 2015 and January 29, 2022, and the contract is not renewed or extended on or after January 30, 2022:</p>	<p>. Executive Order 13658 generally applies to the contract.</p> <p>. The contractor must pay all covered workers at least \$11.25 per hour (or the applicable wage rate listed on this wage determination, if it is higher) for all hours spent performing on that contract in 2022.</p>

The applicable Executive Order minimum wage rate will be adjusted annually. If this contract is covered by one of the Executive Orders and a classification considered necessary for performance of work on the contract does not appear on this wage determination, the contractor must still submit a conformance request.

Additional information on contractor requirements and worker protections under the Executive Orders is available at <https://www.dol.gov/agencies/whd/government-contracts>.

Modification Number	Publication Date
0	01/07/2022
1	01/14/2022
2	01/28/2022

3	02/18/2022
4	02/25/2022
5	03/11/2022
6	04/08/2022

BROH0001-001 06/01/2021

DEFIANCE, FULTON (Excluding Fulton, Amboy & Swan Creek Townships), HENRY (Excluding Monroe, Bartlow, Liberty, Washington, Richfield, Marion, Damascus & Townships & that part of Harrison Township outside corporate limits of city of Napoleon), PAULDING, PUTNAM and WILLIAMS COUNTIES

	Rates	Fringes
Bricklayer, Stonemason.....	\$ 30.40	17.55

BROH0001-004 06/01/2021

	Rates	Fringes
CEMENT MASON/CONCRETE FINISHER...	\$ 30.40	17.55

BROH0003-002 06/01/2021

FULTON (Townships of Amboy, Swan Creek & Fulton), HENRY (Townships of Washington, Damascus, Richfield, Bartlow, Liberty, Harrison, Monroe, & Marion), LUCAS and WOOD (Townships of Perrysburg, Ross, Lake, Troy, Freedom, Montgomery, Webster, Center, Portage, Middleton, Plain, Liberty, Henry, Washington, Weston, Milton, Jackson & Grand Rapids) COUNTIES

	Rates	Fringes
Bricklayer, Stonemason.....	\$ 30.40	17.55

BROH0005-003 06/01/2020

CUYAHOGA, LORAIN & MEDINA (Hinckley, Granger, Brunswick, Liverpool, Montville, York, Homer, Harrisville, Chatham, Litchfield & Spencer Townships and the city of Medina)

	Rates	Fringes
BRICKLAYER		
BRICKLAYERS; CAULKERS;		
CLEANERS; POINTERS; &		
STONEMASONS.....	\$ 36.64	17.13
SANDBLASTERS.....	\$ 36.39	17.13
SEWER BRICKLAYERS & STACK		
BUILDERS.....	\$ 36.64	17.13
SWING SCAFFOLDS.....	\$ 37.14	17.13

BROH0006-005 06/01/2021

CARROLL, COLUMBIANA (Knox, Butler, West & Hanover Townships), STARK & TUSCARAWAS

	Rates	Fringes
Bricklayer, Stonemason.....	\$ 30.40	17.55

BROH0007-002 06/01/2021

LAWRENCE

	Rates	Fringes
Bricklayer, Stonemason.....	\$ 30.40	17.55

BROH0007-005 06/01/2021

PORTAGE & SUMMIT

	Rates	Fringes
BRICKLAYER.....	\$ 30.40	17.55

BROH0007-010 06/01/2017

PORTAGE & SUMMIT

	Rates	Fringes
MASON - STONE.....	\$ 28.65	14.55

BROH0008-001 06/01/2021

COLUMBIANA (Salem, Perry, Fairfield, Center, Elk Run, Middleton, & Unity Townships and the city of New Waterford), MAHONING & TRUMBULL

	Rates	Fringes
BRICKLAYER.....	\$ 30.40	17.55

BROH0009-002 06/01/2021

BELMONT & MONROE COUNTIES and the Townships of Warren & Mt. Pleasant and the Village of Dillonvale in JEFFERSON COUNTY

	Rates	Fringes
Bricklayer, Stonemason.....	\$ 30.40	17.55
Refractory.....	\$ 31.45	19.01

BROH0010-002 06/01/2021

COLUMBIANA (St. Clair, Madison, Wayne, Franklin, Washington, Yellow Creek & Liverpool Townships) & JEFFERSON (Brush Creek & Saline Townships)

	Rates	Fringes
Bricklayer, Stonemason.....	\$ 30.40	17.55

BROH0014-002 06/01/2021

HARRISON & JEFFERSON (Except Mt. Pleasant, Warren, Brush Creek, Saline & Salineville Townships & the Village of Dillonvale)

	Rates	Fringes
--	-------	---------

Bricklayer, Stonemason.....\$ 30.40 17.55

 BROH0016-002 06/01/2021

ASHTABULA, GEAUGA, and LAKE COUNTIES

	Rates	Fringes
Bricklayer, Stonemason.....	\$ 30.40	17.55

BROH0018-002 06/01/2021		

BROWN, BUTLER, CLERMONT, HAMILTON, PREBLE (Gasper, Dixon, Israel, Lanier, Somers & Gratis Townships) & WARREN COUNTIES:

	Rates	Fringes
Bricklayer, Stonemason.....	\$ 30.40	17.55

BROH0022-004 06/01/2021		

CHAMPAIGN, CLARK, CLINTON, DARKE, GREENE, HIGHLAND, LOGAN, MIAMI, MONTGOMERY, PREBLE (Jackson, Monroe, Harrison, Twin, Jefferson & Washington Townships) and SHELBY COUNTIES

	Rates	Fringes
Bricklayer, Stonemason.....	\$ 30.40	17.55

BROH0032-001 06/01/2021		

GALLIA & MEIGS

	Rates	Fringes
Bricklayer, Stonemason.....	\$ 30.40	17.55

BROH0035-002 06/01/2021		

ALLEN, AUGLAIZE, MERCER and VAN WERT COUNTIES

	Rates	Fringes
Bricklayer, Stonemason.....	\$ 30.40	17.55

BROH0039-002 06/01/2021		

ADAMS & SCIOTO

	Rates	Fringes
Bricklayer, Stonemason.....	\$ 30.40	17.55

BROH0040-003 06/01/2021		

ASHLAND, CRAWFORD, HARDIN, HOLMES, MARION, MORROW, RICHLAND, WAYNE and WYANDOT (Except Crawford, Ridge, Richland & Tymochtee Townships) COUNTIES

	Rates	Fringes
--	-------	---------

Bricklayer, Stonemason.....\$ 31.93 22.54

FOOTNOTE: Layout Man and Sawman rate: \$1.00 per hour above journeyman rate.

Free standing stack work ground level to top of stack; Sandblasting and laying of carbon masonry material in swing stage and/or scaffold; Ramming and spading of plastics and gunniting: \$1.50 per hour above journeyman rate.

""Hot"" work: \$2.50 above journeyman rate.

BROH0044-002 06/01/2021

Rates Fringes

Bricklayer, Stonemason
COSHOCOTON, FAIRFIELD,
GUERNSEY, HOCKING, KNOX,
KICKING, MORGAN,
MUSKINGUM, NOBLE (Beaver,
Buffalo, Seneca & Wayne
Townships) & PERRY
COUNTIES:.....\$ 30.40 17.55

BROH0045-002 06/01/2021

FAYETTE, JACKSON, PIKE, ROSS and VINTON COUNTIES

Rates Fringes

Bricklayer, Stonemason.....\$ 30.40 17.66

BROH0046-002 06/01/2021

ERIE, HANCOCK, HURON, OTTAWA, SANDUSKY, SENECA, WOOD (Perry & Bloom Townships) and WYANDOT (Tymochtee, Crawford, Ridge & Richland Townships) COUNTIES & the Islands of Lake Erie north of Sandusky

Rates Fringes

Bricklayer, Stonemason.....\$ 30.40 17.55

FOOTNOTE: Layout Man and Sawman rate: \$1.00 per hour above journeyman rate.

Free standing stack work ground level to top of stack; Sandblasting and laying of carbon masonry material in swing stage and/or scaffold; Ramming and spading of plastics and gunniting: \$1.50 per hour above journeyman rate.

""Hot"" work: \$2.50 above journeyman rate.

BROH0052-001 06/01/2021

ATHENS COUNTY

Rates Fringes

Bricklayer, Stonemason.....\$ 30.40 17.55

BROH0052-003 06/01/2021

NOBLE (Brookfield, Noble, Center, Sharon, Olive, Enoch, Stock, Jackson, Jefferson & Elk Townships) and WASHINGTON COUNTIES

	Rates	Fringes
Bricklayer, Stonemason.....	\$ 30.40	17.55

BROH0055-003 06/01/2021		

DELAWARE, FRANKLIN, MADISON, PICKAWAY and UNION COUNTIES

	Rates	Fringes
Bricklayer, Stonemason.....	\$ 30.40	17.55

CARP0003-004 05/01/2017		

MAHONING & TRUMBULL

	Rates	Fringes
CARPENTER.....	\$ 26.20	17.42

CARP0069-003 05/01/2017		

CARROLL, STARK, TUSCARAWAS & WAYNE

	Rates	Fringes
CARPENTER.....	\$ 25.98	15.98

CARP0069-006 05/01/2017		

COSHOCTON, HOLMES, KNOX & MORROW

	Rates	Fringes
CARPENTER.....	\$ 24.04	15.29

CARP0171-002 05/01/2019		

BELMONT, COLUMBIANA, HARRISON, JEFFERSON & MONROE

	Rates	Fringes
CARPENTER.....	\$ 27.37	20.02

CARP0200-002 05/01/2021		

ADAMS, ATHENS, DELAWARE, FAIRFIELD, FAYETTE, FRANKLIN, GALLIA, GUERNSEY, HIGHLAND, HOCKING, JACKSON, LAWRENCE, LICKING, MADISON, MARION, MEIGS, MORGAN, MUSKINGUM, NOBLE, PERRY, PICKAWAY, PIKE, ROSS, SCIOTO, UNION, VINTON and WASHINGTON COUNTIES

	Rates	Fringes
CARPENTER.....	\$ 30.28	20.08
Diver.....	\$ 39.41	10.40
PILEDRIVERMAN.....	\$ 30.28	20.08

CARP0248-005 07/01/2008		

LUCAS & WOOD

	Rates	Fringes
CARPENTER.....	\$ 27.27	14.58

CARP0248-008 07/01/2008		

	Rates	Fringes
CARPENTER DEFIANCE, FULTON, HANCOCK, HENRY, PAULDING & WILLIAMS COUNTIES.....	\$ 23.71	13.28

CARP0254-002 05/01/2017		

ASHTABULA, CUYAHOGA, GEAUGA & LAKE

	Rates	Fringes
CARPENTER.....	\$ 32.40	16.97

CARP0372-002 05/01/2016		

ALLEN, AUGLAIZE, HARDIN, MERCER, PUTNAM & VAN WERT

	Rates	Fringes
CARPENTER.....	\$ 24.54	18.21

CARP0639-003 05/01/2017		

MEDINA, PORTAGE & SUMMIT

	Rates	Fringes
CARPENTER.....	\$ 30.42	16.99

CARP0735-002 05/01/2019		

ASHLAND, ERIE, HURON, LORAIN & RICHLAND

	Rates	Fringes
CARPENTER.....	\$ 26.30	17.91

CARP1311-001 05/01/2017		

BROWN, BUTLER, CHAMPAIGN, CLARK, CLERMONT, CLINTON, DARKE,
GREENE, HAMILTON, LOGAN, MIAMI, MONTGOMERY, PREBLE, SHELBY &
WARREN

	Rates	Fringes
Carpenter & Piledrivermen.....	\$ 29.34	15.95
Diver.....	\$ 40.58	9.69

CARP1393-002 07/01/2008		

CRAWFORD, DEFIANCE, FULTON, HANCOCK, HENRY, LUCAS, OTTAWA,
PAULDING, SANDUSKY, SENECA, WILLIAMS & WOOD

	Rates	Fringes
--	-------	---------

Piledrivermen & Diver's Tender...\$ 27.30 16.05

DIVERS - \$250.00 per day

 CARP1393-003 07/01/2008

ALLEN, AUGLAIZE, HARDIN, MERCER, PUTNAM, VAN WERT & WYANDOT

Rates Fringes

Piledrivermen & Diver's Tender...\$ 25.15 15.92

DIVERS - \$250.00 per day

 CARP1871-006 05/01/2017

BELMONT, HARRISON, & MONROE

Rates Fringes

Diver, Wet.....\$ 48.11 17.33

Piledrivermen; Diver, Dry.....\$ 32.07 17.33

 CARP1871-008 05/01/2017

ASHLAND, ASHTABULA, CUYAHOGA, ERIE, GEAUGA, HURON, LAKE,
 LORAIN, MEDINA, PORTAGE, RICHLAND & SUMMIT

Rates Fringes

Diver, Wet.....\$ 45.80 18.84

Piledrivermen; Diver, Dry.....\$ 30.53 18.84

 CARP1871-014 05/01/2017

CARROLL, STARK, TUSCARAWAS & WAYNE

Rates Fringes

Diver, Wet.....\$ 38.34 16.95

Piledrivermen; Diver, Dry.....\$ 25.56 16.95

 CARP1871-015 05/01/2017

COSHOCTON, HOLMES, KNOX & MORROW

Rates Fringes

Diver, Wet.....\$ 37.34 16.07

Piledrivermen; Diver, Dry.....\$ 24.89 16.07

 CARP1871-017 05/01/2017

MAHONING & TRUMBULL

Rates Fringes

Diver, Wet.....\$ 40.65 17.62

Piledrivermen; Diver, Dry.....\$ 27.10 17.62

 CARP2235-012 01/01/2014

COLUMBIANA & JEFFERSON

	Rates	Fringes
PILEDRIVERMAN.....	\$ 31.74	16.41

CARP2239-001 07/01/2008		

CRAWFORD, OTTAWA, SANDUSKY, SENECA & WYANDOT

	Rates	Fringes
CARPENTER.....	\$ 23.71	13.28

ELEC0008-002 05/24/2021		

DEFIANCE, FULTON, HANCOCK, HENRY, LUCAS, OTTAWA, PAULDING,
PUTNAM, SANDUSKY, SENECA, WILLIAMS & WOOD

	Rates	Fringes
CABLE SPLICER.....	\$ 38.98	18.96
ELECTRICIAN.....	\$ 43.33	26.61

ELEC0032-003 12/06/2021		

ALLEN, AUGLAIZE, HARDIN, LOGAN, MERCER, SHELBY, VAN WERT &
WYANDOT (Crawford, Jackson, Marseilles, Mifflin, Ridgeland,
Ridge & Salem Townships)

	Rates	Fringes
ELECTRICIAN.....	\$ 33.22	19.73

ELEC0038-002 04/26/2021		

CUYAHOGA, GEAUGA (Bainbridge, Chester & Russell Townships) &
LORAIN (Columbia Township)

	Rates	Fringes
ELECTRICIAN Excluding Sound & Communications Work.....	\$ 40.63	21.74

FOOTNOTES;

- a. 6 Paid Holidays: New Year's Day; Memorial Day; July 4th;
Labor Day; Thanksgiving Day; & Christmas Day
- b. 1 week's paid vacation for 1 year's service; 2 weeks' paid
vacation for 2 or more years' service

ELEC0038-008 04/26/2021		

CUYAHOGA, GEAUGA (Bainbridge, Chester & Russell Townships) &
LORAIN (Columbia Township)

	Rates	Fringes
Sound & Communication Technician		
Communications Technician...	\$ 28.80	12.77
Installer Technician.....	\$ 27.55	12.77

FOOTNOTES;

- a. 6 Paid Holidays: New Year's Day; Memorial Day; July 4th; Labor Day; Thanksgiving Day; & Christmas Day
- b. 1 week's paid vacation for 1 year's service; 2 weeks' paid vacation for 2 or more years' service

ELEC0064-003 11/29/2021

COLUMBIANA (Butler, Fairfield, Perry, Salem & Unity Townships)
 MAHONING (Austintown, Beaver, Berlin, Boardman, Canfield, Ellsworth, Coitsville, Goshen, Green, Jackson, Poland, Springfield & Youngstown Townships), & TRUMBULL (Hubbard & Liberty Townships)

	Rates	Fringes
ELECTRICIAN.....	\$ 36.10	18.17

ELEC0071-001 01/01/2019

ASHLAND, CHAMPAIGN, CLARK, COSHOCTON, CRAWFORD, DELAWARE, FAIRFIELD, FAYETTE, FRANKLIN, GUERNSEY, HIGHLAND, HOCKING, JACKSON (Coal, Jackson, Liberty, Milton, Washington & Wellston Townships), KNOX, LICKING, MADISON, MARION, MONROE, MORGAN, MORROW, MUSKINGUM, NOBLE, PERRY, PICKAWAY, PIKE (Beaver, Benton, Jackson, Mifflin, Pebble, Peepee, Perry & Seal Townships), RICHLAND, ROSS, TUSCARAWAS (Auburn, Bucks, Clay, Jefferson, Oxford, Perry, Salem, Rush, Washington & York Townships), UNION, VINTON (Clinton, Eagle, Elk, Harrison, Jackson, Richland & Swan Townships), and WASHINGTON COUNTIES

	Rates	Fringes
Line Construction		
Equipment Operators.....	\$ 33.62	13.40
Groundmen.....	\$ 24.17	11.32
Linemen & Cable Splicers....	\$ 38.27	14.42

ELEC0071-004 01/01/2019

AUGLAIZE, CLINTON, DARKE, GREENE, LOGAN, MERCER, MIAMI, MONTGOMERY, PREBLE, and SHELBY COUNTIES

	Rates	Fringes
Line Construction		
Equipment Operator.....	\$ 33.62	13.40
Groundman.....	\$ 24.17	11.32
Lineman & Cable Splicers....	\$ 38.27	14.42

ELEC0071-005 12/31/2018

ASHTABULA, CUYAHOGA, GEAUGA, LAKE & LORAIN

	Rates	Fringes
LINE CONSTRUCTION: Equipment Operator		
DOT/Traffic Signal & Highway Lighting Projects...	\$ 32.44	14.10

Municipal Power/Transit Projects.....	\$ 40.10	16.42
LINE CONSTRUCTION: Groundman DOT/Traffic Signal & Highway Lighting Projects...	\$ 25.06	12.26
Municipal Power/Transit Projects.....	\$ 31.19	14.11
LINE CONSTRUCTION: Linemen/Cable Splicer DOT/Traffic Signal & Highway Lighting Projects...	\$ 36.13	15.03
Municipal Power/Transit Projects.....	\$ 44.56	17.58

ELEC0071-008 01/01/2019

COLUMBIANA, MAHONING, and TRUMBULL COUNTIES

	Rates	Fringes
Line Construction		
Equipment Operator.....	\$ 33.62	13.40
Groundman.....	\$ 24.17	11.32
Lineman & Cable Splicers....	\$ 38.27	14.42

ELEC0071-010 01/01/2019

BELMONT, CARROLL, HARRISON, HOLMES, JEFFERSON, MEDINA, PORTAGE,
STARK, SUMMIT, and WAYNE COUNTIES

	Rates	Fringes
Line Construction		
Equipment Operator.....	\$ 33.62	13.40
Groundman.....	\$ 24.17	11.32
Lineman & Cable Splicers....	\$ 38.27	14.42

ELEC0071-013 01/01/2019

BROWN, BUTLER, CLERMONT, HAMILTON, and WARREN COUNTIES

	Rates	Fringes
Line Construction		
Equipment Operator.....	\$ 33.62	13.40
Groundman.....	\$ 24.17	11.32
Lineman & Cable Splicers....	\$ 38.27	14.42

ELEC0071-014 01/01/2019

ADAMS, ATHENS, GALLIA, JACKSON (Bloomfield, Franklin, Hamilton,
Lick, Jefferson, Scioto & Madison Townships), LAWRENCE, MEIGS,
PIKE (Camp Creek, Marion, Newton, Scioto, Sunfish & Union
Townships), SCIOTO & VINTON (Brown, Knox, Madison, Vinton &
Wilkesville Townships)

	Rates	Fringes
Line Construction		
Equipment Operator.....	\$ 33.62	13.40
Groundman.....	\$ 24.17	11.32
Lineman & Cable Splicers....	\$ 38.27	14.42

ELEC0082-002 11/29/2021

CLINTON, DARKE, GREENE, MIAMI, MONTGOMERY, PREBLE & WARREN
(Wayne, Clear Creek & Franklin Townships)

	Rates	Fringes
ELECTRICIAN.....	\$ 33.25	20.84

* ELEC0082-006 11/29/2021

CLINTON, DARKE, GREENE, MIAMI, MONTGOMERY, PREBLE & WARREN
(Wayne, Clear Creek & Franklin Townships)

	Rates	Fringes
Sound & Communication Technician		
Cable Puller.....	\$ 12.98 **	3.89
Installer/Technician.....	\$ 25.95	12.27

* ELEC0129-003 02/28/2022

LORAIN (Except Columbia Township) & MEDINA (Litchfield & Liverpool Townships)

	Rates	Fringes
ELECTRICIAN.....	\$ 37.00	18.23

* ELEC0129-004 02/28/2022

ERIE & HURON (Lyme, Ridgefield, Norwalk, Townsend, Wakeman,
Sherman, Peru, Bronson, Hartland, Clarksfield, Norwich,
Greenfield, Fairfield, Fitchville & New London Townships)

	Rates	Fringes
ELECTRICIAN.....	\$ 37.00	18.23

ELEC0141-003 09/01/2019

BELMONT COUNTY

	Rates	Fringes
CABLE SPLICER.....	\$ 30.63	25.87
ELECTRICIAN.....	\$ 30.38	25.87

ELEC0212-003 11/26/2018

BROWN, CLERMONT & HAMILTON

	Rates	Fringes
Sound & Communication Technician.....	\$ 24.35	10.99

ELEC0212-005 11/29/2021

BROWN, CLERMONT, and HAMILTON COUNTIES

	Rates	Fringes
ELECTRICIAN.....	\$ 37.04	20.64

 ELEC0245-001 01/01/2022

ALLEN, HARDIN, VAN WERT & WYANDOT (Crawford, Jackson, Marseilles, Mifflin, Richland, Ridge & Salem Townships)

	Rates	Fringes
Line Construction		
Equipment Operator.....	\$ 32.37	26.5%+7.25
Groundman Truck Driver.....	\$ 18.60	26.5%+7.25
Lineman.....	\$ 42.52	26.5%+7.25

FOOTNOTE: a. Half day's Paid Holiday: The last 4 hours of the workday prior to Christmas or New Year's Day

 ELEC0245-003 01/01/2022

DEFIANCE, FULTON, HANCOCK, HENRY, HURON, LUCAS, OTTAWA, PAULDING, PUTNAM, SANDUSKY, SENECA, WILLIAMS, and WOOD COUNTIES

	Rates	Fringes
Line Construction		
Cable Splicer.....	\$ 48.90	26.5%+7.25
Groundman/Truck Driver.....	\$ 18.60	26.5%+7.25
Heli-arc Welding.....	\$ 40.76	26.5%+7.25
Lineman.....	\$ 45.52	26.5%+7.25
Operator - Class 1.....	\$ 34.18	26.5%+7.25
Operator - Class 2.....	\$ 28.32	26.5%+7.25
Traffic Signal & Lighting Technician.....	\$ 38.27	26.5%+7.25

FOOTNOTE: a. 6 Observed Holidays: New Year's Day; Memorial Day; Independence Day; Labor Day; Thanksgiving Day; & Christmas Day. Employees who work on a holiday shall be paid at a rate of double their applicable classified straight-time rates for the work performed on such holiday.

 ELEC0245-004 01/01/2022

ERIE COUNTY

	Rates	Fringes
Line Construction		
Cable Splicer.....	\$ 49.14	26.75%+6.75
Cablesplicer.....	\$ 48.90	26.5%+7.25
Groundman/Truck Driver.....	\$ 18.60	26.5%+7.25
Lineman.....	\$ 42.52	26.5%+7.25
Operator - Class 1.....	\$ 34.14	26.5%+7.25
Operator - Class 2.....	\$ 28.32	26.5%+7.25

FOOTNOTE: a. 6 Observed Holidays: New Year's Day; Memorial Day; Independence Day; Labor Day; Thanksgiving Day; & Christmas Day. Employees who work on a holiday shall be paid at a rate of double their applicable classified

straight-time rates for the work performed on such holiday.

 ELEC0246-001 10/29/2018

	Rates	Fringes
ELECTRICIAN.....	\$ 38.00	84%+a

FOOTNOTE: a. 1 1/2 Paid Holidays: The last scheduled workday prior to Christmas & 4 hours on Good Friday.

 ELEC0306-005 05/28/2018

MEDINA (Brunswick, Chatham, Granger, Guilford, Harrisville, Hinckley, Homer, Lafayette, Medina, Montville, Sharon, Spencer, Wadsworth, Westfield & York Townships), PORTAGE (Atwater, Aurora, Brimfield, Deerfield, Franklin, Mantua, Randolph, Ravenna, Rootstown, Shalersville, Streetsboro & Suffield Townships), SUMMIT & WAYNE (Baughman, Canaan, Chester, Chippewa, Congress, Green, Milton, & Wayne Townships)

	Rates	Fringes
CABLE SPLICER.....	\$ 36.87	16.56
ELECTRICIAN.....	\$ 34.54	5%+18.06

 ELEC0317-002 06/01/2021

GALLIA & LAWRENCE

	Rates	Fringes
CABLE SPLICER.....	\$ 32.68	18.13
ELECTRICIAN.....	\$ 35.10	27.47

 ELEC0540-005 12/27/2021

CARROLL (Northern half, including Fox, Harrison, Rose & Washington Townships), COLUMBIANA (Knox Township), HOLMES, MAHONING (Smith Township), STARK, TUSCARAWAS (North of Auburn, Clay, Rush & York Townships), and WAYNE (South of Baughman, Chester, Green & Wayne Townships) COUNTIES

	Rates	Fringes
ELECTRICIAN.....	\$ 35.28	22.63

 ELEC0573-003 11/29/2021

ASHTABULA (Colebrook, Wayne, Williamsfield, Orwell & Windsor Townships), GEAUGA (Auburn, Middlefield, Parkman & Troy Townships), MAHONING (Milton Township), PORTAGE (Charlestown, Edinburg, Freedom, Hiram, Nelson, Palmyra, Paris & Windham Townships), and TRUMBULL (Except Liberty & Hubbard Townships)

	Rates	Fringes
ELECTRICIAN.....	\$ 37.04	20.64

 ELEC0575-001 11/29/2021

ADAMS, FAYETTE, HIGHLAND, HOCKING, JACKSON (Bloomfield, Franklin, Hamilton, Jefferson, Lick, Madison, Scioto, Coal, Jackson, Liberty, Milton & Washington Townships), PICKAWAY (Deer Creek, Perry, Pickaway, Salt Creek & Wayne Townships), PIKE (Beaver, Benton, Jackson, Mifflin, Pebble, PeePee, Perry, Seal, Camp Creek, Newton, Scioto, Sunfish, Union & Marion Townships), ROSS, SCIOTO & VINTON (Clinton, Eagle, Elk, Harrison, Jackson, Richland & Swan Townships)

	Rates	Fringes
ELECTRICIAN.....	\$ 35.00	19.76

ELEC0648-001 08/30/2021		

BUTLER and WARREN COUNTIES (Deerfield, Hamilton, Harlan, Massie, Salem, Turtle Creek, Union & Washington Townships)

	Rates	Fringes
CABLE SPLICER.....	\$ 30.50	18.23
ELECTRICIAN.....	\$ 32.00	20.79

ELEC0673-004 02/01/2020		

ASHTABULA (Excluding Orwell, Colebrook, Williamsfield, Wayne & Windsor Townships), GEAUGA (Burton, Chardon, Claridon, Hambden, Huntsburg, Montville, Munson, Newbury & Thompson Townships) and LAKE COUNTIES

	Rates	Fringes
CABLE SPLICER.....	\$ 33.81	21.47
ELECTRICIAN.....	\$ 33.56	21.47

ELEC0683-002 05/31/2021		

CHAMPAIGN, CLARK, DELAWARE, FAIRFIELD, FRANKLIN, MADISON, PICKAWAY (Circleville, Darby, Harrison, Jackson, Madison, Monroe, Muhlenberg, Scioto, Walnut & Washington Townships), and UNION COUNTIES

	Rates	Fringes
CABLE SPLICER.....	\$ 35.50	21.99
ELECTRICIAN.....	\$ 35.50	21.99

ELEC0688-003 05/31/2021		

ASHLAND, CRAWFORD, HURON (Richmond, New Haven, Ripley & Greenwich Townships), KNOX (Liberty, Clinton, Union, Howard, Monroe, Middleberry, Morris, Wayne, Berlin, Pike, Brown & Jefferson Townships), MARION, MORROW, RICHLAND and WYANDOT (Sycamore, Crane, Eden, Pitt, Antrim & Tymochtee Townships) COUNTIES

	Rates	Fringes
ELECTRICIAN.....	\$ 31.00	21.29

 ELEC0972-002 06/01/2021

ATHENS, MEIGS, MONROE, MORGAN, NOBLE, VINTON (Brown, Knox, Madison, Vinton & Wilkesville Townships), and WASHINGTON COUNITIES

	Rates	Fringes
CABLE SPLICER.....	\$ 37.35	27.81
ELECTRICIAN.....	\$ 34.30	27.62

ELEC1105-001 05/31/2021

COSHOCTON, GUERNSEY, KNOX (Jackson, Clay, Morgan, Miller, Milford, Hilliar, Butler, Harrison, Pleasant & College Townships), LICKING, MUSKINGUM, PERRY, and TUSCARAWAS (Auburn, York, Clay, Jefferson, Rush, Oxford, Washington, Salem, Perry & Bucks Townships) COUNTIES

	Rates	Fringes
ELECTRICIAN.....	\$ 34.25	21.15

ENGI0018-003 05/01/2019

ASHTABULA, CUYAHOGA, ERIE, GEAUGA, LAKE, LORAIN, MEDINA, PORTAGE, and SUMMIT COUNTIES

	Rates	Fringes
POWER EQUIPMENT OPERATOR		
GROUP 1.....	\$ 38.63	15.20
GROUP 2.....	\$ 38.53	15.20
GROUP 3.....	\$ 37.49	15.20
GROUP 4.....	\$ 36.27	15.20
GROUP 5.....	\$ 30.98	15.20
GROUP 6.....	\$ 38.88	15.20
GROUP 7.....	\$ 39.13	15.20

OPERATING ENGINEER CLASSIFICATIONS

GROUP 1 - Air Compressor on Steel Erection; Barrier Moving Machine; Boiler Operator on Compressor or Generator when mounted on a Rig; Cableway; Combination Concrete Mixer & Tower; Concrete Plant (over 4 yd. Capacity); Concrete Pump; Crane (All Types, Including Boom Truck, Cherry Picker); Crane-Compact, Track or Rubber over 4,000 lbs. capacity; Cranes-Self Erecting, Stationary, Track or Truck (All Configurations); Derrick; Dragline; Dredge (Dipper, Clam or Suction); Elevating Grader or Euclid Loader; Floating Equipment (All Types); Gradall; Helicopter Crew (Operator-Hoist or Winch); Hoe (all types); Hoisting Engine on Shaft or Tunnel Work; Hydraulic Gantry (Lifting System); Industrial-Type Tractor; Jet Engine Dryer (D8 or D9) Diesel Tractor; Locomotive (Standard Gauge); Maintenance Operator Class A; Mixer, Paving (Single or Double Drum); Mucking Machine; Multiple Scraper; Piledriving Machine (All Types); Power Shovel; Prentice Loader; Quad 9 (Double Pusher); Rail Tamper (with auto lifting & aligning device); Refrigerating Machine (Freezer Operation); Rotary Drill, on Caisson work; Rough Terrain Fork Lift with Winch/Hoist; Side-Boom;

Slip-Form Paver; Tower Derrick; Tree Shredder; Trench Machine (Over 24" wide); Truck Mounted Concrete Pump; Tug Boat; Tunnel Machine and/or Mining Machine; Wheel Excavator; and Asphalt Plant Engineer (Cleveland District Only).

GROUP 2 - Asphalt Paver; Automatic Subgrader Machine, Self-Propelled (CMI Type); Bobcat Type and/or Skid Steer Loader with Hoe Attachment Greater than 7,000 lbs.; Boring Machine More than 48"; Bulldozer; Endloader; Horizontal Directional Drill (Over 50,000 ft lbs thrust); Hydro Milling Machine; Kolman-type Loader (production type-Dirt); Lead Greaseman; Lighting & Traffic Signal Installation Equipment (includes all groups or classifications); Material Transfer Equipment (Shuttle Buggy) Asphalt; Pettibone-Rail Equipment; Power Grader; Power Scraper; Push Cat; Rotomill (all), Grinders & Planers of All types; Trench Machine (24" wide & under); Vermeer type Concrete Saw; and Maintenance Operators (Portage and Summit Counties Only).

GROUP 3 - A-Frame; Air Compressor on Tunnel Work (low pressure); Asphalt Plant Engineer (Portage and Summit Counties Only); Bobcat-type and/or Skid Steer Loader with or without Attachments; Highway Drills (all types); Locomotive (narrow gauge); Material Hoist/Elevator; Mixer, Concrete (more than one bag capacity); Mixer, one bag capacity (Side Loader); Power Boiler (Over 15 lbs. Pressure) Pump Operator installing & operating Well Points; Pump (4" & over discharge); Roller, Asphalt; Rotovator (lime soil stabilizer); Switch & Tie Tampers (without lifting & aligning device); Utility Operator (Small equipment); Welding Machines; and Railroad Tie Inserter/Remover; Articulating/straight bed end dumps if assigned (minus \$4.00 per hour).

GROUP 4 - Backfiller; Ballast Re-locator; Bars, Joint & Mesh Installing Machine; Batch Plant; Boring Machine Operator (48" or less); Bull Floats; Burlap & Curing Machine; Concrete Plant (capacity 4 yd. & under); Concrete Saw (Multiple); Conveyor (Highway); Crusher; Deckhand; Farm-type Tractor with attachments (highway); Finishing Machine; Fireperson, Floating Equipment (all types); Forklift; Form Trencher; Hydro Hammer expect masonry; Hydro Seeder; Pavement Breaker; Plant Mixer; Post Driver; Post Hole Digger (Power Auger); Power Brush Burner; Power Form Handling Equipment; Road Widening Trencher; Roller (Brick, Grade & Macadam); Self-Propelled Power Spreader; Self-Propelled Power Subgrader; Steam Fireperson; Tractor (Pulling Sheepfoot, Roller or Grader); and Vibratory Compactor with Integral Power.

GROUP 5 - Compressor (Portable, Sewer, Heavy & Highway); Drum Fireperson (Asphalt Plant); Generator; Masonry Fork Lift; Inboard-Outboard Motor Boat Launch; Oil Heater (asphalt plant); Oiler/Helper; Power Driven Heater; Power Sweeper & Scrubber; Pump (under 4" discharge); Signaller; Tire Repairperson; VAC/ALLS; Cranes - Compact, track or rubber under 4,000 pound capacity; fueling and greasing; and Chainmen.

GROUP 6 - Master Mechanic & Boom from 150 to 180.

GROUP 7 - Boom from 180 and over.

 ENGI0018-004 05/01/2019

ADAMS, ALLEN, ASHLAND, ATHENS, AUGLAIZE, BELMONT, BROWN, BUTLER, CARROLL, CHAMPAIGN, CLARK, CLERMONT, CLINTON, COSHOCTON, CRAWFORD, DARKE, DEFIANCE, DELAWARE, FAIRFIELD, FAYETTE, FRANKLIN, FULTON, GALLIA, GREENE, GUERNSEY, HAMILTON, HANCOCK, HARDIN, HARRISON, HENRY, HIGHLAND, HOCKING, HOLMES, HURON, JACKSON, JEFFERSON, KNOX, LAWRENCE, LICKING, LOGAN, LUCAS, MADISON, MARION, MEIGS, MERCER, MIAMI, MONROE, MONTGOMERY, MORGAN, MORROW, MUSKINGUM, NOBLE, OTTAWA, PAULDING, PERRY, PICKAWAY, PIKE, PREBLE, PUTNAM, RICHLAND, ROSS, SANDUSKY, SCIOTO, SENECA, SHELBY, STARK, TUSCARAWAS, UNION, VAN WERT, VINTON, WARREN, WASHINGTON, WAYNE, WILLIAMS, WOOD, and YANDOT COUNTIES

	Rates	Fringes
POWER EQUIPMENT OPERATOR		
GROUP 1.....	\$ 37.14	15.20
GROUP 2.....	\$ 37.02	15.20
GROUP 3.....	\$ 35.98	15.20
GROUP 4.....	\$ 34.80	15.20
GROUP 5.....	\$ 29.34	15.20
GROUP 6.....	\$ 37.39	15.20
GROUP 7.....	\$ 37.64	15.20

OPERATING ENGINEER CLASSIFICATIONS

GROUP 1 - Air Compressor on Steel Erection; Barrier Moving Machine; Boiler Operator on Compressor or Generator when mounted on a Rig; Cableway; Combination Concrete Mixer & Tower; Concrete Plant (over 4 yd. Capacity); Concrete Pump; Crane (All Types, Including Boom Truck, Cherry Picker); Crane-Compact, Track or Rubber over 4,000 lbs. capacity; Cranes-Self Erecting, Stationary, Track or Truck (All Configurations); Derrick; Dragline; Dredge (Dipper, Clam or Suction); Elevating Grader or Euclid Loader; Floating Equipment (All Types); Gradall; Helicopter Crew (Operator-Hoist or Winch); Hoe (all types); Hoisting Engine on Shaft or Tunnel Work; Hydraulic Gantry (Lifting System); Industrial-Type Tractor; Jet Engine Dryer (D8 or D9) Diesel Tractor; Locomotive (Standard Gauge); Maintenance Operator Class A; Mixer, Paving (Single or Double Drum); Mucking Machine; Multiple Scraper; Piledriving Machine (All Types); Power Shovel; Prentice Loader; Quad 9 (Double Pusher); Rail Tamper (with auto lifting & aligning device); Refrigerating Machine (Freezer Operation); Rotary Drill, on Caisson work; Rough Terrain Fork Lift with Winch/Hoist; Side-Boom; Slip-Form Paver; Tower Derrick; Tree Shredder; Trench Machine (Over 24" wide); Truck Mounted Concrete Pump; Tug Boat; Tunnel Machine and/or Mining Machine; and Wheel Excavator.

GROUP 2 - Asphalt Paver; Automatic Subgrader Machine, Self-Propelled (CMI Type); Bobcat Type and/or Skid Steer Loader with Hoe Attachment Greater than 7,000 lbs.; Boring Machine More than 48"; Bulldozer; Endloader; Hydro Milling Machine; Horizontal Directional Drill (over 50,000 ft. lbs. thrust); Kolman-type Loader (production type-Dirt); Lead Greaseman; Lighting & Traffic Signal Installation Equipment (includes all groups or classifications); Material Transfer Equipment (Shuttle Buggy) Asphalt; Pettibone-Rail Equipment; Power Grader; Power Scraper; Push Cat; Rotomill

(all), Grinders & Planers of All types; Trench Machine (24" wide & under); and Vermeer type Concrete Saw.

GROUP 3 - A-Frame; Air Compressor on Tunnel Work (low pressure); Asphalt Plant Engineer; Bobcat-type and/or Skid Steer Loader with or without Attachments; Highway Drills (all types); Locomotive (narrow gauge); Material Hoist/Elevator; Mixer, Concrete (more than one bag capacity); Mixer, one bag capacity (Side Loader); Power Boiler (Over 15 lbs. Pressure) Pump Operator installing & operating Well Points; Pump (4" & over discharge); Railroad Tie Inserter/Remover; Roller, Asphalt; Rotovator (lime soil stabilizer); Switch & Tie Tampers (without lifting & aligning device); Utility Operator (Small equipment); and Welding Machines; Articulating/straight bed end dumps if assigned (minus \$4.00 per hour.

GROUP 4 - Backfiller; Ballast Re-locator; Bars, Joint & Mesh Installing Machine; Batch Plant; Boring Machine Operator (48" or less); Bull Floats; Burlap & Curing Machine; Concrete Plant (capacity 4 yd. & under); Concrete Saw (Multiple); Conveyor (Highway); Crusher; Deckhand; Farm-type Tractor with attachments (highway); Finishing Machine; Fireperson, Floating Equipment (all types); Fork Lift; Form Trencher; Hydro Hammer expect masonry; Hydro Seeder; Pavement Breaker; Plant Mixer; Post Driver; Post Hole Digger (Power Auger); Power Brush Burner; Power Form Handling Equipment; Road Widening Trencher; Roller (Brick, Grade & Macadam); Self-Propelled Power Spreader; Self-Propelled Power Subgrader; Steam Fireperson; Tractor (Pulling Sheepfoot, Roller or Grader); and Vibratory Compactor with Integral Power.

GROUP 5 - Compressor (Portable, Sewer, Heavy & Highway); Drum Fireperson (Asphalt Plant); Generator; Masonary Forklift; Inboard-Outboard Motor Boat Launch; Oil Heater (asphalt plant); Oiler/Helper; Power Driven Heater; Power Sweeper & Scrubber; Pump (under 4" discharge); Signalperson; Tire Repairperson; VAC/ALLS; Cranes - Compact, track or rubber under 4,000 pound capacity; fueling and greasing; and Chainmen.

GROUP 6 - Master Mechanic & Boom from 150 to 180.

GROUP 7 - Boom from 180 and over.

 ENGI0066-023 06/01/2017

COLUMBIANA, MAHONING & TRUMBULL COUNTIES

	Rates	Fringes
POWER EQUIPMENT OPERATOR		
ASBESTOS; HAZARDOUS/TOXIC		
WASTE PROJECTS		
GROUP 1 - A & B.....	\$ 39.23	19.66
ASBESTOS; HAZARDOUS/TOXIC		
WASTE PROJECTS		
GROUP 2 - A & B.....	\$ 38.90	19.66
ASBESTOS; HAZARDOUS/TOXIC		
WASTE PROJECTS		
GROUP 3 - A & B.....	\$ 34.64	19.66
ASBESTOS; HAZARDOUS/TOXIC		
WASTE PROJECTS		

GROUP 4 - A & B.....\$ 30.70	19.66
ASBESTOS; HAZARDOUS/TOXIC WASTE PROJECTS	
GROUP 5 - A & B.....\$ 27.30	19.66
HAZARDOUS/TOXIC WASTE PROJECTS	
GROUP 1 - C & D.....\$ 35.96	19.66
HAZARDOUS/TOXIC WASTE PROJECTS	
GROUP 2 - C & D.....\$ 35.66	19.66
HAZARDOUS/TOXIC WASTE PROJECTS	
GROUP 3 - C & D.....\$ 31.76	19.66
HAZARDOUS/TOXIC WASTE PROJECTS	
GROUP 4 - C & D.....\$ 28.14	19.66
HAZARDOUS/TOXIC WASTE PROJECTS	
GROUP 5 - C & D.....\$ 25.03	19.66
ALL OTHER WORK	
GROUP 1.....\$ 32.69	19.66
ALL OTHER WORK	
GROUP 2.....\$ 32.42	19.66
ALL OTHER WORK	
GROUP 3.....\$ 28.87	19.66
ALL OTHER WORK	
GROUP 4.....\$ 25.58	19.66
ALL OTHER WORK	
GROUP 5.....\$ 22.75	19.66

GROUP 1 - Rig, Pile Driver or Caisson Type; & Rig, Pile Hydraulic Unit Attached

GROUP 2 - Asphalt Heater Planer; Backfiller with Drag Attachment; Backhoe; Backhoe with Shear attached; Backhoe-Rear Pivotal Swing; Batch Plant-Central Mix Concrete; Batch Plant, Portable concrete; Berm Builder-Automatic; Boat Derrick; Boat-Tug; Boring Machine Attached to Tractor; Bullclam; Bulldozer; C.M.I. Road Builder & Similar Type; Cable Placer & Layer; Carrier-Straddle; Carryall-Scraper or Scoop; Chicago Boom; Compactor with Blade Attached; Concrete Saw (Vermeer or similar type); Concrete Spreader Finisher; Combination, Bidwell Machine; Crane; Crane-Electric Overhead; Crane-Rough Terrain; Crane-Side Boom; Crane-Truck; Crane-Tower; Derrick-Boom; Derrick-Car; Digger-Wheel (Not trencher or road widener); Double Nine; Drag Line; Dredge; Drill-Kenny or Similar Type; Easy Pour Median Barrier Machine (or similar type); Electromatic; Frankie Pile; Gradall; Grader; Gurry; Self-Propelled; Heavy Equipment Robotics Operator/Mechanic; Hoist-Monorail; Hoist-Stationary & Mobile Tractor; Hoist, 2 or 3 drum; Horizontal Directional Drill Operator; Jackall; Jumbo Machine; Kocal & Kuhlman; Land-Seagoing Vehicle; Loader, Elevating; Loader, Front End; Loader, Skid Steer; Locomotive; Mechanic/Welder; Metro Chip Harvester with Boom; Mucking Machine; Paver-Asphalt Finishing Machine; Paver-Road Concrete; Paver-Slip Form (C.M.I. or similar); Place Crete Machine with Boom; Post Driver (Carrier mounted); Power Driven Hydraulic Pump & Jack (When used in Slip Form or Lift Slab Construction); Pump Crete Machine; Regulator-Ballast; Hydraulic Power Unit not attached to Rig for Pile Drillings; Rigs-Drilling; Roto Mill or similar Full Lane (8' Wide & Over); Roto Mill or similar type (Under 8'); Shovel; Slip Form Curb Machine; Speedwing;

Spikemaster; Stonecrusher; Tie Puller & Loader; Tie Tamper; Tractor-Double Boom; Tractor with Attachments; Truck-Boom; Truck-Tire; Trench Machine; Tunnel Machine (Mark 21 Java or similar); & Whirley (or similar type)

GROUP 3 - Asphalt Plant; Bending Machine (Pipeline or similar type); Boring machine, Motor Driven; Chip Harvester without Boom; Cleaning Machine, Pipeline Type; Coating Machine, Pipeline Type; Compactor; Concrete Belt Placer; Concrete Finisher; Concrete Planer or Asphalt; Concrete Spreader; Elevator; Fork Lift (Home building only); Fork lift & Lulls; Fork Lift Walk Behind (Hoisting over 1 buck high); Form Line Machine; Grease Truck operator; Grout Pump; Gunnite Machine; Horizontal Directional Drill Locator; Single Drum Hoist with or without Tower; Huck Bolting Machine; Hydraulic Scaffold (Hoisting building materials); Paving Breaker (Self-propelled or Ridden); Pipe Dream; Pot Fireperson (Power Agitated); Refrigeration Plant; Road Widener; Roller; Sasgen Derrick; Seeding Machine; Soil Stabilizer (Pump type); Spray Cure Machine, Self-Propelled; Straw Blower Machine; Sub-Grader; Tube Finisher or Broom C.M.I. or similar type; & Tugger Hoist

GROUP 4 - Air Curtain Destructor & Similar Type; Batch Plant-Job Related; Boiler Operator; Compressor; Conveyor; Curb Builder, self-propelled; Drill Wagon; Generator Set; Generator-Steam; Heater-Portable Power; Hydraulic Manipulator Crane; Jack-Hydraulic Power driven; Jack-Hydraulic (Railroad); Ladavator; Minor Machine Operator; Mixer-Concrete; Mulching Machine; Pin Puller; Power Broom; Pulverizer; Pump; Road Finishing Machine (Pull Type); Saw-Concrete-Self-Propelled (Highway Work); Signal Person; Spray Cure Machine-Motor Powered; Stump Cutter; Tractor; Trencher Form; Water Blaster; Steam Jenny; Syphon; Vibrator-Gasoline; & Welding Machine

GROUP 5 - Brakeperson; Fireperson; & Oiler

IRON0017-002 05/01/2021

ASHTABULA (North of Route 6, starting at the Geauga County Line, proceeding east to State Route 45), CUYAHOGA, ERIE (Eastern 2/3), GEAUGA, HURON (East of a line drawn from the north border through Monroeville & Willard), LAKE, LORAIN, MEDINA (North of Old Rte. #224), PORTAGE (West of a line from Middlefield to Shalersville to Deerfield), and SUMMIT (North of Old Rte. #224, including city limits of Barberton) COUNTIES

Rates Fringes

IRONWORKER

Ornamental, Reinforcing, &
Structural.....\$ 38.03 24.72

IRON0017-010 05/01/2021

ASHTABULA (Eastern part from Lake Erie on the north to route #322 on the south to include Conneaut, Kingsville, Sheffield, Denmark, Dorset, Cherry Valley, Wayne, Monroe, Pierpont, Richmond, Andover & Williamsfield Townships)

Rates Fringes

IRONWORKER

Structural, including
metal building erection &
Reinforcing.....\$ 38.03 24.72

IRON0044-001 06/01/2021

ADAMS (Western Part), BROWN, BUTLER (Southern Part), CLERMONT,
CLINTON (South of a line drawn from Blanchester to Lynchburg),
HAMILTON, HIGHLAND (Excluding eastern one-fifth & portion of
county inside lines drawn from Marshall to Lynchburg from the
northern county line through E. Monroe to Marshall) and WARREN
(South of a line drawn from Blanchester through Morrow to the
west county line) COUNTIES

	Rates	Fringes
IRONWORKER, REINFORCING.....	\$ 31.32	21.00
Beyond 30-mile radius of Hamilton County Courthouse..	\$ 28.67	21.20
Up to & including 30-mile radius of Hamilton County Courthouse.....	\$ 27.60	20.70

IRON0044-002 06/01/2021

CLINTON (South of a line drawn from Blanchester to Lynchburg),
HAMILTON, HIGHLAND (Excluding eastern one-fifth & portion of
county inside lines drawn from Marshall to Lynchburg from the
northern county line through E. Monroe to Marshall) & WARREN
(South of a line drawn from Blanchester through Morrow to the
west county line)

	Rates	Fringes
IRONWORKER		
Fence Erector.....	\$ 29.75	21.00
Ornamental; Structural.....	\$ 31.32	21.00

IRON0055-003 07/01/2021

CRAWFORD (Area Between lines drawn from where Hwy #598 & #30
meet through N. Liberty to the northern border & from said Hwy
junction point due west to the border), DEFIANCE (S. of a line
drawn from where Rte. #66 meets the northern line through
Independence to the eastern county border), ERIE (Western 1/3),
FULTON, HANCOCK, HARDIN (North of a line drawn from Maysville
to a point 4 miles south of the northern line on the eastern
line), HENRY, HURON (West of a line drawn from the northern
border through Monroeville & Willard), LUCAS, OTTAWA, PUTNAM
(East of a line drawn from the northern border down through
Miller City to where #696 meets the southern border), SANDUSKY,
SENECA, WILLIAMS (East of a line drawn from Pioneer through
Stryker to the southern border), WOOD & WYANDOT (North of Rte.
#30)

	Rates	Fringes
IRONWORKER		
Fence Erector.....	\$ 21.30	20.92
Flat Road Mesh.....	\$ 29.77	21.30

Tunnels & Caissons Under		
Pressure.....	\$ 29.77	21.30
All Other Work.....	\$ 31.25	26.90

IRON0147-002 06/01/2021

ALLEN (Northern half), DEFIANCE (Northern part, excluding south of a line drawn from where Rte. #66 meets the northern line through Independence to the eastern county border), MERCER (Northern half), PAULDING, PUTNAM (Western part, excluding east of a line drawn from the northern border down through Miller City to where #696 meets the southern border), VAN WERT, and WILLIAMS (Western part, excluding east of a line drawn from Pioneer through Stryker to the southern border) COUNTIES

	Rates	Fringes
IRONWORKER.....	\$ 30.35	23.40

IRON0172-002 06/01/2021

CHAMPAIGN (Eastern one-third), CLARK (Eastern one-fourth), COSHOCTON (West of a line beginning at the northwestern county line going through Walhonding & Tunnel Hill to the southern county line), CRAWFORD (South of Rte. #30), DELAWARE, FAIRFIELD, FAYETTE, FRANKLIN, HARDIN (Excluding a line drawn from Roundhead to Maysville), HIGHLAND (Eastern one-fifth), HOCKING, JACKSON (Northern half), KNOX, LICKING, LOGAN (Eastern one-third), MADISON, MARION, MORROW, MUSKINGUM (West of a line starting at Adams Mill going to Adamsville & going from Adamsville through Blue Rock to the southern border), PERRY, PICKAWAY, PIKE (Northern half), ROSS, UNION, VINTON and WYANDOT (South of Rte. #30) COUNTIES

	Rates	Fringes
IRONWORKER.....	\$ 32.00	21.00

IRON0207-004 06/01/2021

ASHTABULA (Southern part starting at the Geauga County line), COLUMBIANA (E. of a line from Damascus to Highlandtown), MAHONING (N. of Old Route #224), PORTAGE (E. of a line from Middlefield to Shalersville to Deerfield) & TRUMBULL

	Rates	Fringes
IRONWORKER		
Layout; Sheeter.....	\$ 32.07	26.00
Ornamental; Reinforcing;		
Structural.....	\$ 31.07	26.00
Ornamental; Reinforcing.....	\$ 29.72	25.18

IRON0290-002 06/01/2021

ALLEN (Southern half), AUGLAIZE, BUTLER (North of a line drawn from east to the west county line going through Oxford, Darrtown & Woodsdale), CHAMPAIGN (Excluding east of a line drawn from Catawla to the point where #68 intersects the northern county line), CLARK (Western two-thirds), CLINTON (Excluding south of a line drawn from Blanchester to Lynchburg), DARKE, GREENE, HIGHLAND (Inside lines drawn from

Marshall to Lynchburg & from the northern county line through East Monroe to Marshall), LOGAN (West of a line drawn from West Liberty to where the northern county line meets the western county line of Hardin), MERCER (Southern half), MIAMI, MONTGOMERY, PREBLE, SHELBY & WARREN (Excluding south of a line drawn from Blanchester through Morrow to the western county line) COUNTIES

	Rates	Fringes
IRONWORKER.....	\$ 30.99	23.10

IRON0549-003 12/01/2021		

BELMONT, GUERNSEY, HARRISON, JEFFERSON, MONROE & MUSKINGUM (Excluding portion west of a line starting at Adams Mill going to Adamsville and going from Adamsville through Blue Rock to the south border)

	Rates	Fringes
IRONWORKER.....	\$ 34.44	18.77

IRON0550-004 05/01/2021		

ASHLAND, CARROLL, COLUMBIANA (W. of a line from Damascus to Highlandtown), COSHOCTON (E. of a line beginning at NW Co. line going through Walhonding & Tunnel Hill to the South Co. line), HOLMES, HURON (S. of Old Rte. #224), MAHONING (S. of Old Rte. #224), MEDINA (S. of Old Rte. #224), PORTAGE (S. of Old Rte. #224), RICHLAND, STARK, SUMMIT (S. of Old Rte. #224, Excluding city limits of Barberton), TUSCARAWAS, & WAYNE

	Rates	Fringes
Ironworkers:Structural, Ornamental and Reinforcing.....	\$ 30.17	21.08

IRON0769-004 06/01/2021		

ADAMS (Eastern Half), GALLIA, JACKSON (Southern Half), LAWRENCE & SCIOTO

	Rates	Fringes
IRONWORKER.....	\$ 33.00	27.29

IRON0787-003 06/01/2021		

ATHENS, MEIGS, MORGAN, NOBLE, and WASHINGTON COUNTIES

	Rates	Fringes
IRONWORKER.....	\$ 31.94	23.05

LABO0265-008 05/01/2021		

	Rates	Fringes
LABORER ASHTABULA, ERIE, HURON,		

LORAIN, LUCAS, MAHONING, MEDINA, OTTAWA, PORTAGE, SANDUSKY, STARK, SUMMIT, TRUMBULL & WOOD COUNTIES		
GROUP 1.....	\$ 33.70	11.85
GROUP 2.....	\$ 33.87	11.85
GROUP 3.....	\$ 34.20	11.85
GROUP 4.....	\$ 34.65	11.85
CUYAHOGA AND GEauga COUNTIES ONLY: SEWAGE PLANTS, WASTE PLANTS, WATER TREATMENT FACILITIES, PUMPING STATIONS, & ETHANOL PLANTS		
CONSTRUCTION.....	\$ 34.93	11.85
CUYAHOGA, GEauga & LAKE COUNTIES		
GROUP 1.....	\$ 34.93	11.85
GROUP 2.....	\$ 35.10	11.85
GROUP 3.....	\$ 35.43	11.85
GROUP 4.....	\$ 35.88	11.85
REMAINING COUNTIES OF OHIO		
GROUP 1.....	\$ 33.27	11.85
GROUP 2.....	\$ 33.44	11.85
GROUP 3.....	\$ 33.77	11.85
GROUP 4.....	\$ 35.88	11.85

LABORER CLASSIFICATIONS

GROUP 1 - Asphalt Laborer; Carpenter Tender; Concrete Curing Applicator; Dump Man (Batch Truck); Guardrail and Fence Installer; Joint Setter; Laborer (Construction); Landscape Laborer; Mesh Handlers & Placer; Right-of-way Laborer; Riprap Laborer & Grouter; Scaffold Erector; Seal Coating; Surface Treatment or Road Mix Laborer; Sign Installer; Slurry Seal; Utility Man; Bridge Man; Handyman; Waterproofing Laborer; Flagperson; Hazardous Waste (level D); Diver Tender; Zone Person & Traffic Control

GROUP 2 - Asphalt Raker; Concrete Puddler; Kettle Man Pipeline); Machine Driven Tools (Gas, Electric, Air); Mason Tender; Brick Paver; Mortar Mixer; Power Buggy or Power Wheelbarrow; Paint Stripper; Sheeting & Shoring Man; Surface Grinder Man; Plastic Fusing Machine Operator; Pug Mill Operator; & Vacuum Devices (wet or dry); Rodding Machine Operator; Diver; Screwman or Paver; Screed Person; Water Blast, Hand Held Wand; Pumps 4" & Under (Gas, Air or Electric) & Hazardous Waste (level C); Air Track and Wagon Drill; Bottom Person; Cofferdam (below 25 ft. deep); Concrete Saw Person; Cutting with Burning Torch; Form Setter; Hand Spiker (Railroad); Pipelayer; Tunnel Laborer (without air) & Caisson; Underground Person (working in Sewer and Waterline, Cleaning, Repairing & Reconditioning); Sandblaster Nozzle Person; & Hazardous Waste (level B)

GROUP 3 - Blaster; Mucker; Powder Person; Top Lander; Wrencher (Mechanical Joints & Utility Pipeline); Yarnier; Hazardous Waste (level A); Concrete Specialist; Concrete Crew in Tunnels (With Air-pressurized - \$1.00 premium); Curb Setter & Cutter; Grade Checker; Utility Pipeline Tapper; Waterline; and Caulker

GROUP 4 - Miner (With Air-pressurized - \$1.00 premium); & Gunite Nozzle Person

TUNNEL LABORER WITH AIR-PRESSURIZED ADD \$1.00 TO BASE RATE

SIGNAL PERSON WILL RECEIVE THE RATE EQUAL TO THE RATE PAID THE LABORER CLASSIFICATION FOR WHICH HE OR SHE IS SIGNALING.

 PAIN0006-002 05/01/2018

ASHTABULA, CUYAHOGA, GEAUGA, LAKE, LORAIN, PORTAGE (N. of the East-West Turnpike) & SUMMIT (N. of the East-West Turnpike)

	Rates	Fringes
PAINTER		
COMMERCIAL NEW WORK; REMODELING; & RENOVATIONS		
GROUP 1.....	\$ 27.90	16.16
GROUP 2.....	\$ 28.30	16.16
GROUP 3.....	\$ 28.60	16.16
GROUP 4.....	\$ 34.16	16.16
COMMERCIAL REPAINT		
GROUP 1.....	\$ 26.40	16.16
GROUP 2.....	\$ 26.80	16.16
GROUP 3.....	\$ 27.10	16.16

PAINTER CLASSIFICATIONS - COMMERCIAL NEW WORK; REMODELING; & RENOVATIONS

GROUP 1 - Brush; & Roller

GROUP 2 - Sandblasting & Buffing

GROUP 3 - Spray Painting; Closed Steel Above 55 feet; Bridges & Open Structural Steel; Tanks - Water Towers; Bridge Painters; Bridge Riggers; Containment Builders

GROUP 4 - Bridge Blaster

PAINTER CLASSIFICATIONS - COMMERCIAL REPAINT

GROUP 1 - Brush; & Roller

GROUP 2 - Sandblasting & Buffing

GROUP 3 - Spray Painting

 PAIN0007-002 07/01/2021

FULTON, HENRY, LUCAS, OTTAWA (Excluding Allen, Bay, Bono, Catawba Island, Clay Center, Curtice, Danbury, Eagle Beach, Elliston, Elmore, Erie, Fishback, Gem Beach & Genova) & WOOD

	Rates	Fringes
PAINTER		
NEW COMMERCIAL WORK		
GROUP 1.....	\$ 28.74	18.77
GROUP 2.....	\$ 28.74	18.77
GROUP 3.....	\$ 28.74	18.77
GROUP 4.....	\$ 28.74	18.77
GROUP 5.....	\$ 28.74	18.77
GROUP 6.....	\$ 28.74	18.77

GROUP 7.....	\$ 28.74	18.77
GROUP 8.....	\$ 28.74	18.77
GROUP 9.....	\$ 28.74	18.77

REPAINT IS 90% OF JR

PAINTER CLASSIFICATIONS

GROUP 1 - Brush; Spray & Sandblasting Pot Tender

GROUP 2 - Refineries & Refinery Tanks; Surfaces 30 ft. or over where material is applied to or labor performed on above ground level (exterior), floor level (interior)

GROUP 3 - Swing Stage & Chair

GROUP 4 - Lead Abatement

GROUP 5 - All Methods of Spray

GROUP 6 - Solvent-Based Catalized Epoxy Materials of 2 or More Component Materials, to include Solvent-Based Conversion Varnish (excluding water based)

GROUP 7 - Spray Solvent Based Material; Sand & Abrasive Blasting

GROUP 8 - Towers; Tanks; Bridges; Stacks Over 30 Feet

GROUP 9 - Epoxy Spray (excluding water based)

PAIN0012-008 05/01/2019

BUTLER COUNTY

	Rates	Fringes
PAINTER		
GROUP 1.....	\$ 21.95	10.20
GROUP 2.....	\$ 25.30	10.20
GROUP 3.....	\$ 25.80	10.20
GROUP 4.....	\$ 26.05	10.20
GROUP 5.....	\$ 26.30	10.20

PAINTER CLASSIFICATIONS

GROUP 1: Bridge Equipment Tender; Bridge/Containment Builder

GROUP 2: Brush & Roller

GROUP 3: Spray

GROUP 4: Sandblasting; & Waterblasting

GROUP 5: Elevated Tanks; Steeplejack Work; Bridge; & Lead Abatement

PAIN0012-010 05/01/2019

BROWN, CLERMONT, CLINTON, HAMILTON & WARREN

	Rates	Fringes
--	-------	---------

PAINTER

HEAVY & HIGHWAY BRIDGES-
GUARDRAILS-LIGHTPOLES-
STRIPING

Bridge Equipment Tender and Containment Builder....\$ 21.95	10.20
Bridges when highest point of clearance is 60 feet or more; & Lead Abatement Projects.....\$ 26.30	10.20
Brush & Roller.....\$ 25.30	10.20
Sandblasting & Hopper Tender; Water Blasting.....\$ 26.05	10.20
Spray.....\$ 25.80	10.20

PAIN0093-001 12/01/2018

ATHENS, GUERNSEY, HOCKING, MONROE, MORGAN, NOBLE and
WASHINGTON COUNTIES

Rates Fringes

PAINTER

Bridges; Locks; Dams; Tension Towers; & Energized Substations.....\$ 34.04	18.50
Power Generating Facilities.\$ 30.89	18.50

PAIN0249-002 06/01/2020

CLARK, DARKE, GREENE, MIAMI, MONTGOMERY & PREBLE

Rates Fringes

PAINTER

GROUP 1 - Brush & Roller....\$ 24.17	11.22
GROUP 2 - Swing, Scaffold Bridges; Structural Steel; Open Acid Tank; High Tension Electrical Equipment; & Hot Pipes.....\$ 24.17	11.22
GROUP 3 - Spray; Sandblast; Steamclean; Lead Abatement.....\$ 24.92	11.22
GROUP 4 - Steeplejack Work..\$ 25.12	11.22
GROUP 5 - Coal Tar.....\$ 25.67	11.22
GROUP 6 - Bridge Equipment Tender & or Containment Builder.....\$ 32.88	11.22
GROUP 7 - Tanks, Stacks & Towers.....\$ 27.81	11.22
GROUP 8 - Bridge Blaster, Rigger.....\$ 35.88	11.22

PAIN0356-002 09/01/2009

KNOX, LICKING, MUSKINGUM, and PERRY

Rates Fringes

PAINTER

Bridge Equipment Tenders and Containment Builders....\$ 27.93	7.25
------------------------------------------------------------------	------

Bridges; Blasters; and Riggers.....	\$ 34.60	7.25
Brush and Roller.....	\$ 20.93	7.25
Sandblasting; Steam Cleaning; Waterblasting; and Hazardous Work.....	\$ 25.82	7.25
Spray.....	\$ 21.40	7.25
Structural Steel and Swing Stage.....	\$ 25.42	7.25
Tanks; Stacks; and Towers...	\$ 28.63	7.25

PAIN0438-002 12/01/2021

BELMONT, HARRISON and JEFFERSON COUNTIES

Rates Fringes

PAINTER

Bridges, Locks, Dams, Tension Towers & Energized Substations.....	\$ 34.47	20.60
Power Generating Facilities.	\$ 29.65	17.68

PAIN0476-001 06/01/2021

COLUMBIANA, MAHONING, and TRUMBULL COUNTIES

Rates Fringes

PAINTER

GROUP 1.....	\$ 25.79	15.81
GROUP 2.....	\$ 33.10	15.81
GROUP 3.....	\$ 26.00	15.81
GROUP 4.....	\$ 27.12	15.81
GROUP 5.....	\$ 27.79	15.81
GROUP 6.....	\$ 26.69	15.81
GROUP 7.....	\$ 27.79	15.81

PAINTER CLASSIFICATIONS:

GROUP 1: Painters, Brush & Roller

GROUP 2: Bridges

GROUP 3: Structural Steel

GROUP 4: Spray, Except Bar Joist/Deck

GROUP 5: Epoxy/Mastic; Spray- Bar Joist/Deck; Working Above
50 Feet; and Swingstages

GROUP 6: Tanks; Sandblasting

GROUP 7: Towers; Stacks

PAIN0555-002 06/01/2021

ADAMS, HIGHLAND, JACKSON, PIKE & SCIOTO

Rates Fringes

PAINTER

GROUP 1.....	\$ 31.95	17.05
GROUP 2.....	\$ 33.47	17.05

GROUP 3.....	\$ 34.99	17.05
GROUP 4.....	\$ 37.97	17.05

PAINTER CLASSIFICATIONS

GROUP 1 - Containment Builder

GROUP 2 - Brush; Roller; Power Tools, Under 40 feet

GROUP 3 - Sand Blasting; Spray; Steam Cleaning; Pressure Washing; Epoxy & Two Component Materials; Lead Abatement; Hazardous Waste; Toxic Materials; Bulk & Storage Tanks of 25,000 Gallon Capacity or More; Elevated Tanks

GROUP 4 - Stacks; Bridges

PAIN0639-001 05/01/2011

	Rates	Fringes
Sign Painter & Erector.....	\$ 20.61	3.50+a+b+c

FOOTNOTES: a. 7 Paid Holidays: New Year's Day; Memorial Day; July 4th; Labor Day; Thanksgiving Day; Christmas Day & 1 Floating Day
b. Vacation Pay: After 1 year's service - 5 days' paid vacation; After 2, but less than 10 years' service - 10 days' paid vacation; After 10, but less than 20 years' service - 15 days' paid vacation; After 20 years' service - 20 days' paid vacation
c. Funeral leave up to 3 days maximum paid leave for death of mother, father, brother, sister, spouse, child, mother-in-law, father-in-law, grandparent and inlaw provided employee attends funeral

PAIN0788-002 06/01/2020

ASHLAND, CRAWFORD, ERIE, HANCOCK, HURON, MARION, MORROW, OTTAWA (Allen, Bay, Bono, Catawba Island, Clay Center, Curtice, Danbury, Eagle Beach, Elliston, Elmore, Erie, Fishback, Gem Beach & Genoa), RICHLAND, SANDUSKY, SENECA & WYANDOT

	Rates	Fringes
PAINTER		
Brush & Roller.....	\$ 24.66	14.05
Structural Steel.....	\$ 26.26	14.05

WINTER REPAINT: Between December 1 to March 31 - 90%JR

\$.50 PER HOUR SHALL BE ADDED TO THE RATE OF PAY FOR THE CLASSIFICATION OF WORK:

While working swingstage, boatswain chair, needle beam and horizontal cable. While operating sprayguns, sandblasting, cobblasting and high pressure waterblasting (4000psi).

\$1.00 PER HOUR SHALL BE ADDED TO THE RATE OF PAY FOR THE CLASSIFICATION OF WORK:

For the application of catalized epoxy, including latex epoxy that is deemed hazardous, lead abatement, or for work or

material where special precautions beyond normal work duties must be taken. For working on stacks, tanks, and towers over 40 feet in height.

PAIN0813-005 12/01/2008

GALLIA, LAWRENCE, MEIGS & VINTON

	Rates	Fringes
PAINTER		
Base Rate.....	\$ 24.83	10.00
Bridges, Locks, Dams &		
Tension Towers.....	\$ 27.83	10.00

PAIN0841-001 06/01/2018

MEDINA, PORTAGE (South of and including Ohio Turnpike), and
SUMMIT (South of and including Ohio Turnpike) COUNTIES

	Rates	Fringes
Painters:		
GROUP 1.....	\$ 25.75	14.35
GROUP 2.....	\$ 26.40	14.35
GROUP 3.....	\$ 26.50	14.35
GROUP 4.....	\$ 26.60	14.35
GROUP 5.....	\$ 27.00	14.35
GROUP 6.....	\$ 39.20	11.75
GROUP 7.....	\$ 27.00	14.35

PAINTER CLASSIFICATIONS:

GROUP 1 - Brush, Roller & Paperhanger

GROUP 2 - Epoxy Application

GROUP 3 - Swing Scaffold, Bosum Chair, & Window Jack

GROUP 4 - Spray Gun Operator of Any & All Coatings

GROUP 5 - Sandblast, Painting of Standpipes, etc. from
Scaffolds, Bridge Work and/or Open Structural Steel,
Standpipes and/or Water Towers

GROUP 6 - Public & Commerce Transportation, Steel or
Galvanized, Bridges, Tunnels & Related Support Items
(concrete)

GROUP 7 - Synthetic Exterior, Drywall Finisher and/or Taper,
Drywall Finisher and Follow-up Man Using Automatic Tools

PAIN0841-002 06/01/2018

CARROLL, COSHOCTON, HOLMES, STARK, TUSCARAWAS & WAYNE

	Rates	Fringes
PAINTER		
Bridges; Towers, Poles &		
Stacks; Sandblasting		
Steel; Structural Steel &		

Metalizing.....	\$ 22.78	13.63
Brush & Roller.....	\$ 21.77	13.63
Spray; Tank Interior & Exterior.....	\$ 22.60	13.63

PAIN1020-002 07/01/2020

ALLEN, AUGLAIZE, CHAMPAIGN, DEFIANCE, HARDIN, LOGAN, MERCER,
PAULDING, PUTNAM, SHELBY, VAN WERT, and WILLIAMS COUNTIES

	Rates	Fringes
PAINTER		
Brush & Roller.....	\$ 25.22	14.11
Drywall Finishing & Taping..	\$ 23.92	14.11
Lead Abatement.....	\$ 26.97	14.11
Spray, Sandblasting Pressure Cleaning, & Refinery.....	\$ 25.87	14.11
Swing Stage, Chair, Spiders, & Cherry Pickers...	\$ 25.47	14.11
Wallcoverings.....	\$ 22.82	14.11

All surfaces 40 ft. or over where material is applied to or
labor performed on, above ground level (exterior), floor
level (interior) - \$.50 premium

Applying Coal Tar Products - \$1.00 premium

PAIN1275-002 06/01/2020

DELAWARE, FAIRFIELD, FAYETTE, FRANKLIN, MADISON, PICKAWAY, ROSS
& UNION

	Rates	Fringes
PAINTER		
Bridges.....	\$ 34.64	14.40
Brush; Roller.....	\$ 25.16	14.40
Sandblasting; Steamcleaning; Waterblasting (3500 PSI or Over)& Hazardous Work.....	\$ 25.86	14.40
Spray.....	\$ 25.66	14.40
Stacks; Tanks; & Towers.....	\$ 28.67	14.40
Structural Steel & Swing Stage.....	\$ 25.46	14.40

PLAS0109-001 05/01/2018

MEDINA, PORTAGE, STARK, and SUMMIT COUNTIES

	Rates	Fringes
PLASTERER.....	\$ 28.86	17.11

PLAS0109-003 05/01/2018

CARROLL, HOLMES, TUSCARAWAS, and WAYNE COUNTIES

	Rates	Fringes
--	-------	---------

PLASTERER.....	\$ 28.21	17.11
----------------	----------	-------

PLAS0132-002 05/01/2018

BROWN, BUTLER, CLERMONT, HAMILTON, HIGHLAND, WARREN COUNTIES

	Rates	Fringes
--	-------	---------

PLASTERER.....	\$ 28.86	17.11
----------------	----------	-------

PLAS0404-002 05/01/2018

ASHTABULA, CUYAHOGA, GEAUGA, AND LAKE COUNTIES

	Rates	Fringes
--	-------	---------

PLASTERER.....	\$ 29.63	17.11
----------------	----------	-------

PLAS0404-003 05/01/2018

LORAIN COUNTY

	Rates	Fringes
--	-------	---------

PLASTERER.....	\$ 28.86	17.11
----------------	----------	-------

PLAS0526-022 05/01/2018

COLUMBIANA, MAHONING, and TRUMBULL COUNTIES

	Rates	Fringes
--	-------	---------

PLASTERER.....	\$ 28.86	17.11
----------------	----------	-------

PLAS0526-023 05/01/2018

BELMONT, HARRISON, and JEFFERSON COUNTIES

	Rates	Fringes
--	-------	---------

PLASTERER.....	\$ 28.21	17.11
----------------	----------	-------

PLAS0886-001 05/01/2018

FULTON, HANCOCK, HENRY, LUCAS, PUTNAM, and WOOD COUNTIES

	Rates	Fringes
--	-------	---------

PLASTERER.....	\$ 29.63	17.11
----------------	----------	-------

PLAS0886-003 05/01/2018

DEFIANCE, ERIE, HURON, OTTAWA, PAULDING, SANDUSKY, and SENECA COUNTIES

	Rates	Fringes
--	-------	---------

PLASTERER.....	\$ 28.86	17.11
----------------	----------	-------

PLAS0886-004 05/01/2018

ALLEN, AUGLAIZE, HARDIN, LOGAN, MERCER, and VAN WERT COUNTIES

	Rates	Fringes
--	-------	---------

PLASTERER.....\$ 28.21 17.11

PLUM0042-002 07/01/2020

ASHLAND, CRAWFORD, ERIE, HURON, KNOX, LORAIN, MORROW, RICHLAND
 & WYANDOT

Rates Fringes

Plumber, Pipefitter,
 Steamfitter.....\$ 34.82 24.67

PLUM0050-002 07/06/2020

DEFIANCE, FULTON, HANCOCK, HENRY, LUCAS, OTTAWA, PAULDING,
 PUTNAM, SANDUSKY, SENECA, WILLIAMS & WOOD

Rates Fringes

Plumber, Pipefitter,
 Steamfitter.....\$ 43.60 26.73

PLUM0055-003 05/04/2021

ASHTABULA, CUYAHOGA, GEAUGA, LAKE, MEDINA (N. of Rte. #18 &
 Smith Road) & SUMMIT (N. of Rte. #303, including the corporate
 limits of the city of Hudson)

Rates Fringes

PLUMBER.....\$ 38.47 28.07

PLUM0083-001 07/01/2017

BELMONT & MONROE (North of Rte. #78)

Rates Fringes

Plumber and Steamfitter.....\$ 32.16 31.51

PLUM0094-002 05/01/2020

CARROLL (Northen Half), STARK, and WAYNE COUNTIES

Rates Fringes

PLUMBER/PIPEFITTER.....\$ 35.78 21.44

PLUM0120-002 05/03/2021

ASHTABULA, CUYAHOGA, GEAUGA, LAKE, LORAIN (the C.E.I. Power
 House in Avon Lake), MEDINA (N. of Rte. #18) & SUMMIT (N. of
 #303)

Rates Fringes

PIPEFITTER.....\$ 41.72 26.30

PLUM0162-002 06/01/2021

CHAMPAIGN, CLARK, CLINTON, DARKE, FAYETTE, GREENE, MIAMI,
MONTGOMERY & PREBLE

Rates Fringes

Plumber, Pipefitter,
Steamfitter.....\$ 33.40 27.09

PLUM0168-002 06/01/2021

MEIGS, MONROE (South of Rte. #78), MORGAN (South of Rte. #78)
& WASHINGTON

Rates Fringes

PLUMBER/PIPEFITTER.....\$ 37.09 33.26

PLUM0189-002 06/01/2019

DELAWARE, FAIRFIELD, FRANKLIN, HOCKING, LICKING, MADISON,
MARION, PERRY, PICKAWAY, ROSS & UNION

Rates Fringes

Plumber, Pipefitter,
Steamfitter.....\$ 38.45 16.98

PLUM0219-002 06/01/2021

MEDINA (Rte. #18 from eastern edge of Medina Co., west to
eastern corporate limits of the city of Medina, & on the county
road from the west corporate limits of Medina running due west
to and through community of Risley to the western edge of
Medina County - All territory south of this line), PORTAGE, and
SUMMIT (S. of Rte. #303) COUNTIES

Rates Fringes

Plumber and Steamfitter.....\$ 40.42 24.66

PLUM0392-002 06/01/2021

BROWN, BUTLER, CLERMONT, HAMILTON & WARREN

Rates Fringes

PLUMBER/PIPEFITTER.....\$ 35.21 22.99

PLUM0396-001 06/01/2021

COLUMBIANA (Excluding Washington & Yellow Creek Townships &
Liverpool Twp. - Secs. 35 & 36 - West of County Road #427),
MAHONING and TRUMBULL COUNTIES

Rates Fringes

PLUMBER/PIPEFITTER.....\$ 35.35 27.01

PLUM0495-002 06/01/2018

CARROLL (Rose, Monroe, Union, Lee, Orange, Perry & Loudon Townships), COLUMBIANA (Washington & Yellow Creek Townships & Liverpool Township, Secs. 35 & 36, West of County Rd. #427), COSHOCTON, GUERNSEY, HARRISON, HOLMES, JEFFERSON, MORGAN (South to State Rte. #78 & from McConnelville west on State Rte. #37 to the Perry County line), MUSKINGUM, NOBLE, and TUSCARAWAS COUNTIES

	Rates	Fringes
Plumber, Pipefitter, Steamfitter.....	\$ 38.24	23.09

PLUM0577-002 06/01/2019		

ADAMS, ATHENS, GALLIA, HIGHLAND, JACKSON, LAWRENCE, PIKE, SCIOTO & VINTON

	Rates	Fringes
Plumber, Pipefitter, Steamfitter.....	\$ 34.90	24.11

PLUM0776-002 07/01/2020		

ALLEN, AUGLAIZE, HARDIN, LOGAN, MERCER, SHELBY and VAN WERT COUNTIES

	Rates	Fringes
Plumber, Pipefitter, Steamfitter.....	\$ 37.63	25.58

TEAM0377-003 05/01/2021		

STATEWIDE, EXCEPT CUYAHOGA, GEAUGA & LAKE

	Rates	Fringes
TRUCK DRIVER		
GROUP 1.....	\$ 29.74	15.70
GROUP 2.....	\$ 30.16	15.70

TRUCK DRIVER CLASSIFICATIONS

GROUP 1 - Asphalt Distributor; Batch; 4- Wheel Service; 4-Wheel Dump; Oil Distributor & Tandem

GROUP 2 - Tractor-Trailer Combination: Fuel; Pole Trailer; Ready Mix; Semi-Tractor; & Asphalt Oil Spraybar Man When Operated From Cab; 5 Axles & Over; Belly Dump; End Dump; Articulated Dump; Heavy Duty Equipment; Low Boy; & Truck Mechanic

TEAM0436-002 05/01/2021		
CUYAHOGA, GEAUGA & LAKE		

	Rates	Fringes
TRUCK DRIVER		

GROUP 1.....	\$ 30.65	16.95
GROUP 2.....	\$ 31.15	16.95

GROUP 1: Straight & Dump, Straight Fuel

GROUP 2: Semi Fuel, Semi Tractor, Euclids, Darts, Tank, Asphalt Spreaders, Low Boys, Carry-All, Tourna-Rockers, Hi-Lifts, Extra Long Trailers, Semi-Pole Trailers, Double Hook-Up Tractor Trailers including Team Track & Railroad Siding, Semi-Tractor & Tri-Axle Trailer, Tandem Tractor & Tandem Trailer, Tag Along Trailer, Expandable Trailer or Towing Requiring Road Permits, Ready-Mix (Agitator or Non-Agitator), Bulk Concrete Driver, Dry Batch Truck, Articulated End Dump

WELDERS - Receive rate prescribed for craft performing operation to which welding is incidental.

=====

** Workers in this classification may be entitled to a higher minimum wage under Executive Order 14026 (\$15.00) or 13658 (\$11.25). Please see the Note at the top of the wage determination for more information.

Note: Executive Order (EO) 13706, Establishing Paid Sick Leave for Federal Contractors applies to all contracts subject to the Davis-Bacon Act for which the contract is awarded (and any solicitation was issued) on or after January 1, 2017. If this contract is covered by the EO, the contractor must provide employees with 1 hour of paid sick leave for every 30 hours they work, up to 56 hours of paid sick leave each year. Employees must be permitted to use paid sick leave for their own illness, injury or other health-related needs, including preventive care; to assist a family member (or person who is like family to the employee) who is ill, injured, or has other health-related needs, including preventive care; or for reasons resulting from, or to assist a family member (or person who is like family to the employee) who is a victim of, domestic violence, sexual assault, or stalking. Additional information on contractor requirements and worker protections under the EO is available at <https://www.dol.gov/agencies/whd/government-contracts>.

Unlisted classifications needed for work not included within the scope of the classifications listed may be added after award only as provided in the labor standards contract clauses (29CFR 5.5 (a) (1) (ii)).

The body of each wage determination lists the classification and wage rates that have been found to be prevailing for the cited type(s) of construction in the area covered by the wage determination. The classifications are listed in alphabetical order of "identifiers" that indicate whether the particular rate is a union rate (current union negotiated rate for local), a survey rate (weighted average rate) or a union average rate (weighted union average rate).

Union Rate Identifiers

A four letter classification abbreviation identifier enclosed in dotted lines beginning with characters other than ""SU"" or ""UAVG"" denotes that the union classification and rate were prevailing for that classification in the survey. Example: PLUM0198-005 07/01/2014. PLUM is an abbreviation identifier of the union which prevailed in the survey for this classification, which in this example would be Plumbers. 0198 indicates the local union number or district council number where applicable, i.e., Plumbers Local 0198. The next number, 005 in the example, is an internal number used in processing the wage determination. 07/01/2014 is the effective date of the most current negotiated rate, which in this example is July 1, 2014.

Union prevailing wage rates are updated to reflect all rate changes in the collective bargaining agreement (CBA) governing this classification and rate.

Survey Rate Identifiers

Classifications listed under the ""SU"" identifier indicate that no one rate prevailed for this classification in the survey and the published rate is derived by computing a weighted average rate based on all the rates reported in the survey for that classification. As this weighted average rate includes all rates reported in the survey, it may include both union and non-union rates. Example: SULA2012-007 5/13/2014. SU indicates the rates are survey rates based on a weighted average calculation of rates and are not majority rates. LA indicates the State of Louisiana. 2012 is the year of survey on which these classifications and rates are based. The next number, 007 in the example, is an internal number used in producing the wage determination. 5/13/2014 indicates the survey completion date for the classifications and rates under that identifier.

Survey wage rates are not updated and remain in effect until a new survey is conducted.

Union Average Rate Identifiers

Classification(s) listed under the UAVG identifier indicate that no single majority rate prevailed for those classifications; however, 100% of the data reported for the classifications was union data. EXAMPLE: UAVG-OH-0010 08/29/2014. UAVG indicates that the rate is a weighted union average rate. OH indicates the state. The next number, 0010 in the example, is an internal number used in producing the wage determination. 08/29/2014 indicates the survey completion date for the classifications and rates under that identifier.

A UAVG rate will be updated once a year, usually in January of each year, to reflect a weighted average of the current negotiated/CBA rate of the union locals from which the rate is based.

WAGE DETERMINATION APPEALS PROCESS

1.) Has there been an initial decision in the matter? This can be:

- * an existing published wage determination
- * a survey underlying a wage determination
- * a Wage and Hour Division letter setting forth a position on a wage determination matter
- * a conformance (additional classification and rate) ruling

On survey related matters, initial contact, including requests for summaries of surveys, should be with the Wage and Hour National Office because National Office has responsibility for the Davis-Bacon survey program. If the response from this initial contact is not satisfactory, then the process described in 2.) and 3.) should be followed.

With regard to any other matter not yet ripe for the formal process described here, initial contact should be with the Branch of Construction Wage Determinations. Write to:

Branch of Construction Wage Determinations
Wage and Hour Division
U.S. Department of Labor
200 Constitution Avenue, N.W.
Washington, DC 20210

2.) If the answer to the question in 1.) is yes, then an interested party (those affected by the action) can request review and reconsideration from the Wage and Hour Administrator (See 29 CFR Part 1.8 and 29 CFR Part 7). Write to:

Wage and Hour Administrator
U.S. Department of Labor
200 Constitution Avenue, N.W.
Washington, DC 20210

The request should be accompanied by a full statement of the interested party's position and by any information (wage payment data, project description, area practice material, etc.) that the requestor considers relevant to the issue.

3.) If the decision of the Administrator is not favorable, an interested party may appeal directly to the Administrative Review Board (formerly the Wage Appeals Board). Write to:

Administrative Review Board
U.S. Department of Labor
200 Constitution Avenue, N.W.
Washington, DC 20210

4.) All decisions by the Administrative Review Board are final.

=====
END OF GENERAL DECISIO"

Construction Bid Package

**A REPRINT OF THE U.S. DEPARTMENT OF HOUSING AND URBAN DEVELOPMENT'S
FEDERAL LABOR STANDARDS PROVISIONS, HUD-4010 DATED 2/84 (REVISED)**

Applicability

The Project or Program to which the construction work covered by this contract pertains is being assisted by the United States of America and the following Federal Labor Standards Provisions are included in this contract pursuant to the provisions applicable to such Federal assistance.

A.1.(i) Minimum Wages. All laborers and mechanics employed or working upon the site of the work (or under the United States Housing Act of 1937 or under the Housing Act of 1949 in the construction or development of the project), will be paid unconditionally and not less often than once a week, and without subsequent deduction or rebate on any account [except such payroll deductions as are permitted by regulations issued by the Secretary of Labor under the Copeland Act (29 CFR Part 3)], the full amount of wages and bona fide fringe benefits (or cash equivalents thereof) due at time of payment computed at rates not less than those contained in the wage determination of the Secretary of Labor which is attached hereto and made a part hereof, regardless of any contractual relationship which may be alleged to exist between the contractor and such laborers and mechanics. Contributions made or costs reasonably anticipated for bona fide fringe benefits under Section 1(b)(2) of the Davis-Bacon Act on behalf of laborers or mechanics are considered wages paid to such laborers or mechanics, subject to the provisions of 29 CFR 5.5(a)(a)(iv); also, regular contributions made or costs incurred for more than a weekly period (but not less often than quarterly) under plans, funds, or programs, which cover the particular weekly period, are deemed to be constructively made or incurred during such weekly period.

Such laborers and mechanics shall be paid the appropriate wage rate and fringe benefits on the wage determination for the classification of work actually performed, without regard to skill, except as provided in 29 CFR Part 5.5(a)(4). Laborers or mechanics performing work in more than one classification may be compensated at the rate specified for each classification for the time actually worked therein: Provided, that the employer's payroll records accurately set forth the time spent in each classification in which work is performed. The wage determination (including any additional classification and wage rates conformed under 29 CFR Part 5.5(a)(1)(ii) and the Davis-Bacon poster (WH-1321) shall be posted at all times by the contractor and its subcontracts at the site of the work in a prominent and accessible place where it can easily be seen by the workers.

(ii)(a) Any class of laborers or mechanics which is not listed in the wage determination and which is to be employed under the contract shall be classified in conformance with the wage determination. HUD shall approve an additional classification and wage rate and fringe benefits therefore only when the following criteria have been met:

- (1) The work to be performed by the classification request is not performed by a classification in the wage determination; and
- (2) The classification is utilized in the area by the construction industry; and
- (3) The proposed wage rate, including any bona fide fringe benefits, bears a reasonable relationship to the wage rates contained in the wage determination.

(ii)(b) If the contractor and the laborers and mechanics to be employed in the classification (if known), or their representatives, and HUD or its designee agree on the classification and wage rate (including the amount designated for fringe benefits where appropriate), a report of the action taken shall be sent to HUD or its designee to the Administrator of the Wage and Hour Division, Employment Standards Administration, U.S. Department of Labor, Washington, D.C. 20210. The

Construction Bid Package

Administrator, or an authorized representative, will approve, modify, or disapprove every additional classification action within 30 days of receipt and so advise HUD or its designee or will notify HUD or its designee within the 30-day period that additional time is necessary. (Approved by the Office of Management and Budget under OMB control number 1215-0140.)

- (ii)(c)** In the event the contractor, the laborers or mechanics to be employed in the classification or their representatives, and HUD or its designee do not agree on the proposed classification and wage rate (including the amount designated for fringe benefits, where appropriate), HUD or its designee shall refer the questions, including the views of all interested parties and the recommendation of HUD or its designee, to the Administrator for determination. The Administrator, or an authorized representative, will issue a determination within 30 days of receipt and so advise HUD or its designee or will notify HUD or its designee within the 30-day period that additional time is necessary. (Approved by the Office of Management and Budget under OMB Control Number 1215-0140.)
 - (ii)(d)** The wage rate (including fringe benefits where appropriate) determined pursuant to subparagraphs (1)(b) or (c) of this paragraph shall be paid to all workers performing work in the classification under this contract from the first day on which work is performed in the classification.
 - (iii)** Whenever the minimum wage rate prescribed in the contract for a class of laborers or mechanics includes a fringe benefit which is not expressed as an hourly rate, the contractor shall either pay the benefit as stated in the wage determination or shall pay another bona fide fringe benefit or an hourly cash equivalent thereof.
 - (iv)** If the contractor does not make payments to a trustee or other third persons, the contractor may consider as part of the wages of any laborer or mechanic the amount of any costs reasonably anticipated in providing bona fide fringe benefits under a plan or program, provided that the Secretary of Labor has found, upon written request of the contractor, that the applicable standards of the Davis-Bacon have been met. The Secretary of Labor may require the contractor to set aside in a separate account assets for the meeting of obligations under the plan or program. (Approved by the Office of Management and Budget under OMB Control Number 1215-0140.)
- A.2. Withholding.** HUD and its designee shall upon its own action or upon written request of an authorized representative of the Department of Labor withhold or cause to be withheld from the contractor under this contract or any other Federal contract with the same prime contractor, or any other Federally-assisted contract subject to Davis-Bacon prevailing wage requirements, which is held by the same prime contractor so much of the accrued payments or advances as may be considered necessary to pay laborers and mechanics, including apprentices, trainees and helpers, employed by the contractor or any subcontractor the full amount of wages required by the contract. In the event of failure to pay any laborer or mechanic, including any apprentice, trainee or helper, employed or working on the site of the work (or under the United States Housing Act of 1937 or under the Housing Act of 1949 in the construction or development of the project), all or part of the wages required by the contract, HUD or its designee may, after written notice to the contractor, sponsor, applicant, or owner, take such action as may be necessary to cause the suspension of any further payment, advance, or guarantee of funds until such violations have ceased. HUD or its designee may, after written notice to the contractor, disburse such amounts withheld for an on account of the contractor or subcontractor to the respective employees to whom they are due. The Comptroller General shall make such disbursements in the case of direct Davis-Bacon Act contracts.
- A.3.(i) Payrolls and Basic Records.** Payrolls and basic records relating thereto shall be maintained by the contractor during the course of the work preserved for a period of three years thereafter for all laborers and mechanics working at the site of the work (or under the United States Housing Act of

Construction Bid Package

1937, or under the Housing Act of 1949, in the construction or development of the project). Such records shall contain the name, address, and social security number of each such worker, his or her correct classification, hourly rates of wages paid (including rates of contributions or costs anticipated for bona fide fringe benefits or cash equivalents thereof of the types described in Section 1(b)(2)(B) of the Davis-Bacon Act), daily and weekly number of hours worked, deductions made and actual wages paid. Whenever the Secretary of Labor has found under 29 CFR 5.5(a)(1)(iv) that the wages of any laborer or mechanic include the amount of any costs reasonably anticipated in providing benefits under a plan or program described in Section 1(b)(2)(B) of the Davis-Bacon Act, the contractor shall maintain records which show that the commitment to provide such benefits is enforceable, that the plan or program is financially responsible, and that the plan or program has been communicated in writing to the laborers or mechanics affected, and records which show the costs anticipated or the actual cost incurred in providing such benefits. Contractors employing apprentices or trainees under approved programs shall maintain written evidence of the registration of apprenticeship programs and certification of trainee programs, the registration of the apprentices and trainees, and the ratios and wage rates prescribed in the applicable programs. (Approved by the Office of Management and Budget under OMB Control Numbers 1215-0140 and 1215-0017.)

- (ii)(a)** The contractor shall submit weekly for each week in which any contract work is performed a copy of all payrolls to HUD or its designee if the agency is a party to the contract, but if the agency is not such a party, the contractor will submit the payrolls to the applicant, sponsor, or owner, as the case may be, for transmission to HUD or its designee. The payrolls submitted shall set out accurately and completely all of the information required to be maintained under 29 CFR Part 5.5(a)(3)(i). This information may be submitted in any form desired. Optional Form WH-347 is available for this purpose and may be purchased from the Superintendent of Documents (Federal Stock Number 029-005-00014-1), U.S. Government Printing Office, Washington, D.C. 20402. The prime contractor is responsible for the submission of copies of payrolls by all subcontractors. (Approved by the Office of Management and Budget under OMB Control Number 1215-0149.)
- (ii)(b)** Each payroll submitted shall be accompanied by a "Statement of Compliance," signed by the contractor or subcontractor or his or her agent who pays or supervises the payment of the persons employed under the contract and shall certify the following:

 - (1) That the payroll for the payroll period contains the information required to be maintained under 29 CFR Part 5.5(a)(3)(i) and that such information is correct and complete;
 - (2) That each laborer or mechanic (including each helper, apprentice, and trainee) employed on the contract during the payroll period has been paid the full weekly wages earned, without rebate, either directly or indirectly, and that no deductions have been made either directly or indirectly from the full wages earned, other than permissible deductions as set forth in 29 CFR Part 3;
 - (3) That each laborer or mechanic has been paid not less than the applicable wage rates and fringe benefits or cash equivalents for the classification of work performed, as specified in the applicable wage determination incorporated into the contract.
- (ii)(c)** The weekly submission of a properly executed certification set forth on the reverse side of Optional Form WH-347 shall satisfy the requirement for submission of the "Statement of Compliance" required by paragraph A.3.(ii)(b) of this section.
- (ii)(d)** The falsification of any of the above certifications may subject the contractor or subcontractor to civil or criminal prosecution under Section 1001 of Title 18 and Section 231 of Title 31 of the United States Code.

Construction Bid Package

- (iii) The contractor or subcontractor shall make the records required under paragraph A.3.(i) of this section available for inspection, copying, or transcription by authorized representatives of HUD or its designee or the Department of Labor, and shall permit such representatives to interview employees during working hours on the job. If the contractor or subcontractor fails to submit the required records or to make them available, HUD or its designee may, after written notice to the contractor, sponsor, applicant, or owner, take such action as may be necessary to cause the suspension of any further payment, advance, or guarantee of funds. Furthermore, failure to submit the required records upon request or to make such records available may be grounds for debarment action pursuant to 29 CFR Part 5.12.
- 4.(i) Apprentices and Trainees.** Apprentices will be permitted to work at less than the predetermined rate for the work they performed when they are employed pursuant to and individually registered in a bona fide apprenticeship program registered with the U.S. Department of Labor, Employment and Training Administration, Bureau of Apprenticeship and Training, or with a State Apprenticeship Agency recognized by the Bureau, or if a person is employed in his or her first 90 days of probationary employment as an apprentice in such an apprenticeship program, who is not individually registered in the program, but who has been certified by the Bureau of Apprenticeship and Training or a State Apprenticeship Agency (where appropriate) to be eligible for probationary employment as an apprentice. The allowable ration of apprentices to journeymen on the job site in any craft classification shall not be greater than the ration permitted to the contractor as to the entire work force under the registered program. Any worker listed on a payroll at an apprentice wage rate, who is not registered or otherwise employed as stated above, shall be paid not less than the applicable wage rate on the wage determination for the classification of work actually performed. In addition, any apprentice performing work on the job site in excess of the ratio permitted under the registered program shall be paid not less than the applicable wage rate on the wage determination for the work actually performed. Where a contractor is performing construction on a project in a locality other than that in which its program is registered, the ratios and wage rates (expressed in percentages of the journeyman's hourly rate) specified in the contractor's or subcontractor's registered program shall be observed. Every apprentice must be paid at not less than the rate specified in the registered program for the apprentice's level of progress, expressed as a percentage of the journeymen hourly rate specified in the applicable wage determination. Apprentices shall be paid fringe benefits in accordance with the provisions of the apprenticeship program. If the apprenticeship program does not specify fringe benefits, apprentices must be paid the full amount of fringe benefits listed on the wage determination for the applicable classification. If the Administrator determines that a different practice prevails for the applicable apprentice classification, fringes shall be paid in accordance with that determination. In the event the Bureau of Apprenticeship and Training, or a State Apprenticeship Agency recognized by the Bureau, withdraws approval of an apprenticeship program, the contractor will no longer be permitted to utilize apprentices at less than the applicable predetermined rate for the work performed until an acceptable program is approved.
- 4.(ii) Trainees.** Except as provided in 29 CFR 5.16, trainees will not be permitted to work at less than the predetermined rate for the work performed unless they are employed pursuant to and individually registered in a program which has received prior approval, evidence by formal certification by the U.S. Department of Labor, Employment and Training Administration. The ratio of trainees to journeymen on the job site shall not be greater than permitted under the plan approved by the Employment and Training Administration. Every trainee must be paid at not less than the rate specified in the approved program for the trainee's level of progress, expressed as a percentage of the journeyman hourly rate specified in the applicable wage determination. Trainees shall be paid fringe benefits in accordance with the provisions of the trainee program. If the trainee program does not mention fringe benefits, trainees shall be paid the full amount of fringe benefits listed on the wage determination unless the Administrator of the Wage and Hours

Construction Bid Package

Division determines that there is an apprenticeship program associated with the corresponding journeyman wage rate on the wage determination which provides for less than full fringe benefits for apprentices. Any employee listed on the payroll at a trainee rate who is not registered and participating in a training plan approved by the Employment and Training Administration shall be paid not less than the applicable wage rate on the wage determination for the work actually performed. In addition, any trainee performing work on the job site in excess of the ratio permitted under the registered program shall be paid not less than the applicable wage rate on the wage determination for the work actually performed. In the event the Employment and Training Administration withdraws approval of a training program, the contractor will no longer be permitted to utilize trainees at less than the applicable predetermined rate for the work performed until an acceptable program is approved.

- 4.(iii) Equal Employment Opportunity.** The Utilization of apprentices, trainees and journeymen under this part shall be in conformity with the equal employment opportunity requirements of Executive Order 11246, as amended and 29 CFR part 30.
- 5. Compliance with Copeland Act requirements.** The contractor shall comply with the requirements of 29 CFR Part 3 which are incorporated by reference in this contract.
- 6. Subcontracts.** The contractor or subcontractor will insert in any subcontracts the clauses contained in 29 CFR 5.5(a)(1) through (10) and such other clauses as HUD or its designee may be appropriate instruction require, and also a clause requiring the subcontractors to include these clauses in any lower tier subcontracts. The prime contractor shall be responsible for the compliance by any subcontractor or lower tier subcontractor with all the contract clauses in 29 CFR Part 5.5.
- 7. Contractor termination; debarment.** A breach of the contract clauses in 29 CFR 5.5 may be grounds for termination of the contract, and for debarment as a contractor and a subcontractor as provided in 29 CFR 5.12.
- 8. Compliance with Davis-Bacon and Related Act Requirements.** All rulings and interpretations of the Davis-Bacon and Related Acts contained in 29 CFR Parts 1,3, and 5 are herein incorporated by reference in this contract.
- 9. Disputes concerning labor standards.** Disputes arising out of the labor standards provisions of this contract shall not be subject to the general disputes clause of this contract. Such disputes shall be resolved in accordance with the procedures of the Department of Labor set forth in 29 CFR Parts 5,6, and 7. Disputes within the meaning of this clause include disputes between the contractor (or any of its subcontractors) and HUD or its designee, the U.S. Department of Labor, or the employees or their representatives.
- 10.(i) Certification of Eligibility.** By entering into this contract, the contractor certifies that neither it (nor he or she) nor any person or firm who has an interest in the contractor's firm is a person or firm ineligible to be awarded Government contracts by virtue of Section 3(a) of the Davis-Bacon Act or 29 CFR 5.12(a)(1) or to be awarded HUD contracts or participate in HUD programs pursuant to 24 CFR Part 24.
- 10.(ii)** No part of this contract shall be subcontracted to any person or firm ineligible for award of a Government contract by virtue of Section 3(a) of the Davis-Bacon Act or 29 CFR 5.12(a)(1) or to be awarded HUD contracts or participate in HUD programs pursuant to 24 CFR Part 24.
- 10.(iii)** The penalty for making false statements is prescribed in the U.S. Criminal Code, 18 U.S.C. 1001. Additionally, U.S. Criminal Code Section 1010, Title 18, U.S.C., "Federal Housing Administration

Construction Bid Package

transactions", provides in part "Whoever, for the purpose of... influencing in any way the action of such Administration ... makes, utters or publishes any statement, knowing the same to be false ... shall be fined not more than \$5,000 or imprisoned not more than two years, or both."

- 11. Complaints, Proceedings, or Testimony by Employees.** No laborer or mechanic to whom the wages, salary or other labor standards provisions of this contract are applicable shall be discharged or in any other manner discriminated against by the Contractor or any subcontractor because such employee has filed any complaint or instituted or caused to be instituted any proceeding or has testified or is about to testify in any proceeding under or relating to the labor standards applicable under this Contract to his employer.
- B. Contract Work Hours and Safety Standards Act.** As used in this paragraph, the terms "laborers" and "mechanics" include watchmen and guards.
 - (1) Overtime requirements.** No contractor or subcontractor contracting for any part of the contract work which may require or involve the employment of laborers or mechanics shall require or permit any such laborer or mechanic in any workweek in which he or she is employed on such work to work in excess of forty hours in such workweek unless such laborer or mechanic receives compensation at a rate not less than one and one-half times the basic rate of pay for all hours worked in excess of forty hours in such workweek.
 - (2) Violation; liability for unpaid wages; liquidated damages.** In the event of any violation of the clause set forth in subparagraph (1) of this paragraph, the contractor and any subcontractor responsible therefor shall be liable for the unpaid wages. In addition, such contractor and subcontractor shall be liable to the United States (in the case of work done under contract for the District of Columbia or a territory, to such District or to such territory), for liquidated damages. Such liquidated damages shall be computed with respect to each individual laborer or mechanic, including watchmen and guards, employed in violation of the clause set forth in subparagraph (1) of this paragraph, in the sum of \$10 for each calendar day on which such individual was required or permitted to work in excess of the standard workweek of forty hours without payment of the overtime wages required by the clause set forth in subparagraph (1) of this paragraph.
 - (3) Withholding for unpaid wages and liquidated damages.** HUD or its designee shall upon its own action or upon written request of an authorized representative of the Department of Labor withhold or cause to be withheld, from any monies payable on account of work performed by the contractor or subcontractor under any such contract or any other Federal contract with the same prime contract, or any other Federally-assisted contract subject to the Contract Work Hours and Safety Standards Act, which is held by the same prime contractor such sums as may be determined to be necessary to satisfy any liabilities of such contractor or subcontractor for unpaid wages and liquidated damages as provided in the clause set forth in subparagraph (2) of this paragraph.
 - (4) Subcontracts.** The contractor or subcontractor shall insert in any subcontracts the clauses set forth in subparagraph (1) through (4) of this paragraph and also a clause requiring the subcontractors to include these clauses in any lower tier subcontracts. The prime contractor shall be responsible for compliance by any subcontractor or lower tier subcontractor with the clauses set forth in subparagraphs (1) through (4) of this paragraph.
- C. Health and Safety**
 - (1)** No laborer or mechanic shall be required to work in surroundings or under working conditions which are unsanitary, hazardous, or dangerous to his health and safety as determined under construction safety and health standards promulgated by the Secretary of Labor regulation.

Construction Bid Package

- (2)** The Contractor shall comply with all regulations issued by the Secretary of Labor pursuant to Title 29 Part 1926 (formerly part 1518) and failure to comply may result in imposition of sanctions pursuant to the Contract Work Hours and Safety Standards Act (Public Law 91-54, 83 Stat 96).
- (3)** The Contractor shall include the provisions of this Article in every subcontract so that such provisions will be binding on each subcontractor. The Contractor shall take such action with respect to any subcontract as the Secretary of Housing and Urban Development or the Secretary of Labor shall direct as a means of enforcing such provisions.

Construction Bid Package

COMMUNITY DEVELOPMENT BLOCK GRANT PROGRAM

CONTRACTOR'S CERTIFICATION

CONCERNING LABOR STANDARDS AND PREVAILING WAGE REQUIREMENTS

To:	Date:
c/o:	Project Number:
	Project Name:

1. The undersigned, having executed a contract with _____ for the construction of the above-identified project, acknowledges that:

- (a) The Labor Standards provisions are included in the aforesaid contract;
- (b) Correction of any infractions of the aforesaid conditions, including infractions by any of his subcontractors and any lower tier subcontractors, is his responsibility.

2. He certifies that:

- (a) Neither he nor any firm, partnership or association in which he has substantial interest is designated as an ineligible contractor by the Comptroller General of the United States pursuant to Section 5.6(b) of the Regulations of the Secretary of Labor, Part 5 (29 CFR Part 5) or pursuant to Section 3(a) of the Davis-Bacon Act, as amended [40 U.S.C. 275a-2(a)].
- (b) No part of the aforementioned contract has been or will be subcontracted to any subcontractor if such subcontractor or any firm, corporation, partnership or association in which such subcontractor has a substantial interest is designed s an ineligible contractor pursuant to any of the aforementioned regulatory or statutory provisions.

3. He agrees to obtain and forward to the aforementioned recipient within ten days after the execution of any subcontract, including those executed by his subcontractors any lower tier subcontractors, a Subcontractor's Certification Concerning Labor Standards and Prevailing Wage Requirements executed by the subcontractors.

4. He certifies that:

- (a) The legal name and the business address of the undersigned is:

- (b) The undersigned is:

_____ (1) A single proprietorship

_____ (2) A corporation organized in the State of _____

Construction Bid Package

- _____ (3) A partnership
- _____ (4) Other Organization (Describe):

(c) The name, title and address of the owner, partners or officers of the undersigned are:

Name	Title	Address
_____	_____	_____
_____	_____	_____
_____	_____	_____
_____	_____	_____

(d) The names and addresses of all other persons, both natural and corporate, having a substantial interest in the undersigned, and the nature of the interest are: (If none, so state):

Name	Address	Nature of Interest
_____	_____	_____
_____	_____	_____
_____	_____	_____
_____	_____	_____

(e) The names, addresses and trade classifications of all other building construction contractors in which the undersigned has a substantial interest are: (If none, so state):

Contractor	_____
Signature	_____
Date	_____

WARNING

U.S. CRIMINAL CODE, Section 1010, Title 18, U.S.C., provides in part: "Whoever ... makes, passes, utters or publishes any statement, knowing the same to be false ... shall be fined not more than \$5,000 or imprisoned not more than two years, or both."

COMMUNITY DEVELOPMENT BLOCK GRANT PROGRAM

SUBCONTRACTOR'S CERTIFICATION

CONCERNING LABOR STANDARDS AND PREVAILING WAGE REQUIREMENTS

To:	Date:
c/o:	Project Number:
	Project Name:

1. The undersigned, having executed a contract with _____ for the construction of the above-identified project, acknowledges that:

- (a) The Labor Standards provisions are included in the aforesaid contract;
- (b) Correction of any infractions of the aforesaid conditions, including infractions by any of his subcontractors and any lower tier subcontractors, is his responsibility.

2. He certifies that:

- (a) Neither he nor any firm, partnership or association in which he has substantial interest is designated as an ineligible contractor by the Comptroller General of the United States pursuant to Section 5.6(b) of the Regulations of the Secretary of Labor, Part 5 (29 CFR Part 5) or pursuant to Section 3(a) of the Davis-Bacon Act, as amended [40 U.S.C. 275a-2(a)].
- (b) No part of the aforementioned contract has been or will be subcontracted to any subcontractor if such subcontractor or any firm, corporation, partnership or association in which such subcontractor has a substantial interest is designed s an ineligible contractor pursuant to any of the aforementioned regulatory or statutory provisions.

3. He agrees to obtain and forward to the aforementioned recipient within ten days after the execution of any subcontract, including those executed by his subcontractors any lower tier subcontractors, a Subcontractor's Certification Concerning Labor Standards and Prevailing Wage Requirements executed by the subcontractors.

4. He certifies that:

- (a) The legal name and the business address of the undersigned is:

(b) The undersigned is:

_____ (1) A single proprietorship

Construction Bid Package

- _____ (2) A corporation organized in the State of _____
- _____ (3) A partnership
- _____ (4) Other Organization (Describe):

(c) The name, title and address of the owner, partners or officers of the undersigned are:

Name	Title	Address
_____	_____	_____
_____	_____	_____
_____	_____	_____
_____	_____	_____

(d) The names and addresses of all other persons, both natural and corporate, having a substantial interest in the undersigned, and the nature of the interest are: (If none, so state):

Name	Address	Nature of Interest
_____	_____	_____
_____	_____	_____
_____	_____	_____
_____	_____	_____

(e) The names, addresses and trade classifications of all other building construction contractors in which the undersigned has a substantial interest are: (If none, so state):

SubContractor	_____
Signature	_____
Date	_____

WARNING

U.S. CRIMINAL CODE, Section 1010, Title 18, U.S.C., provides in part: "Whoever ... makes, passes, utters or publishes any statement, knowing the same to be false ... shall be fined not more than \$5,000 or imprisoned not more than two years, or both."

Construction Bid Package

Certificate of Compliance With Federal Labor Standards Provisions

I, the undersigned _____
the duly authorized representative of _____
(hereinafter referred to as the contractor), do hereby certify that I have examined the Federal Labor Standards Provisions (HUD-4010) with related certificates and documents, and all of the conditions surrounding these provisions including, but not limited to the following:

1. The contractor is responsible for employing only eligible subcontractors who have certified eligibility in written contracts containing Federal Labor Standards Provisions.
2. The contractor is responsible for the payment of federal prevailing wage rates by its subcontractors while performing work under this contract. If the subcontractor fails to pay the prevailing wages as specified in this contract, the prime contractor may be required to make appropriate restitution to the underpaid workers.
3. The contractor is responsible for collecting weekly certified payrolls from its subcontractors, review said payrolls for compliance with the federal wage rates, and forward same to the local government contract authority.
4. The contractor also understands that only those classifications listed in the original bid documents are applicable to this job, and no special classifications may be incorporated after the contract award.

The prime contractor hereby agrees to perform all of its responsibilities in conformance with the Federal Labor Standards Provisions both diligently and affectively.

BY: _____

TITLE: _____

DATE: _____

Construction Bid Package

**AFFIDAVIT IN COMPLIANCE WITH SECTION 3517.13
OF THE OHIO REVISED CODE**

STATE OF OHIO

COUNTY OF _____

Personally appeared before me the undersigned, as an individual or as a representative of _____ or a contract for _____ to be let by the County of Seneca, who, being duly cautioned and sworn, makes the following statement with respect to prohibited activities constituting a conflict of interest or other violations under Ohio Revised Code Section 3517.13, and further states that the undersigned has the authority to make the following representation on behalf of himself or herself or of the business entity:

1. That none of the following has **individually** made after April 4, 2007, and that, if awarded a contract for the purchase of goods or services with a cost aggregating more than \$10,000 in a calendar year, none of the following **individually** will make, beginning on the date the contract is awarded and extending until one year following the conclusion of the contract, as an individual, one or more campaign contributions totaling in excess of \$1,000, to any member of the _____ County Board of Commissioners or their individual campaign committees:

- a. myself (if applicable);
- b. any partner or owner or shareholder of the partnership (if applicable);
- c. any owner of more than 20% of the corporation or business trust (if applicable);
- d. each spouse of any person identified in (a) through (c) of this section;
- e. each child seven years of age to seventeen years of age of any person identified in divisions (a) through (c) of this section (only applicable to contributions made on or after January 1, 2007).

2. That none of the following have **collectively** made after April 4, 2007, and that, if awarded a contract for the purchase of goods or services with a cost aggregating more than \$10,000 in a calendar year, none of the following **collectively** will make, beginning on the date the contract is awarded and extending until one year following the conclusion of the contract, one or more campaign contributions totaling in excess of \$2,000, to any member of the _____ County Board of Commissioners or their individual campaign committees:

- a. myself (if applicable);
- b. any partner or owner or shareholder of the partnership (if applicable);
- c. any owner of more than 20% of the corporation or business trust (if applicable);
- d. each Spouse of any person identified in (a) through (c) of this section;
- e. each child seven years of age to seventeen years of age of any person identified in divisions (a) through (c) of this section;
- f. any political action committee affiliated with any person identified in divisions (a) through (c) of this section.

Signature _____

Title: _____

Sworn to before me and subscribed in my presence this _____ day of _____, 2022.

Notary Public _____

My Commission Expires: _____

**FEDERAL DAVIS- BACON WAGE DECISION
SECTION G-15**

"General Decision Number: OH20220001 04/08/2022

Superseded General Decision Number: OH20210001

State: Ohio

Construction Types: Heavy and Highway

Counties: Ohio Statewide.

Heavy and Highway Construction Projects

Note: Contracts subject to the Davis-Bacon Act are generally required to pay at least the applicable minimum wage rate required under Executive Order 14026 or Executive Order 13658. Please note that these Executive Orders apply to covered contracts entered into by the federal government that are subject to the Davis-Bacon Act itself, but do not apply to contracts subject only to the Davis-Bacon Related Acts, including those set forth at 29 CFR 5.1(a)(2)-(60).

<p>If the contract is entered into on or after January 30, 2022, or the contract is renewed or extended (e.g., an option is exercised) on or after January 30, 2022:</p>	<p>. Executive Order 14026 generally applies to the contract.</p> <p>. The contractor must pay all covered workers at least \$15.00 per hour (or the applicable wage rate listed on this wage determination, if it is higher) for all hours spent performing on the contract in 2022.</p>
<p>If the contract was awarded on or between January 1, 2015 and January 29, 2022, and the contract is not renewed or extended on or after January 30, 2022:</p>	<p>. Executive Order 13658 generally applies to the contract.</p> <p>. The contractor must pay all covered workers at least \$11.25 per hour (or the applicable wage rate listed on this wage determination, if it is higher) for all hours spent performing on that contract in 2022.</p>

The applicable Executive Order minimum wage rate will be adjusted annually. If this contract is covered by one of the Executive Orders and a classification considered necessary for performance of work on the contract does not appear on this wage determination, the contractor must still submit a conformance request.

Additional information on contractor requirements and worker protections under the Executive Orders is available at <https://www.dol.gov/agencies/whd/government-contracts>.

Modification Number	Publication Date
0	01/07/2022
1	01/14/2022
2	01/28/2022

3	02/18/2022
4	02/25/2022
5	03/11/2022
6	04/08/2022

BROH0001-001 06/01/2021

DEFIANCE, FULTON (Excluding Fulton, Amboy & Swan Creek Townships), HENRY (Excluding Monroe, Bartlow, Liberty, Washington, Richfield, Marion, Damascus & Townships & that part of Harrison Township outside corporate limits of city of Napoleon), PAULDING, PUTNAM and WILLIAMS COUNTIES

	Rates	Fringes
Bricklayer, Stonemason.....	\$ 30.40	17.55

BROH0001-004 06/01/2021

	Rates	Fringes
CEMENT MASON/CONCRETE FINISHER...	\$ 30.40	17.55

BROH0003-002 06/01/2021

FULTON (Townships of Amboy, Swan Creek & Fulton), HENRY (Townships of Washington, Damascus, Richfield, Bartlow, Liberty, Harrison, Monroe, & Marion), LUCAS and WOOD (Townships of Perrysburg, Ross, Lake, Troy, Freedom, Montgomery, Webster, Center, Portage, Middleton, Plain, Liberty, Henry, Washington, Weston, Milton, Jackson & Grand Rapids) COUNTIES

	Rates	Fringes
Bricklayer, Stonemason.....	\$ 30.40	17.55

BROH0005-003 06/01/2020

CUYAHOGA, LORAIN & MEDINA (Hinckley, Granger, Brunswick, Liverpool, Montville, York, Homer, Harrisville, Chatham, Litchfield & Spencer Townships and the city of Medina)

	Rates	Fringes
BRICKLAYER		
BRICKLAYERS; CAULKERS;		
CLEANERS; POINTERS; &		
STONEMASONS.....	\$ 36.64	17.13
SANDBLASTERS.....	\$ 36.39	17.13
SEWER BRICKLAYERS & STACK		
BUILDERS.....	\$ 36.64	17.13
SWING SCAFFOLDS.....	\$ 37.14	17.13

BROH0006-005 06/01/2021

CARROLL, COLUMBIANA (Knox, Butler, West & Hanover Townships), STARK & TUSCARAWAS

	Rates	Fringes
Bricklayer, Stonemason.....	\$ 30.40	17.55

BROH0007-002 06/01/2021

LAWRENCE

	Rates	Fringes
Bricklayer, Stonemason.....	\$ 30.40	17.55

BROH0007-005 06/01/2021

PORTAGE & SUMMIT

	Rates	Fringes
BRICKLAYER.....	\$ 30.40	17.55

BROH0007-010 06/01/2017

PORTAGE & SUMMIT

	Rates	Fringes
MASON - STONE.....	\$ 28.65	14.55

BROH0008-001 06/01/2021

COLUMBIANA (Salem, Perry, Fairfield, Center, Elk Run, Middleton, & Unity Townships and the city of New Waterford), MAHONING & TRUMBULL

	Rates	Fringes
BRICKLAYER.....	\$ 30.40	17.55

BROH0009-002 06/01/2021

BELMONT & MONROE COUNTIES and the Townships of Warren & Mt. Pleasant and the Village of Dillonvale in JEFFERSON COUNTY

	Rates	Fringes
Bricklayer, Stonemason.....	\$ 30.40	17.55
Refractory.....	\$ 31.45	19.01

BROH0010-002 06/01/2021

COLUMBIANA (St. Clair, Madison, Wayne, Franklin, Washington, Yellow Creek & Liverpool Townships) & JEFFERSON (Brush Creek & Saline Townships)

	Rates	Fringes
Bricklayer, Stonemason.....	\$ 30.40	17.55

BROH0014-002 06/01/2021

HARRISON & JEFFERSON (Except Mt. Pleasant, Warren, Brush Creek, Saline & Salineville Townships & the Village of Dillonvale)

	Rates	Fringes
--	-------	---------

Bricklayer, Stonemason.....\$ 30.40 17.55

 BROH0016-002 06/01/2021

ASHTABULA, GEAUGA, and LAKE COUNTIES

	Rates	Fringes
Bricklayer, Stonemason.....	\$ 30.40	17.55

BROH0018-002 06/01/2021		

BROWN, BUTLER, CLERMONT, HAMILTON, PREBLE (Gasper, Dixon, Israel, Lanier, Somers & Gratis Townships) & WARREN COUNTIES:

	Rates	Fringes
Bricklayer, Stonemason.....	\$ 30.40	17.55

BROH0022-004 06/01/2021		

CHAMPAIGN, CLARK, CLINTON, DARKE, GREENE, HIGHLAND, LOGAN, MIAMI, MONTGOMERY, PREBLE (Jackson, Monroe, Harrison, Twin, Jefferson & Washington Townships) and SHELBY COUNTIES

	Rates	Fringes
Bricklayer, Stonemason.....	\$ 30.40	17.55

BROH0032-001 06/01/2021		

GALLIA & MEIGS

	Rates	Fringes
Bricklayer, Stonemason.....	\$ 30.40	17.55

BROH0035-002 06/01/2021		

ALLEN, AUGLAIZE, MERCER and VAN WERT COUNTIES

	Rates	Fringes
Bricklayer, Stonemason.....	\$ 30.40	17.55

BROH0039-002 06/01/2021		

ADAMS & SCIOTO

	Rates	Fringes
Bricklayer, Stonemason.....	\$ 30.40	17.55

BROH0040-003 06/01/2021		

ASHLAND, CRAWFORD, HARDIN, HOLMES, MARION, MORROW, RICHLAND, WAYNE and WYANDOT (Except Crawford, Ridge, Richland & Tymochtee Townships) COUNTIES

	Rates	Fringes
--	-------	---------

Bricklayer, Stonemason.....\$ 31.93 22.54

FOOTNOTE: Layout Man and Sawman rate: \$1.00 per hour above journeyman rate.

Free standing stack work ground level to top of stack; Sandblasting and laying of carbon masonry material in swing stage and/or scaffold; Ramming and spading of plastics and gunniting: \$1.50 per hour above journeyman rate.

""Hot"" work: \$2.50 above journeyman rate.

BROH0044-002 06/01/2021

Rates Fringes

Bricklayer, Stonemason
COSHOCOTON, FAIRFIELD,
GUERNSEY, HOCKING, KNOX,
KICKING, MORGAN,
MUSKINGUM, NOBLE (Beaver,
Buffalo, Seneca & Wayne
Townships) & PERRY
COUNTIES:.....\$ 30.40 17.55

BROH0045-002 06/01/2021

FAYETTE, JACKSON, PIKE, ROSS and VINTON COUNTIES

Rates Fringes

Bricklayer, Stonemason.....\$ 30.40 17.66

BROH0046-002 06/01/2021

ERIE, HANCOCK, HURON, OTTAWA, SANDUSKY, SENECA, WOOD (Perry & Bloom Townships) and WYANDOT (Tymochtee, Crawford, Ridge & Richland Townships) COUNTIES & the Islands of Lake Erie north of Sandusky

Rates Fringes

Bricklayer, Stonemason.....\$ 30.40 17.55

FOOTNOTE: Layout Man and Sawman rate: \$1.00 per hour above journeyman rate.

Free standing stack work ground level to top of stack; Sandblasting and laying of carbon masonry material in swing stage and/or scaffold; Ramming and spading of plastics and gunniting: \$1.50 per hour above journeyman rate.

""Hot"" work: \$2.50 above journeyman rate.

BROH0052-001 06/01/2021

ATHENS COUNTY

Rates Fringes

Bricklayer, Stonemason.....\$ 30.40 17.55

BROH0052-003 06/01/2021

NOBLE (Brookfield, Noble, Center, Sharon, Olive, Enoch, Stock, Jackson, Jefferson & Elk Townships) and WASHINGTON COUNTIES

	Rates	Fringes
Bricklayer, Stonemason.....	\$ 30.40	17.55

BROH0055-003 06/01/2021		

DELAWARE, FRANKLIN, MADISON, PICKAWAY and UNION COUNTIES

	Rates	Fringes
Bricklayer, Stonemason.....	\$ 30.40	17.55

CARP0003-004 05/01/2017		

MAHONING & TRUMBULL

	Rates	Fringes
CARPENTER.....	\$ 26.20	17.42

CARP0069-003 05/01/2017		

CARROLL, STARK, TUSCARAWAS & WAYNE

	Rates	Fringes
CARPENTER.....	\$ 25.98	15.98

CARP0069-006 05/01/2017		

COSHOCTON, HOLMES, KNOX & MORROW

	Rates	Fringes
CARPENTER.....	\$ 24.04	15.29

CARP0171-002 05/01/2019		

BELMONT, COLUMBIANA, HARRISON, JEFFERSON & MONROE

	Rates	Fringes
CARPENTER.....	\$ 27.37	20.02

CARP0200-002 05/01/2021		

ADAMS, ATHENS, DELAWARE, FAIRFIELD, FAYETTE, FRANKLIN, GALLIA, GUERNSEY, HIGHLAND, HOCKING, JACKSON, LAWRENCE, LICKING, MADISON, MARION, MEIGS, MORGAN, MUSKINGUM, NOBLE, PERRY, PICKAWAY, PIKE, ROSS, SCIOTO, UNION, VINTON and WASHINGTON COUNTIES

	Rates	Fringes
CARPENTER.....	\$ 30.28	20.08
Diver.....	\$ 39.41	10.40
PILEDRIVERMAN.....	\$ 30.28	20.08

CARP0248-005 07/01/2008		

LUCAS & WOOD

	Rates	Fringes
CARPENTER.....	\$ 27.27	14.58

CARP0248-008 07/01/2008		

	Rates	Fringes
CARPENTER DEFIANCE, FULTON, HANCOCK, HENRY, PAULDING & WILLIAMS COUNTIES.....	\$ 23.71	13.28

CARP0254-002 05/01/2017		

ASHTABULA, CUYAHOGA, GEAUGA & LAKE

	Rates	Fringes
CARPENTER.....	\$ 32.40	16.97

CARP0372-002 05/01/2016		

ALLEN, AUGLAIZE, HARDIN, MERCER, PUTNAM & VAN WERT

	Rates	Fringes
CARPENTER.....	\$ 24.54	18.21

CARP0639-003 05/01/2017		

MEDINA, PORTAGE & SUMMIT

	Rates	Fringes
CARPENTER.....	\$ 30.42	16.99

CARP0735-002 05/01/2019		

ASHLAND, ERIE, HURON, LORAIN & RICHLAND

	Rates	Fringes
CARPENTER.....	\$ 26.30	17.91

CARP1311-001 05/01/2017		

BROWN, BUTLER, CHAMPAIGN, CLARK, CLERMONT, CLINTON, DARKE,
GREENE, HAMILTON, LOGAN, MIAMI, MONTGOMERY, PREBLE, SHELBY &
WARREN

	Rates	Fringes
Carpenter & Piledrivermen.....	\$ 29.34	15.95
Diver.....	\$ 40.58	9.69

CARP1393-002 07/01/2008		

CRAWFORD, DEFIANCE, FULTON, HANCOCK, HENRY, LUCAS, OTTAWA,
PAULDING, SANDUSKY, SENECA, WILLIAMS & WOOD

	Rates	Fringes
--	-------	---------

Piledrivermen & Diver's Tender...\$ 27.30 16.05

DIVERS - \$250.00 per day

 CARP1393-003 07/01/2008

ALLEN, AUGLAIZE, HARDIN, MERCER, PUTNAM, VAN WERT & WYANDOT

Rates Fringes

Piledrivermen & Diver's Tender...\$ 25.15 15.92

DIVERS - \$250.00 per day

 CARP1871-006 05/01/2017

BELMONT, HARRISON, & MONROE

Rates Fringes

Diver, Wet.....\$ 48.11 17.33

Piledrivermen; Diver, Dry.....\$ 32.07 17.33

 CARP1871-008 05/01/2017

ASHLAND, ASHTABULA, CUYAHOGA, ERIE, GEAUGA, HURON, LAKE,
 LORAIN, MEDINA, PORTAGE, RICHLAND & SUMMIT

Rates Fringes

Diver, Wet.....\$ 45.80 18.84

Piledrivermen; Diver, Dry.....\$ 30.53 18.84

 CARP1871-014 05/01/2017

CARROLL, STARK, TUSCARAWAS & WAYNE

Rates Fringes

Diver, Wet.....\$ 38.34 16.95

Piledrivermen; Diver, Dry.....\$ 25.56 16.95

 CARP1871-015 05/01/2017

COSHOCTON, HOLMES, KNOX & MORROW

Rates Fringes

Diver, Wet.....\$ 37.34 16.07

Piledrivermen; Diver, Dry.....\$ 24.89 16.07

 CARP1871-017 05/01/2017

MAHONING & TRUMBULL

Rates Fringes

Diver, Wet.....\$ 40.65 17.62

Piledrivermen; Diver, Dry.....\$ 27.10 17.62

 CARP2235-012 01/01/2014

COLUMBIANA & JEFFERSON

	Rates	Fringes
PILEDRIVERMAN.....	\$ 31.74	16.41

CARP2239-001 07/01/2008		

CRAWFORD, OTTAWA, SANDUSKY, SENECA & WYANDOT

	Rates	Fringes
CARPENTER.....	\$ 23.71	13.28

ELEC0008-002 05/24/2021		

DEFIANCE, FULTON, HANCOCK, HENRY, LUCAS, OTTAWA, PAULDING, PUTNAM, SANDUSKY, SENECA, WILLIAMS & WOOD

	Rates	Fringes
CABLE SPLICER.....	\$ 38.98	18.96
ELECTRICIAN.....	\$ 43.33	26.61

ELEC0032-003 12/06/2021		

ALLEN, AUGLAIZE, HARDIN, LOGAN, MERCER, SHELBY, VAN WERT & WYANDOT (Crawford, Jackson, Marseilles, Mifflin, Ridgeland, Ridge & Salem Townships)

	Rates	Fringes
ELECTRICIAN.....	\$ 33.22	19.73

ELEC0038-002 04/26/2021		

CUYAHOGA, GEAUGA (Bainbridge, Chester & Russell Townships) & LORAIN (Columbia Township)

	Rates	Fringes
ELECTRICIAN Excluding Sound & Communications Work.....	\$ 40.63	21.74

FOOTNOTES;

- a. 6 Paid Holidays: New Year's Day; Memorial Day; July 4th; Labor Day; Thanksgiving Day; & Christmas Day
- b. 1 week's paid vacation for 1 year's service; 2 weeks' paid vacation for 2 or more years' service

ELEC0038-008 04/26/2021		

CUYAHOGA, GEAUGA (Bainbridge, Chester & Russell Townships) & LORAIN (Columbia Township)

	Rates	Fringes
Sound & Communication Technician		
Communications Technician...	\$ 28.80	12.77
Installer Technician.....	\$ 27.55	12.77

FOOTNOTES;

- a. 6 Paid Holidays: New Year's Day; Memorial Day; July 4th; Labor Day; Thanksgiving Day; & Christmas Day
- b. 1 week's paid vacation for 1 year's service; 2 weeks' paid vacation for 2 or more years' service

ELEC0064-003 11/29/2021

COLUMBIANA (Butler, Fairfield, Perry, Salem & Unity Townships)
 MAHONING (Austintown, Beaver, Berlin, Boardman, Canfield, Ellsworth, Coitsville, Goshen, Green, Jackson, Poland, Springfield & Youngstown Townships), & TRUMBULL (Hubbard & Liberty Townships)

	Rates	Fringes
ELECTRICIAN.....	\$ 36.10	18.17

ELEC0071-001 01/01/2019

ASHLAND, CHAMPAIGN, CLARK, COSHOCTON, CRAWFORD, DELAWARE, FAIRFIELD, FAYETTE, FRANKLIN, GUERNSEY, HIGHLAND, HOCKING, JACKSON (Coal, Jackson, Liberty, Milton, Washington & Wellston Townships), KNOX, LICKING, MADISON, MARION, MONROE, MORGAN, MORROW, MUSKINGUM, NOBLE, PERRY, PICKAWAY, PIKE (Beaver, Benton, Jackson, Mifflin, Pebble, Peepee, Perry & Seal Townships), RICHLAND, ROSS, TUSCARAWAS (Auburn, Bucks, Clay, Jefferson, Oxford, Perry, Salem, Rush, Washington & York Townships), UNION, VINTON (Clinton, Eagle, Elk, Harrison, Jackson, Richland & Swan Townships), and WASHINGTON COUNTIES

	Rates	Fringes
Line Construction		
Equipment Operators.....	\$ 33.62	13.40
Groundmen.....	\$ 24.17	11.32
Linemen & Cable Splicers....	\$ 38.27	14.42

ELEC0071-004 01/01/2019

AUGLAIZE, CLINTON, DARKE, GREENE, LOGAN, MERCER, MIAMI, MONTGOMERY, PREBLE, and SHELBY COUNTIES

	Rates	Fringes
Line Construction		
Equipment Operator.....	\$ 33.62	13.40
Groundman.....	\$ 24.17	11.32
Lineman & Cable Splicers....	\$ 38.27	14.42

ELEC0071-005 12/31/2018

ASHTABULA, CUYAHOGA, GEAUGA, LAKE & LORAIN

	Rates	Fringes
LINE CONSTRUCTION: Equipment Operator		
DOT/Traffic Signal & Highway Lighting Projects...	\$ 32.44	14.10

Municipal Power/Transit Projects.....	\$ 40.10	16.42
LINE CONSTRUCTION: Groundman DOT/Traffic Signal & Highway Lighting Projects...	\$ 25.06	12.26
Municipal Power/Transit Projects.....	\$ 31.19	14.11
LINE CONSTRUCTION: Linemen/Cable Splicer DOT/Traffic Signal & Highway Lighting Projects...	\$ 36.13	15.03
Municipal Power/Transit Projects.....	\$ 44.56	17.58

ELEC0071-008 01/01/2019

COLUMBIANA, MAHONING, and TRUMBULL COUNTIES

	Rates	Fringes
Line Construction		
Equipment Operator.....	\$ 33.62	13.40
Groundman.....	\$ 24.17	11.32
Lineman & Cable Splicers....	\$ 38.27	14.42

ELEC0071-010 01/01/2019

BELMONT, CARROLL, HARRISON, HOLMES, JEFFERSON, MEDINA, PORTAGE,
STARK, SUMMIT, and WAYNE COUNTIES

	Rates	Fringes
Line Construction		
Equipment Operator.....	\$ 33.62	13.40
Groundman.....	\$ 24.17	11.32
Lineman & Cable Splicers....	\$ 38.27	14.42

ELEC0071-013 01/01/2019

BROWN, BUTLER, CLERMONT, HAMILTON, and WARREN COUNTIES

	Rates	Fringes
Line Construction		
Equipment Operator.....	\$ 33.62	13.40
Groundman.....	\$ 24.17	11.32
Lineman & Cable Splicers....	\$ 38.27	14.42

ELEC0071-014 01/01/2019

ADAMS, ATHENS, GALLIA, JACKSON (Bloomfield, Franklin, Hamilton,
Lick, Jefferson, Scioto & Madison Townships), LAWRENCE, MEIGS,
PIKE (Camp Creek, Marion, Newton, Scioto, Sunfish & Union
Townships), SCIOTO & VINTON (Brown, Knox, Madison, Vinton &
Wilkesville Townships)

	Rates	Fringes
Line Construction		
Equipment Operator.....	\$ 33.62	13.40
Groundman.....	\$ 24.17	11.32
Lineman & Cable Splicers....	\$ 38.27	14.42

ELEC0082-002 11/29/2021

CLINTON, DARKE, GREENE, MIAMI, MONTGOMERY, PREBLE & WARREN
(Wayne, Clear Creek & Franklin Townships)

	Rates	Fringes
ELECTRICIAN.....	\$ 33.25	20.84

* ELEC0082-006 11/29/2021

CLINTON, DARKE, GREENE, MIAMI, MONTGOMERY, PREBLE & WARREN
(Wayne, Clear Creek & Franklin Townships)

	Rates	Fringes
Sound & Communication Technician		
Cable Puller.....	\$ 12.98 **	3.89
Installer/Technician.....	\$ 25.95	12.27

* ELEC0129-003 02/28/2022

LORAIN (Except Columbia Township) & MEDINA (Litchfield & Liverpool Townships)

	Rates	Fringes
ELECTRICIAN.....	\$ 37.00	18.23

* ELEC0129-004 02/28/2022

ERIE & HURON (Lyme, Ridgefield, Norwalk, Townsend, Wakeman,
Sherman, Peru, Bronson, Hartland, Clarksfield, Norwich,
Greenfield, Fairfield, Fitchville & New London Townships)

	Rates	Fringes
ELECTRICIAN.....	\$ 37.00	18.23

ELEC0141-003 09/01/2019

BELMONT COUNTY

	Rates	Fringes
CABLE SPLICER.....	\$ 30.63	25.87
ELECTRICIAN.....	\$ 30.38	25.87

ELEC0212-003 11/26/2018

BROWN, CLERMONT & HAMILTON

	Rates	Fringes
Sound & Communication Technician.....	\$ 24.35	10.99

ELEC0212-005 11/29/2021

BROWN, CLERMONT, and HAMILTON COUNTIES

	Rates	Fringes
ELECTRICIAN.....	\$ 37.04	20.64

 ELEC0245-001 01/01/2022

ALLEN, HARDIN, VAN WERT & WYANDOT (Crawford, Jackson, Marseilles, Mifflin, Richland, Ridge & Salem Townships)

	Rates	Fringes
Line Construction		
Equipment Operator.....	\$ 32.37	26.5%+7.25
Groundman Truck Driver.....	\$ 18.60	26.5%+7.25
Lineman.....	\$ 42.52	26.5%+7.25

FOOTNOTE: a. Half day's Paid Holiday: The last 4 hours of the workday prior to Christmas or New Year's Day

 ELEC0245-003 01/01/2022

DEFIANCE, FULTON, HANCOCK, HENRY, HURON, LUCAS, OTTAWA, PAULDING, PUTNAM, SANDUSKY, SENECA, WILLIAMS, and WOOD COUNTIES

	Rates	Fringes
Line Construction		
Cable Splicer.....	\$ 48.90	26.5%+7.25
Groundman/Truck Driver.....	\$ 18.60	26.5%+7.25
Heli-arc Welding.....	\$ 40.76	26.5%+7.25
Lineman.....	\$ 45.52	26.5%+7.25
Operator - Class 1.....	\$ 34.18	26.5%+7.25
Operator - Class 2.....	\$ 28.32	26.5%+7.25
Traffic Signal & Lighting Technician.....	\$ 38.27	26.5%+7.25

FOOTNOTE: a. 6 Observed Holidays: New Year's Day; Memorial Day; Independence Day; Labor Day; Thanksgiving Day; & Christmas Day. Employees who work on a holiday shall be paid at a rate of double their applicable classified straight-time rates for the work performed on such holiday.

 ELEC0245-004 01/01/2022

ERIE COUNTY

	Rates	Fringes
Line Construction		
Cable Splicer.....	\$ 49.14	26.75%+6.75
Cablesplicer.....	\$ 48.90	26.5%+7.25
Groundman/Truck Driver.....	\$ 18.60	26.5%+7.25
Lineman.....	\$ 42.52	26.5%+7.25
Operator - Class 1.....	\$ 34.14	26.5%+7.25
Operator - Class 2.....	\$ 28.32	26.5%+7.25

FOOTNOTE: a. 6 Observed Holidays: New Year's Day; Memorial Day; Independence Day; Labor Day; Thanksgiving Day; & Christmas Day. Employees who work on a holiday shall be paid at a rate of double their applicable classified

straight-time rates for the work performed on such holiday.

 ELEC0246-001 10/29/2018

	Rates	Fringes
ELECTRICIAN.....	\$ 38.00	84%+a

FOOTNOTE: a. 1 1/2 Paid Holidays: The last scheduled workday prior to Christmas & 4 hours on Good Friday.

 ELEC0306-005 05/28/2018

MEDINA (Brunswick, Chatham, Granger, Guilford, Harrisville, Hinckley, Homer, Lafayette, Medina, Montville, Sharon, Spencer, Wadsworth, Westfield & York Townships), PORTAGE (Atwater, Aurora, Brimfield, Deerfield, Franklin, Mantua, Randolph, Ravenna, Rootstown, Shalersville, Streetsboro & Suffield Townships), SUMMIT & WAYNE (Baughman, Canaan, Chester, Chippewa, Congress, Green, Milton, & Wayne Townships)

	Rates	Fringes
CABLE SPLICER.....	\$ 36.87	16.56
ELECTRICIAN.....	\$ 34.54	5%+18.06

 ELEC0317-002 06/01/2021

GALLIA & LAWRENCE

	Rates	Fringes
CABLE SPLICER.....	\$ 32.68	18.13
ELECTRICIAN.....	\$ 35.10	27.47

 ELEC0540-005 12/27/2021

CARROLL (Northern half, including Fox, Harrison, Rose & Washington Townships), COLUMBIANA (Knox Township), HOLMES, MAHONING (Smith Township), STARK, TUSCARAWAS (North of Auburn, Clay, Rush & York Townships), and WAYNE (South of Baughman, Chester, Green & Wayne Townships) COUNTIES

	Rates	Fringes
ELECTRICIAN.....	\$ 35.28	22.63

 ELEC0573-003 11/29/2021

ASHTABULA (Colebrook, Wayne, Williamsfield, Orwell & Windsor Townships), GEAUGA (Auburn, Middlefield, Parkman & Troy Townships), MAHONING (Milton Township), PORTAGE (Charlestown, Edinburg, Freedom, Hiram, Nelson, Palmyra, Paris & Windham Townships), and TRUMBULL (Except Liberty & Hubbard Townships)

	Rates	Fringes
ELECTRICIAN.....	\$ 37.04	20.64

 ELEC0575-001 11/29/2021

ADAMS, FAYETTE, HIGHLAND, HOCKING, JACKSON (Bloomfield, Franklin, Hamilton, Jefferson, Lick, Madison, Scioto, Coal, Jackson, Liberty, Milton & Washington Townships), PICKAWAY (Deer Creek, Perry, Pickaway, Salt Creek & Wayne Townships), PIKE (Beaver, Benton, Jackson, Mifflin, Pebble, PeePee, Perry, Seal, Camp Creek, Newton, Scioto, Sunfish, Union & Marion Townships), ROSS, SCIOTO & VINTON (Clinton, Eagle, Elk, Harrison, Jackson, Richland & Swan Townships)

	Rates	Fringes
ELECTRICIAN.....	\$ 35.00	19.76

ELEC0648-001 08/30/2021		

BUTLER and WARREN COUNTIES (Deerfield, Hamilton, Harlan, Massie, Salem, Turtle Creek, Union & Washington Townships)

	Rates	Fringes
CABLE SPLICER.....	\$ 30.50	18.23
ELECTRICIAN.....	\$ 32.00	20.79

ELEC0673-004 02/01/2020		

ASHTABULA (Excluding Orwell, Colebrook, Williamsfield, Wayne & Windsor Townships), GEAUGA (Burton, Chardon, Claridon, Hambden, Huntsburg, Montville, Munson, Newbury & Thompson Townships) and LAKE COUNTIES

	Rates	Fringes
CABLE SPLICER.....	\$ 33.81	21.47
ELECTRICIAN.....	\$ 33.56	21.47

ELEC0683-002 05/31/2021		

CHAMPAIGN, CLARK, DELAWARE, FAIRFIELD, FRANKLIN, MADISON, PICKAWAY (Circleville, Darby, Harrison, Jackson, Madison, Monroe, Muhlenberg, Scioto, Walnut & Washington Townships), and UNION COUNTIES

	Rates	Fringes
CABLE SPLICER.....	\$ 35.50	21.99
ELECTRICIAN.....	\$ 35.50	21.99

ELEC0688-003 05/31/2021		

ASHLAND, CRAWFORD, HURON (Richmond, New Haven, Ripley & Greenwich Townships), KNOX (Liberty, Clinton, Union, Howard, Monroe, Middleberry, Morris, Wayne, Berlin, Pike, Brown & Jefferson Townships), MARION, MORROW, RICHLAND and WYANDOT (Sycamore, Crane, Eden, Pitt, Antrim & Tymochtee Townships) COUNTIES

	Rates	Fringes
ELECTRICIAN.....	\$ 31.00	21.29

 ELEC0972-002 06/01/2021

ATHENS, MEIGS, MONROE, MORGAN, NOBLE, VINTON (Brown, Knox, Madison, Vinton & Wilkesville Townships), and WASHINGTON COUNITIES

	Rates	Fringes
CABLE SPLICER.....	\$ 37.35	27.81
ELECTRICIAN.....	\$ 34.30	27.62

 ELEC1105-001 05/31/2021

COSHOCTON, GUERNSEY, KNOX (Jackson, Clay, Morgan, Miller, Milford, Hilliar, Butler, Harrison, Pleasant & College Townships), LICKING, MUSKINGUM, PERRY, and TUSCARAWAS (Auburn, York, Clay, Jefferson, Rush, Oxford, Washington, Salem, Perry & Bucks Townships) COUNTIES

	Rates	Fringes
ELECTRICIAN.....	\$ 34.25	21.15

 ENGI0018-003 05/01/2019

ASHTABULA, CUYAHOGA, ERIE, GEAUGA, LAKE, LORAIN, MEDINA, PORTAGE, and SUMMIT COUNTIES

	Rates	Fringes
POWER EQUIPMENT OPERATOR		
GROUP 1.....	\$ 38.63	15.20
GROUP 2.....	\$ 38.53	15.20
GROUP 3.....	\$ 37.49	15.20
GROUP 4.....	\$ 36.27	15.20
GROUP 5.....	\$ 30.98	15.20
GROUP 6.....	\$ 38.88	15.20
GROUP 7.....	\$ 39.13	15.20

OPERATING ENGINEER CLASSIFICATIONS

GROUP 1 - Air Compressor on Steel Erection; Barrier Moving Machine; Boiler Operator on Compressor or Generator when mounted on a Rig; Cableway; Combination Concrete Mixer & Tower; Concrete Plant (over 4 yd. Capacity); Concrete Pump; Crane (All Types, Including Boom Truck, Cherry Picker); Crane-Compact, Track or Rubber over 4,000 lbs. capacity; Cranes-Self Erecting, Stationary, Track or Truck (All Configurations); Derrick; Dragline; Dredge (Dipper, Clam or Suction); Elevating Grader or Euclid Loader; Floating Equipment (All Types); Gradall; Helicopter Crew (Operator-Hoist or Winch); Hoe (all types); Hoisting Engine on Shaft or Tunnel Work; Hydraulic Gantry (Lifting System); Industrial-Type Tractor; Jet Engine Dryer (D8 or D9) Diesel Tractor; Locomotive (Standard Gauge); Maintenance Operator Class A; Mixer, Paving (Single or Double Drum); Mucking Machine; Multiple Scraper; Piledriving Machine (All Types); Power Shovel; Prentice Loader; Quad 9 (Double Pusher); Rail Tamper (with auto lifting & aligning device); Refrigerating Machine (Freezer Operation); Rotary Drill, on Caisson work; Rough Terrain Fork Lift with Winch/Hoist; Side-Boom;

Slip-Form Paver; Tower Derrick; Tree Shredder; Trench Machine (Over 24" wide); Truck Mounted Concrete Pump; Tug Boat; Tunnel Machine and/or Mining Machine; Wheel Excavator; and Asphalt Plant Engineer (Cleveland District Only).

GROUP 2 - Asphalt Paver; Automatic Subgrader Machine, Self-Propelled (CMI Type); Bobcat Type and/or Skid Steer Loader with Hoe Attachment Greater than 7,000 lbs.; Boring Machine More than 48"; Bulldozer; Endloader; Horizontal Directional Drill (Over 50,000 ft lbs thrust); Hydro Milling Machine; Kolman-type Loader (production type-Dirt); Lead Greaseman; Lighting & Traffic Signal Installation Equipment (includes all groups or classifications); Material Transfer Equipment (Shuttle Buggy) Asphalt; Pettibone-Rail Equipment; Power Grader; Power Scraper; Push Cat; Rotomill (all), Grinders & Planers of All types; Trench Machine (24" wide & under); Vermeer type Concrete Saw; and Maintenance Operators (Portage and Summit Counties Only).

GROUP 3 - A-Frame; Air Compressor on Tunnel Work (low pressure); Asphalt Plant Engineer (Portage and Summit Counties Only); Bobcat-type and/or Skid Steer Loader with or without Attachments; Highway Drills (all types); Locomotive (narrow gauge); Material Hoist/Elevator; Mixer, Concrete (more than one bag capacity); Mixer, one bag capacity (Side Loader); Power Boiler (Over 15 lbs. Pressure) Pump Operator installing & operating Well Points; Pump (4" & over discharge); Roller, Asphalt; Rotovator (lime soil stabilizer); Switch & Tie Tampers (without lifting & aligning device); Utility Operator (Small equipment); Welding Machines; and Railroad Tie Inserter/Remover; Articulating/straight bed end dumps if assigned (minus \$4.00 per hour).

GROUP 4 - Backfiller; Ballast Re-locator; Bars, Joint & Mesh Installing Machine; Batch Plant; Boring Machine Operator (48" or less); Bull Floats; Burlap & Curing Machine; Concrete Plant (capacity 4 yd. & under); Concrete Saw (Multiple); Conveyor (Highway); Crusher; Deckhand; Farm-type Tractor with attachments (highway); Finishing Machine; Fireperson, Floating Equipment (all types); Forklift; Form Trencher; Hydro Hammer expect masonry; Hydro Seeder; Pavement Breaker; Plant Mixer; Post Driver; Post Hole Digger (Power Auger); Power Brush Burner; Power Form Handling Equipment; Road Widening Trencher; Roller (Brick, Grade & Macadam); Self-Propelled Power Spreader; Self-Propelled Power Subgrader; Steam Fireperson; Tractor (Pulling Sheepfoot, Roller or Grader); and Vibratory Compactor with Integral Power.

GROUP 5 - Compressor (Portable, Sewer, Heavy & Highway); Drum Fireperson (Asphalt Plant); Generator; Masonry Fork Lift; Inboard-Outboard Motor Boat Launch; Oil Heater (asphalt plant); Oiler/Helper; Power Driven Heater; Power Sweeper & Scrubber; Pump (under 4" discharge); Signaller; Tire Repairperson; VAC/ALLS; Cranes - Compact, track or rubber under 4,000 pound capacity; fueling and greasing; and Chainmen.

GROUP 6 - Master Mechanic & Boom from 150 to 180.

GROUP 7 - Boom from 180 and over.

 ENGI0018-004 05/01/2019

ADAMS, ALLEN, ASHLAND, ATHENS, AUGLAIZE, BELMONT, BROWN,
 BUTLER, CARROLL, CHAMPAIGN, CLARK, CLERMONT, CLINTON,
 COSHOCTON, CRAWFORD, DARKE, DEFIANCE, DELAWARE, FAIRFIELD,
 FAYETTE, FRANKLIN, FULTON, GALLIA, GREENE, GUERNSEY, HAMILTON,
 HANCOCK, HARDIN, HARRISON, HENRY, HIGHLAND, HOCKING, HOLMES,
 HURON, JACKSON, JEFFERSON, KNOX, LAWRENCE, LICKING, LOGAN,
 LUCAS, MADISON, MARION, MEIGS, MERCER, MIAMI, MONROE,
 MONTGOMERY, MORGAN, MORROW, MUSKINGUM, NOBLE, OTTAWA, PAULDING,
 PERRY, PICKAWAY, PIKE, PREBLE, PUTNAM, RICHLAND, ROSS,
 SANDUSKY, SCIOTO, SENECA, SHELBY, STARK, TUSCARAWAS, UNION, VAN
 WERT, VINTON, WARREN, WASHINGTON, WAYNE, WILLIAMS, WOOD, and
 YANDOT COUNTIES

	Rates	Fringes
POWER EQUIPMENT OPERATOR		
GROUP 1.....	\$ 37.14	15.20
GROUP 2.....	\$ 37.02	15.20
GROUP 3.....	\$ 35.98	15.20
GROUP 4.....	\$ 34.80	15.20
GROUP 5.....	\$ 29.34	15.20
GROUP 6.....	\$ 37.39	15.20
GROUP 7.....	\$ 37.64	15.20

OPERATING ENGINEER CLASSIFICATIONS

GROUP 1 - Air Compressor on Steel Erection; Barrier Moving Machine; Boiler Operator on Compressor or Generator when mounted on a Rig; Cableway; Combination Concrete Mixer & Tower; Concrete Plant (over 4 yd. Capacity); Concrete Pump; Crane (All Types, Including Boom Truck, Cherry Picker); Crane-Compact, Track or Rubber over 4,000 lbs. capacity; Cranes-Self Erecting, Stationary, Track or Truck (All Configurations); Derrick; Dragline; Dredge (Dipper, Clam or Suction); Elevating Grader or Euclid Loader; Floating Equipment (All Types); Gradall; Helicopter Crew (Operator-Hoist or Winch); Hoe (all types); Hoisting Engine on Shaft or Tunnel Work; Hydraulic Gantry (Lifting System); Industrial-Type Tractor; Jet Engine Dryer (D8 or D9) Diesel Tractor; Locomotive (Standard Gauge); Maintenance Operator Class A; Mixer, Paving (Single or Double Drum); Mucking Machine; Multiple Scraper; Piledriving Machine (All Types); Power Shovel; Prentice Loader; Quad 9 (Double Pusher); Rail Tamper (with auto lifting & aligning device); Refrigerating Machine (Freezer Operation); Rotary Drill, on Caisson work; Rough Terrain Fork Lift with Winch/Hoist; Side-Boom; Slip-Form Paver; Tower Derrick; Tree Shredder; Trench Machine (Over 24" wide); Truck Mounted Concrete Pump; Tug Boat; Tunnel Machine and/or Mining Machine; and Wheel Excavator.

GROUP 2 - Asphalt Paver; Automatic Subgrader Machine, Self-Propelled (CMI Type); Bobcat Type and/or Skid Steer Loader with Hoe Attachment Greater than 7,000 lbs.; Boring Machine More than 48"; Bulldozer; Endloader; Hydro Milling Machine; Horizontal Directional Drill (over 50,000 ft. lbs. thrust); Kolman-type Loader (production type-Dirt); Lead Greaseman; Lighting & Traffic Signal Installation Equipment (includes all groups or classifications); Material Transfer Equipment (Shuttle Buggy) Asphalt; Pettibone-Rail Equipment; Power Grader; Power Scraper; Push Cat; Rotomill

(all), Grinders & Planers of All types; Trench Machine (24" wide & under); and Vermeer type Concrete Saw.

GROUP 3 - A-Frame; Air Compressor on Tunnel Work (low pressure); Asphalt Plant Engineer; Bobcat-type and/or Skid Steer Loader with or without Attachments; Highway Drills (all types); Locomotive (narrow gauge); Material Hoist/Elevator; Mixer, Concrete (more than one bag capacity); Mixer, one bag capacity (Side Loader); Power Boiler (Over 15 lbs. Pressure) Pump Operator installing & operating Well Points; Pump (4" & over discharge); Railroad Tie Inserter/Remover; Roller, Asphalt; Rotovator (lime soil stabilizer); Switch & Tie Tampers (without lifting & aligning device); Utility Operator (Small equipment); and Welding Machines; Articulating/straight bed end dumps if assigned (minus \$4.00 per hour.

GROUP 4 - Backfiller; Ballast Re-locator; Bars, Joint & Mesh Installing Machine; Batch Plant; Boring Machine Operator (48" or less); Bull Floats; Burlap & Curing Machine; Concrete Plant (capacity 4 yd. & under); Concrete Saw (Multiple); Conveyor (Highway); Crusher; Deckhand; Farm-type Tractor with attachments (highway); Finishing Machine; Fireperson, Floating Equipment (all types); Fork Lift; Form Trencher; Hydro Hammer expect masonry; Hydro Seeder; Pavement Breaker; Plant Mixer; Post Driver; Post Hole Digger (Power Auger); Power Brush Burner; Power Form Handling Equipment; Road Widening Trencher; Roller (Brick, Grade & Macadam); Self-Propelled Power Spreader; Self-Propelled Power Subgrader; Steam Fireperson; Tractor (Pulling Sheepfoot, Roller or Grader); and Vibratory Compactor with Integral Power.

GROUP 5 - Compressor (Portable, Sewer, Heavy & Highway); Drum Fireperson (Asphalt Plant); Generator; Masonary Forklift; Inboard-Outboard Motor Boat Launch; Oil Heater (asphalt plant); Oiler/Helper; Power Driven Heater; Power Sweeper & Scrubber; Pump (under 4" discharge); Signalperson; Tire Repairperson; VAC/ALLS; Cranes - Compact, track or rubber under 4,000 pound capacity; fueling and greasing; and Chainmen.

GROUP 6 - Master Mechanic & Boom from 150 to 180.

GROUP 7 - Boom from 180 and over.

 ENGI0066-023 06/01/2017

COLUMBIANA, MAHONING & TRUMBULL COUNTIES

	Rates	Fringes
POWER EQUIPMENT OPERATOR		
ASBESTOS; HAZARDOUS/TOXIC		
WASTE PROJECTS		
GROUP 1 - A & B.....	\$ 39.23	19.66
ASBESTOS; HAZARDOUS/TOXIC		
WASTE PROJECTS		
GROUP 2 - A & B.....	\$ 38.90	19.66
ASBESTOS; HAZARDOUS/TOXIC		
WASTE PROJECTS		
GROUP 3 - A & B.....	\$ 34.64	19.66
ASBESTOS; HAZARDOUS/TOXIC		
WASTE PROJECTS		

GROUP 4 - A & B.....\$ 30.70	19.66
ASBESTOS; HAZARDOUS/TOXIC WASTE PROJECTS	
GROUP 5 - A & B.....\$ 27.30	19.66
HAZARDOUS/TOXIC WASTE PROJECTS	
GROUP 1 - C & D.....\$ 35.96	19.66
HAZARDOUS/TOXIC WASTE PROJECTS	
GROUP 2 - C & D.....\$ 35.66	19.66
HAZARDOUS/TOXIC WASTE PROJECTS	
GROUP 3 - C & D.....\$ 31.76	19.66
HAZARDOUS/TOXIC WASTE PROJECTS	
GROUP 4 - C & D.....\$ 28.14	19.66
HAZARDOUS/TOXIC WASTE PROJECTS	
GROUP 5 - C & D.....\$ 25.03	19.66
ALL OTHER WORK	
GROUP 1.....\$ 32.69	19.66
ALL OTHER WORK	
GROUP 2.....\$ 32.42	19.66
ALL OTHER WORK	
GROUP 3.....\$ 28.87	19.66
ALL OTHER WORK	
GROUP 4.....\$ 25.58	19.66
ALL OTHER WORK	
GROUP 5.....\$ 22.75	19.66

GROUP 1 - Rig, Pile Driver or Caisson Type; & Rig, Pile Hydraulic Unit Attached

GROUP 2 - Asphalt Heater Planer; Backfiller with Drag Attachment; Backhoe; Backhoe with Shear attached; Backhoe-Rear Pivotal Swing; Batch Plant-Central Mix Concrete; Batch Plant, Portable concrete; Berm Builder-Automatic; Boat Derrick; Boat-Tug; Boring Machine Attached to Tractor; Bullclam; Bulldozer; C.M.I. Road Builder & Similar Type; Cable Placer & Layer; Carrier-Straddle; Carryall-Scraper or Scoop; Chicago Boom; Compactor with Blade Attached; Concrete Saw (Vermeer or similar type); Concrete Spreader Finisher; Combination, Bidwell Machine; Crane; Crane-Electric Overhead; Crane-Rough Terrain; Crane-Side Boom; Crane-Truck; Crane-Tower; Derrick-Boom; Derrick-Car; Digger-Wheel (Not trencher or road widener); Double Nine; Drag Line; Dredge; Drill-Kenny or Similar Type; Easy Pour Median Barrier Machine (or similar type); Electromatic; Frankie Pile; Gradall; Grader; Gurry; Self-Propelled; Heavy Equipment Robotics Operator/Mechanic; Hoist-Monorail; Hoist-Stationary & Mobile Tractor; Hoist, 2 or 3 drum; Horizontal Directional Drill Operator; Jackall; Jumbo Machine; Kocal & Kuhlman; Land-Seagoing Vehicle; Loader, Elevating; Loader, Front End; Loader, Skid Steer; Locomotive; Mechanic/Welder; Metro Chip Harvester with Boom; Mucking Machine; Paver-Asphalt Finishing Machine; Paver-Road Concrete; Paver-Slip Form (C.M.I. or similar); Place Crete Machine with Boom; Post Driver (Carrier mounted); Power Driven Hydraulic Pump & Jack (When used in Slip Form or Lift Slab Construction); Pump Crete Machine; Regulator-Ballast; Hydraulic Power Unit not attached to Rig for Pile Drillings; Rigs-Drilling; Roto Mill or similar Full Lane (8' Wide & Over); Roto Mill or similar type (Under 8'); Shovel; Slip Form Curb Machine; Speedwing;

Spikemaster; Stonecrusher; Tie Puller & Loader; Tie Tamper; Tractor-Double Boom; Tractor with Attachments; Truck-Boom; Truck-Tire; Trench Machine; Tunnel Machine (Mark 21 Java or similar); & Whirley (or similar type)

GROUP 3 - Asphalt Plant; Bending Machine (Pipeline or similar type); Boring machine, Motor Driven; Chip Harvester without Boom; Cleaning Machine, Pipeline Type; Coating Machine, Pipeline Type; Compactor; Concrete Belt Placer; Concrete Finisher; Concrete Planer or Asphalt; Concrete Spreader; Elevator; Fork Lift (Home building only); Fork lift & Lulls; Fork Lift Walk Behind (Hoisting over 1 buck high); Form Line Machine; Grease Truck operator; Grout Pump; Gunnite Machine; Horizontal Directional Drill Locator; Single Drum Hoist with or without Tower; Huck Bolting Machine; Hydraulic Scaffold (Hoisting building materials); Paving Breaker (Self-propelled or Ridden); Pipe Dream; Pot Fireperson (Power Agitated); Refrigeration Plant; Road Widener; Roller; Sasgen Derrick; Seeding Machine; Soil Stabilizer (Pump type); Spray Cure Machine, Self-Propelled; Straw Blower Machine; Sub-Grader; Tube Finisher or Broom C.M.I. or similar type; & Tugger Hoist

GROUP 4 - Air Curtain Destructor & Similar Type; Batch Plant-Job Related; Boiler Operator; Compressor; Conveyor; Curb Builder, self-propelled; Drill Wagon; Generator Set; Generator-Steam; Heater-Portable Power; Hydraulic Manipulator Crane; Jack-Hydraulic Power driven; Jack-Hydraulic (Railroad); Ladavator; Minor Machine Operator; Mixer-Concrete; Mulching Machine; Pin Puller; Power Broom; Pulverizer; Pump; Road Finishing Machine (Pull Type); Saw-Concrete-Self-Propelled (Highway Work); Signal Person; Spray Cure Machine-Motor Powered; Stump Cutter; Tractor; Trencher Form; Water Blaster; Steam Jenny; Syphon; Vibrator-Gasoline; & Welding Machine

GROUP 5 - Brakeperson; Fireperson; & Oiler

 IRON0017-002 05/01/2021

ASHTABULA (North of Route 6, starting at the Geauga County Line, proceeding east to State Route 45), CUYAHOGA, ERIE (Eastern 2/3), GEAUGA, HURON (East of a line drawn from the north border through Monroeville & Willard), LAKE, LORAIN, MEDINA (North of Old Rte. #224), PORTAGE (West of a line from Middlefield to Shalersville to Deerfield), and SUMMIT (North of Old Rte. #224, including city limits of Barberton) COUNTIES

Rates Fringes

IRONWORKER

Ornamental, Reinforcing, &
 Structural.....\$ 38.03 24.72

 IRON0017-010 05/01/2021

ASHTABULA (Eastern part from Lake Erie on the north to route #322 on the south to include Conneaut, Kingsville, Sheffield, Denmark, Dorset, Cherry Valley, Wayne, Monroe, Pierpont, Richmond, Andover & Williamsfield Townships)

Rates Fringes

IRONWORKER

Structural, including
 metal building erection &
 Reinforcing.....\$ 38.03 24.72

 IRON0044-001 06/01/2021

ADAMS (Western Part), BROWN, BUTLER (Southern Part), CLERMONT,
 CLINTON (South of a line drawn from Blanchester to Lynchburg),
 HAMILTON, HIGHLAND (Excluding eastern one-fifth & portion of
 county inside lines drawn from Marshall to Lynchburg from the
 northern county line through E. Monroe to Marshall) and WARREN
 (South of a line drawn from Blanchester through Morrow to the
 west county line) COUNTIES

	Rates	Fringes
IRONWORKER, REINFORCING.....	\$ 31.32	21.00
Beyond 30-mile radius of Hamilton County Courthouse..	\$ 28.67	21.20
Up to & including 30-mile radius of Hamilton County Courthouse.....	\$ 27.60	20.70

 IRON0044-002 06/01/2021

CLINTON (South of a line drawn from Blanchester to Lynchburg),
 HAMILTON, HIGHLAND (Excluding eastern one-fifth & portion of
 county inside lines drawn from Marshall to Lynchburg from the
 northern county line through E. Monroe to Marshall) & WARREN
 (South of a line drawn from Blanchester through Morrow to the
 west county line)

	Rates	Fringes
IRONWORKER		
Fence Erector.....	\$ 29.75	21.00
Ornamental; Structural.....	\$ 31.32	21.00

 IRON0055-003 07/01/2021

CRAWFORD (Area Between lines drawn from where Hwy #598 & #30
 meet through N. Liberty to the northern border & from said Hwy
 junction point due west to the border), DEFIANCE (S. of a line
 drawn from where Rte. #66 meets the northern line through
 Independence to the eastern county border), ERIE (Western 1/3),
 FULTON, HANCOCK, HARDIN (North of a line drawn from Maysville
 to a point 4 miles south of the northern line on the eastern
 line), HENRY, HURON (West of a line drawn from the northern
 border through Monroeville & Willard), LUCAS, OTTAWA, PUTNAM
 (East of a line drawn from the northern border down through
 Miller City to where #696 meets the southern border), SANDUSKY,
 SENECA, WILLIAMS (East of a line drawn from Pioneer through
 Stryker to the southern border), WOOD & WYANDOT (North of Rte.
 #30)

	Rates	Fringes
IRONWORKER		
Fence Erector.....	\$ 21.30	20.92
Flat Road Mesh.....	\$ 29.77	21.30

Tunnels & Caissons Under		
Pressure.....	\$ 29.77	21.30
All Other Work.....	\$ 31.25	26.90

IRON0147-002 06/01/2021

ALLEN (Northern half), DEFIANCE (Northern part, excluding south of a line drawn from where Rte. #66 meets the northern line through Independence to the eastern county border), MERCER (Northern half), PAULDING, PUTNAM (Western part, excluding east of a line drawn from the northern border down through Miller City to where #696 meets the southern border), VAN WERT, and WILLIAMS (Western part, excluding east of a line drawn from Pioneer through Stryker to the southern border) COUNTIES

	Rates	Fringes
IRONWORKER.....	\$ 30.35	23.40

IRON0172-002 06/01/2021

CHAMPAIGN (Eastern one-third), CLARK (Eastern one-fourth), COSHOCTON (West of a line beginning at the northwestern county line going through Walhonding & Tunnel Hill to the southern county line), CRAWFORD (South of Rte. #30), DELAWARE, FAIRFIELD, FAYETTE, FRANKLIN, HARDIN (Excluding a line drawn from Roundhead to Maysville), HIGHLAND (Eastern one-fifth), HOCKING, JACKSON (Northern half), KNOX, LICKING, LOGAN (Eastern one-third), MADISON, MARION, MORROW, MUSKINGUM (West of a line starting at Adams Mill going to Adamsville & going from Adamsville through Blue Rock to the southern border), PERRY, PICKAWAY, PIKE (Northern half), ROSS, UNION, VINTON and WYANDOT (South of Rte. #30) COUNTIES

	Rates	Fringes
IRONWORKER.....	\$ 32.00	21.00

IRON0207-004 06/01/2021

ASHTABULA (Southern part starting at the Geauga County line), COLUMBIANA (E. of a line from Damascus to Highlandtown), MAHONING (N. of Old Route #224), PORTAGE (E. of a line from Middlefield to Shalersville to Deerfield) & TRUMBULL

	Rates	Fringes
IRONWORKER		
Layout; Sheeter.....	\$ 32.07	26.00
Ornamental; Reinforcing;		
Structural.....	\$ 31.07	26.00
Ornamental; Reinforcing.....	\$ 29.72	25.18

IRON0290-002 06/01/2021

ALLEN (Southern half), AUGLAIZE, BUTLER (North of a line drawn from east to the west county line going through Oxford, Darrtown & Woodsdale), CHAMPAIGN (Excluding east of a line drawn from Catawla to the point where #68 intersects the northern county line), CLARK (Western two-thirds), CLINTON (Excluding south of a line drawn from Blanchester to Lynchburg), DARKE, GREENE, HIGHLAND (Inside lines drawn from

Marshall to Lynchburg & from the northern county line through East Monroe to Marshall), LOGAN (West of a line drawn from West Liberty to where the northern county line meets the western county line of Hardin), MERCER (Southern half), MIAMI, MONTGOMERY, PREBLE, SHELBY & WARREN (Excluding south of a line drawn from Blanchester through Morrow to the western county line) COUNTIES

	Rates	Fringes
IRONWORKER.....	\$ 30.99	23.10

IRON0549-003 12/01/2021		

BELMONT, GUERNSEY, HARRISON, JEFFERSON, MONROE & MUSKINGUM (Excluding portion west of a line starting at Adams Mill going to Adamsville and going from Adamsville through Blue Rock to the south border)

	Rates	Fringes
IRONWORKER.....	\$ 34.44	18.77

IRON0550-004 05/01/2021		

ASHLAND, CARROLL, COLUMBIANA (W. of a line from Damascus to Highlandtown), COSHOCTON (E. of a line beginning at NW Co. line going through Walhonding & Tunnel Hill to the South Co. line), HOLMES, HURON (S. of Old Rte. #224), MAHONING (S. of Old Rte. #224), MEDINA (S. of Old Rte. #224), PORTAGE (S. of Old Rte. #224), RICHLAND, STARK, SUMMIT (S. of Old Rte. #224, Excluding city limits of Barberton), TUSCARAWAS, & WAYNE

	Rates	Fringes
Ironworkers:Structural, Ornamental and Reinforcing.....	\$ 30.17	21.08

IRON0769-004 06/01/2021		

ADAMS (Eastern Half), GALLIA, JACKSON (Southern Half), LAWRENCE & SCIOTO

	Rates	Fringes
IRONWORKER.....	\$ 33.00	27.29

IRON0787-003 06/01/2021		

ATHENS, MEIGS, MORGAN, NOBLE, and WASHINGTON COUNTIES

	Rates	Fringes
IRONWORKER.....	\$ 31.94	23.05

LABO0265-008 05/01/2021		

	Rates	Fringes
LABORER ASHTABULA, ERIE, HURON,		

LORAIN, LUCAS, MAHONING, MEDINA, OTTAWA, PORTAGE, SANDUSKY, STARK, SUMMIT, TRUMBULL & WOOD COUNTIES		
GROUP 1.....	\$ 33.70	11.85
GROUP 2.....	\$ 33.87	11.85
GROUP 3.....	\$ 34.20	11.85
GROUP 4.....	\$ 34.65	11.85
CUYAHOGA AND GEauga COUNTIES ONLY: SEWAGE PLANTS, WASTE PLANTS, WATER TREATMENT FACILITIES, PUMPING STATIONS, & ETHANOL PLANTS		
CONSTRUCTION.....	\$ 34.93	11.85
CUYAHOGA, GEauga & LAKE COUNTIES		
GROUP 1.....	\$ 34.93	11.85
GROUP 2.....	\$ 35.10	11.85
GROUP 3.....	\$ 35.43	11.85
GROUP 4.....	\$ 35.88	11.85
REMAINING COUNTIES OF OHIO		
GROUP 1.....	\$ 33.27	11.85
GROUP 2.....	\$ 33.44	11.85
GROUP 3.....	\$ 33.77	11.85
GROUP 4.....	\$ 35.88	11.85

LABORER CLASSIFICATIONS

GROUP 1 - Asphalt Laborer; Carpenter Tender; Concrete Curing Applicator; Dump Man (Batch Truck); Guardrail and Fence Installer; Joint Setter; Laborer (Construction); Landscape Laborer; Mesh Handlers & Placer; Right-of-way Laborer; Riprap Laborer & Grouter; Scaffold Erector; Seal Coating; Surface Treatment or Road Mix Laborer; Sign Installer; Slurry Seal; Utility Man; Bridge Man; Handyman; Waterproofing Laborer; Flagperson; Hazardous Waste (level D); Diver Tender; Zone Person & Traffic Control

GROUP 2 - Asphalt Raker; Concrete Puddler; Kettle Man Pipeline); Machine Driven Tools (Gas, Electric, Air); Mason Tender; Brick Paver; Mortar Mixer; Power Buggy or Power Wheelbarrow; Paint Stripper; Sheeting & Shoring Man; Surface Grinder Man; Plastic Fusing Machine Operator; Pug Mill Operator; & Vacuum Devices (wet or dry); Rodding Machine Operator; Diver; Screwman or Paver; Screed Person; Water Blast, Hand Held Wand; Pumps 4" & Under (Gas, Air or Electric) & Hazardous Waste (level C); Air Track and Wagon Drill; Bottom Person; Cofferdam (below 25 ft. deep); Concrete Saw Person; Cutting with Burning Torch; Form Setter; Hand Spiker (Railroad); Pipelayer; Tunnel Laborer (without air) & Caisson; Underground Person (working in Sewer and Waterline, Cleaning, Repairing & Reconditioning); Sandblaster Nozzle Person; & Hazardous Waste (level B)

GROUP 3 - Blaster; Mucker; Powder Person; Top Lander; Wrencher (Mechanical Joints & Utility Pipeline); Yarner; Hazardous Waste (level A); Concrete Specialist; Concrete Crew in Tunnels (With Air-pressurized - \$1.00 premium); Curb Setter & Cutter; Grade Checker; Utility Pipeline Tapper; Waterline; and Caulker

GROUP 4 - Miner (With Air-pressurized - \$1.00 premium); & Gunite Nozzle Person

TUNNEL LABORER WITH AIR-PRESSURIZED ADD \$1.00 TO BASE RATE

SIGNAL PERSON WILL RECEIVE THE RATE EQUAL TO THE RATE PAID THE LABORER CLASSIFICATION FOR WHICH HE OR SHE IS SIGNALING.

 PAIN0006-002 05/01/2018

ASHTABULA, CUYAHOGA, GEAUGA, LAKE, LORAIN, PORTAGE (N. of the East-West Turnpike) & SUMMIT (N. of the East-West Turnpike)

	Rates	Fringes
PAINTER		
COMMERCIAL NEW WORK; REMODELING; & RENOVATIONS		
GROUP 1.....	\$ 27.90	16.16
GROUP 2.....	\$ 28.30	16.16
GROUP 3.....	\$ 28.60	16.16
GROUP 4.....	\$ 34.16	16.16
COMMERCIAL REPAINT		
GROUP 1.....	\$ 26.40	16.16
GROUP 2.....	\$ 26.80	16.16
GROUP 3.....	\$ 27.10	16.16

PAINTER CLASSIFICATIONS - COMMERCIAL NEW WORK; REMODELING; & RENOVATIONS

GROUP 1 - Brush; & Roller

GROUP 2 - Sandblasting & Buffing

GROUP 3 - Spray Painting; Closed Steel Above 55 feet; Bridges & Open Structural Steel; Tanks - Water Towers; Bridge Painters; Bridge Riggers; Containment Builders

GROUP 4 - Bridge Blaster

PAINTER CLASSIFICATIONS - COMMERCIAL REPAINT

GROUP 1 - Brush; & Roller

GROUP 2 - Sandblasting & Buffing

GROUP 3 - Spray Painting

 PAIN0007-002 07/01/2021

FULTON, HENRY, LUCAS, OTTAWA (Excluding Allen, Bay, Bono, Catawba Island, Clay Center, Curtice, Danbury, Eagle Beach, Elliston, Elmore, Erie, Fishback, Gem Beach & Genova) & WOOD

	Rates	Fringes
PAINTER		
NEW COMMERCIAL WORK		
GROUP 1.....	\$ 28.74	18.77
GROUP 2.....	\$ 28.74	18.77
GROUP 3.....	\$ 28.74	18.77
GROUP 4.....	\$ 28.74	18.77
GROUP 5.....	\$ 28.74	18.77
GROUP 6.....	\$ 28.74	18.77

GROUP 7.....	\$ 28.74	18.77
GROUP 8.....	\$ 28.74	18.77
GROUP 9.....	\$ 28.74	18.77

REPAINT IS 90% OF JR

PAINTER CLASSIFICATIONS

GROUP 1 - Brush; Spray & Sandblasting Pot Tender

GROUP 2 - Refineries & Refinery Tanks; Surfaces 30 ft. or over where material is applied to or labor performed on above ground level (exterior), floor level (interior)

GROUP 3 - Swing Stage & Chair

GROUP 4 - Lead Abatement

GROUP 5 - All Methods of Spray

GROUP 6 - Solvent-Based Catalized Epoxy Materials of 2 or More Component Materials, to include Solvent-Based Conversion Varnish (excluding water based)

GROUP 7 - Spray Solvent Based Material; Sand & Abrasive Blasting

GROUP 8 - Towers; Tanks; Bridges; Stacks Over 30 Feet

GROUP 9 - Epoxy Spray (excluding water based)

PAIN0012-008 05/01/2019

BUTLER COUNTY

	Rates	Fringes
PAINTER		
GROUP 1.....	\$ 21.95	10.20
GROUP 2.....	\$ 25.30	10.20
GROUP 3.....	\$ 25.80	10.20
GROUP 4.....	\$ 26.05	10.20
GROUP 5.....	\$ 26.30	10.20

PAINTER CLASSIFICATIONS

GROUP 1: Bridge Equipment Tender; Bridge/Containment Builder

GROUP 2: Brush & Roller

GROUP 3: Spray

GROUP 4: Sandblasting; & Waterblasting

GROUP 5: Elevated Tanks; Steeplejack Work; Bridge; & Lead Abatement

PAIN0012-010 05/01/2019

BROWN, CLERMONT, CLINTON, HAMILTON & WARREN

	Rates	Fringes
--	-------	---------

PAINTER

HEAVY & HIGHWAY BRIDGES-
GUARDRAILS-LIGHTPOLES-
STRIPING

Bridge Equipment Tender and Containment Builder....\$ 21.95	10.20
Bridges when highest point of clearance is 60 feet or more; & Lead Abatement Projects.....\$ 26.30	10.20
Brush & Roller.....\$ 25.30	10.20
Sandblasting & Hopper Tender; Water Blasting.....\$ 26.05	10.20
Spray.....\$ 25.80	10.20

PAIN0093-001 12/01/2018

ATHENS, GUERNSEY, HOCKING, MONROE, MORGAN, NOBLE and
WASHINGTON COUNTIES

Rates Fringes

PAINTER

Bridges; Locks; Dams; Tension Towers; & Energized Substations.....\$ 34.04	18.50
Power Generating Facilities.\$ 30.89	18.50

PAIN0249-002 06/01/2020

CLARK, DARKE, GREENE, MIAMI, MONTGOMERY & PREBLE

Rates Fringes

PAINTER

GROUP 1 - Brush & Roller....\$ 24.17	11.22
GROUP 2 - Swing, Scaffold Bridges; Structural Steel; Open Acid Tank; High Tension Electrical Equipment; & Hot Pipes.....\$ 24.17	11.22
GROUP 3 - Spray; Sandblast; Steamclean; Lead Abatement.....\$ 24.92	11.22
GROUP 4 - Steeplejack Work..\$ 25.12	11.22
GROUP 5 - Coal Tar.....\$ 25.67	11.22
GROUP 6 - Bridge Equipment Tender & or Containment Builder.....\$ 32.88	11.22
GROUP 7 - Tanks, Stacks & Towers.....\$ 27.81	11.22
GROUP 8 - Bridge Blaster, Rigger.....\$ 35.88	11.22

PAIN0356-002 09/01/2009

KNOX, LICKING, MUSKINGUM, and PERRY

Rates Fringes

PAINTER

Bridge Equipment Tenders and Containment Builders....\$ 27.93	7.25
------------------------------------------------------------------	------

Bridges; Blasters; and Riggers.....	\$ 34.60	7.25
Brush and Roller.....	\$ 20.93	7.25
Sandblasting; Steam Cleaning; Waterblasting; and Hazardous Work.....	\$ 25.82	7.25
Spray.....	\$ 21.40	7.25
Structural Steel and Swing Stage.....	\$ 25.42	7.25
Tanks; Stacks; and Towers...	\$ 28.63	7.25

PAIN0438-002 12/01/2021

BELMONT, HARRISON and JEFFERSON COUNTIES

Rates Fringes

PAINTER

Bridges, Locks, Dams, Tension Towers & Energized Substations.....	\$ 34.47	20.60
Power Generating Facilities.	\$ 29.65	17.68

PAIN0476-001 06/01/2021

COLUMBIANA, MAHONING, and TRUMBULL COUNTIES

Rates Fringes

PAINTER

GROUP 1.....	\$ 25.79	15.81
GROUP 2.....	\$ 33.10	15.81
GROUP 3.....	\$ 26.00	15.81
GROUP 4.....	\$ 27.12	15.81
GROUP 5.....	\$ 27.79	15.81
GROUP 6.....	\$ 26.69	15.81
GROUP 7.....	\$ 27.79	15.81

PAINTER CLASSIFICATIONS:

GROUP 1: Painters, Brush & Roller

GROUP 2: Bridges

GROUP 3: Structural Steel

GROUP 4: Spray, Except Bar Joist/Deck

GROUP 5: Epoxy/Mastic; Spray- Bar Joist/Deck; Working Above
50 Feet; and Swingstages

GROUP 6: Tanks; Sandblasting

GROUP 7: Towers; Stacks

PAIN0555-002 06/01/2021

ADAMS, HIGHLAND, JACKSON, PIKE & SCIOTO

Rates Fringes

PAINTER

GROUP 1.....	\$ 31.95	17.05
GROUP 2.....	\$ 33.47	17.05

GROUP 3.....	\$ 34.99	17.05
GROUP 4.....	\$ 37.97	17.05

PAINTER CLASSIFICATIONS

GROUP 1 - Containment Builder

GROUP 2 - Brush; Roller; Power Tools, Under 40 feet

GROUP 3 - Sand Blasting; Spray; Steam Cleaning; Pressure Washing; Epoxy & Two Component Materials; Lead Abatement; Hazardous Waste; Toxic Materials; Bulk & Storage Tanks of 25,000 Gallon Capacity or More; Elevated Tanks

GROUP 4 - Stacks; Bridges

 PAIN0639-001 05/01/2011

	Rates	Fringes
Sign Painter & Erector.....	\$ 20.61	3.50+a+b+c

FOOTNOTES: a. 7 Paid Holidays: New Year's Day; Memorial Day; July 4th; Labor Day; Thanksgiving Day; Christmas Day & 1 Floating Day
 b. Vacation Pay: After 1 year's service - 5 days' paid vacation; After 2, but less than 10 years' service - 10 days' paid vacation; After 10, but less than 20 years' service - 15 days' paid vacation; After 20 years' service - 20 days' paid vacation
 c. Funeral leave up to 3 days maximum paid leave for death of mother, father, brother, sister, spouse, child, mother-in-law, father-in-law, grandparent and inlaw provided employee attends funeral

 PAIN0788-002 06/01/2020

ASHLAND, CRAWFORD, ERIE, HANCOCK, HURON, MARION, MORROW, OTTAWA (Allen, Bay, Bono, Catawba Island, Clay Center, Curtice, Danbury, Eagle Beach, Elliston, Elmore, Erie, Fishback, Gem Beach & Genoa), RICHLAND, SANDUSKY, SENECA & WYANDOT

	Rates	Fringes
PAINTER		
Brush & Roller.....	\$ 24.66	14.05
Structural Steel.....	\$ 26.26	14.05

WINTER REPAINT: Between December 1 to March 31 - 90%JR

\$.50 PER HOUR SHALL BE ADDED TO THE RATE OF PAY FOR THE CLASSIFICATION OF WORK:

While working swingstage, boatswain chair, needle beam and horizontal cable. While operating sprayguns, sandblasting, cobblasting and high pressure waterblasting (4000psi).

\$1.00 PER HOUR SHALL BE ADDED TO THE RATE OF PAY FOR THE CLASSIFICATION OF WORK:

For the application of catalized epoxy, including latex epoxy that is deemed hazardous, lead abatement, or for work or

material where special precautions beyond normal work duties must be taken. For working on stacks, tanks, and towers over 40 feet in height.

 PAIN0813-005 12/01/2008

GALLIA, LAWRENCE, MEIGS & VINTON

	Rates	Fringes
PAINTER		
Base Rate.....	\$ 24.83	10.00
Bridges, Locks, Dams &		
Tension Towers.....	\$ 27.83	10.00

 PAIN0841-001 06/01/2018

MEDINA, PORTAGE (South of and including Ohio Turnpike), and
 SUMMIT (South of and including Ohio Turnpike) COUNTIES

	Rates	Fringes
Painters:		
GROUP 1.....	\$ 25.75	14.35
GROUP 2.....	\$ 26.40	14.35
GROUP 3.....	\$ 26.50	14.35
GROUP 4.....	\$ 26.60	14.35
GROUP 5.....	\$ 27.00	14.35
GROUP 6.....	\$ 39.20	11.75
GROUP 7.....	\$ 27.00	14.35

PAINTER CLASSIFICATIONS:

GROUP 1 - Brush, Roller & Paperhanger

GROUP 2 - Epoxy Application

GROUP 3 - Swing Scaffold, Bosum Chair, & Window Jack

GROUP 4 - Spray Gun Operator of Any & All Coatings

GROUP 5 - Sandblast, Painting of Standpipes, etc. from
 Scaffolds, Bridge Work and/or Open Structural Steel,
 Standpipes and/or Water Towers

GROUP 6 - Public & Commerce Transportation, Steel or
 Galvanized, Bridges, Tunnels & Related Support Items
 (concrete)

GROUP 7 - Synthetic Exterior, Drywall Finisher and/or Taper,
 Drywall Finisher and Follow-up Man Using Automatic Tools

 PAIN0841-002 06/01/2018

CARROLL, COSHOCTON, HOLMES, STARK, TUSCARAWAS & WAYNE

	Rates	Fringes
PAINTER		
Bridges; Towers, Poles &		
Stacks; Sandblasting		
Steel; Structural Steel &		

Metalizing.....	\$ 22.78	13.63
Brush & Roller.....	\$ 21.77	13.63
Spray; Tank Interior & Exterior.....	\$ 22.60	13.63

PAIN1020-002 07/01/2020

ALLEN, AUGLAIZE, CHAMPAIGN, DEFIANCE, HARDIN, LOGAN, MERCER,
PAULDING, PUTNAM, SHELBY, VAN WERT, and WILLIAMS COUNTIES

	Rates	Fringes
PAINTER		
Brush & Roller.....	\$ 25.22	14.11
Drywall Finishing & Taping..	\$ 23.92	14.11
Lead Abatement.....	\$ 26.97	14.11
Spray, Sandblasting Pressure Cleaning, & Refinery.....	\$ 25.87	14.11
Swing Stage, Chair, Spiders, & Cherry Pickers...	\$ 25.47	14.11
Wallcoverings.....	\$ 22.82	14.11

All surfaces 40 ft. or over where material is applied to or
labor performed on, above ground level (exterior), floor
level (interior) - \$.50 premium

Applying Coal Tar Products - \$1.00 premium

PAIN1275-002 06/01/2020

DELAWARE, FAIRFIELD, FAYETTE, FRANKLIN, MADISON, PICKAWAY, ROSS
& UNION

	Rates	Fringes
PAINTER		
Bridges.....	\$ 34.64	14.40
Brush; Roller.....	\$ 25.16	14.40
Sandblasting; Steamcleaning; Waterblasting (3500 PSI or Over)& Hazardous Work.....	\$ 25.86	14.40
Spray.....	\$ 25.66	14.40
Stacks; Tanks; & Towers.....	\$ 28.67	14.40
Structural Steel & Swing Stage.....	\$ 25.46	14.40

PLAS0109-001 05/01/2018

MEDINA, PORTAGE, STARK, and SUMMIT COUNTIES

	Rates	Fringes
PLASTERER.....	\$ 28.86	17.11

PLAS0109-003 05/01/2018

CARROLL, HOLMES, TUSCARAWAS, and WAYNE COUNTIES

	Rates	Fringes
--	-------	---------

PLASTERER.....\$ 28.21 17.11

PLAS0132-002 05/01/2018

BROWN, BUTLER, CLERMONT, HAMILTON, HIGHLAND, WARREN COUNTIES

Rates Fringes

PLASTERER.....\$ 28.86 17.11

PLAS0404-002 05/01/2018

ASHTABULA, CUYAHOGA, GEAUGA, AND LAKE COUNTIES

Rates Fringes

PLASTERER.....\$ 29.63 17.11

PLAS0404-003 05/01/2018

LORAIN COUNTY

Rates Fringes

PLASTERER.....\$ 28.86 17.11

PLAS0526-022 05/01/2018

COLUMBIANA, MAHONING, and TRUMBULL COUNTIES

Rates Fringes

PLASTERER.....\$ 28.86 17.11

PLAS0526-023 05/01/2018

BELMONT, HARRISON, and JEFFERSON COUNTIES

Rates Fringes

PLASTERER.....\$ 28.21 17.11

PLAS0886-001 05/01/2018

FULTON, HANCOCK, HENRY, LUCAS, PUTNAM, and WOOD COUNTIES

Rates Fringes

PLASTERER.....\$ 29.63 17.11

PLAS0886-003 05/01/2018

DEFIANCE, ERIE, HURON, OTTAWA, PAULDING, SANDUSKY, and SENECA COUNTIES

Rates Fringes

PLASTERER.....\$ 28.86 17.11

PLAS0886-004 05/01/2018

ALLEN, AUGLAIZE, HARDIN, LOGAN, MERCER, and VAN WERT COUNTIES

Rates Fringes

PLASTERER.....	\$ 28.21	17.11
----------------	----------	-------

PLUM0042-002 07/01/2020

ASHLAND, CRAWFORD, ERIE, HURON, KNOX, LORAIN, MORROW, RICHLAND & WYANDOT

	Rates	Fringes
--	-------	---------

Plumber, Pipefitter, Steamfitter.....	\$ 34.82	24.67
------------------------------------------	----------	-------

PLUM0050-002 07/06/2020

DEFIANCE, FULTON, HANCOCK, HENRY, LUCAS, OTTAWA, PAULDING, PUTNAM, SANDUSKY, SENECA, WILLIAMS & WOOD

	Rates	Fringes
--	-------	---------

Plumber, Pipefitter, Steamfitter.....	\$ 43.60	26.73
------------------------------------------	----------	-------

PLUM0055-003 05/04/2021

ASHTABULA, CUYAHOGA, GEAUGA, LAKE, MEDINA (N. of Rte. #18 & Smith Road) & SUMMIT (N. of Rte. #303, including the corporate limits of the city of Hudson)

	Rates	Fringes
--	-------	---------

PLUMBER.....	\$ 38.47	28.07
--------------	----------	-------

PLUM0083-001 07/01/2017

BELMONT & MONROE (North of Rte. #78)

	Rates	Fringes
--	-------	---------

Plumber and Steamfitter.....	\$ 32.16	31.51
------------------------------	----------	-------

PLUM0094-002 05/01/2020

CARROLL (Northen Half), STARK, and WAYNE COUNTIES

	Rates	Fringes
--	-------	---------

PLUMBER/PIPEFITTER.....	\$ 35.78	21.44
-------------------------	----------	-------

PLUM0120-002 05/03/2021

ASHTABULA, CUYAHOGA, GEAUGA, LAKE, LORAIN (the C.E.I. Power House in Avon Lake), MEDINA (N. of Rte. #18) & SUMMIT (N. of #303)

	Rates	Fringes
--	-------	---------

PIPEFITTER.....	\$ 41.72	26.30
-----------------	----------	-------

PLUM0162-002 06/01/2021

CHAMPAIGN, CLARK, CLINTON, DARKE, FAYETTE, GREENE, MIAMI,
MONTGOMERY & PREBLE

Rates Fringes

Plumber, Pipefitter,
Steamfitter.....\$ 33.40 27.09

PLUM0168-002 06/01/2021

MEIGS, MONROE (South of Rte. #78), MORGAN (South of Rte. #78)
& WASHINGTON

Rates Fringes

PLUMBER/PIPEFITTER.....\$ 37.09 33.26

PLUM0189-002 06/01/2019

DELAWARE, FAIRFIELD, FRANKLIN, HOCKING, LICKING, MADISON,
MARION, PERRY, PICKAWAY, ROSS & UNION

Rates Fringes

Plumber, Pipefitter,
Steamfitter.....\$ 38.45 16.98

PLUM0219-002 06/01/2021

MEDINA (Rte. #18 from eastern edge of Medina Co., west to
eastern corporate limits of the city of Medina, & on the county
road from the west corporate limits of Medina running due west
to and through community of Risley to the western edge of
Medina County - All territory south of this line), PORTAGE, and
SUMMIT (S. of Rte. #303) COUNTIES

Rates Fringes

Plumber and Steamfitter.....\$ 40.42 24.66

PLUM0392-002 06/01/2021

BROWN, BUTLER, CLERMONT, HAMILTON & WARREN

Rates Fringes

PLUMBER/PIPEFITTER.....\$ 35.21 22.99

PLUM0396-001 06/01/2021

COLUMBIANA (Excluding Washington & Yellow Creek Townships &
Liverpool Twp. - Secs. 35 & 36 - West of County Road #427),
MAHONING and TRUMBULL COUNTIES

Rates Fringes

PLUMBER/PIPEFITTER.....\$ 35.35 27.01

PLUM0495-002 06/01/2018

CARROLL (Rose, Monroe, Union, Lee, Orange, Perry & Loudon Townships), COLUMBIANA (Washington & Yellow Creek Townships & Liverpool Township, Secs. 35 & 36, West of County Rd. #427), COSHOCTON, GUERNSEY, HARRISON, HOLMES, JEFFERSON, MORGAN (South to State Rte. #78 & from McConnelville west on State Rte. #37 to the Perry County line), MUSKINGUM, NOBLE, and TUSCARAWAS COUNTIES

	Rates	Fringes
Plumber, Pipefitter, Steamfitter.....	\$ 38.24	23.09

PLUM0577-002 06/01/2019		

ADAMS, ATHENS, GALLIA, HIGHLAND, JACKSON, LAWRENCE, PIKE, SCIOTO & VINTON

	Rates	Fringes
Plumber, Pipefitter, Steamfitter.....	\$ 34.90	24.11

PLUM0776-002 07/01/2020		

ALLEN, AUGLAIZE, HARDIN, LOGAN, MERCER, SHELBY and VAN WERT COUNTIES

	Rates	Fringes
Plumber, Pipefitter, Steamfitter.....	\$ 37.63	25.58

TEAM0377-003 05/01/2021		

STATEWIDE, EXCEPT CUYAHOGA, GEAUGA & LAKE

	Rates	Fringes
TRUCK DRIVER		
GROUP 1.....	\$ 29.74	15.70
GROUP 2.....	\$ 30.16	15.70

TRUCK DRIVER CLASSIFICATIONS

GROUP 1 - Asphalt Distributor; Batch; 4- Wheel Service; 4-Wheel Dump; Oil Distributor & Tandem

GROUP 2 - Tractor-Trailer Combination: Fuel; Pole Trailer; Ready Mix; Semi-Tractor; & Asphalt Oil Spraybar Man When Operated From Cab; 5 Axles & Over; Belly Dump; End Dump; Articulated Dump; Heavy Duty Equipment; Low Boy; & Truck Mechanic

TEAM0436-002 05/01/2021

CUYAHOGA, GEAUGA & LAKE

	Rates	Fringes
TRUCK DRIVER		

GROUP 1.....	\$ 30.65	16.95
GROUP 2.....	\$ 31.15	16.95

GROUP 1: Straight & Dump, Straight Fuel

GROUP 2: Semi Fuel, Semi Tractor, Euclids, Darts, Tank, Asphalt Spreaders, Low Boys, Carry-All, Tourna-Rockers, Hi-Lifts, Extra Long Trailers, Semi-Pole Trailers, Double Hook-Up Tractor Trailers including Team Track & Railroad Siding, Semi-Tractor & Tri-Axle Trailer, Tandem Tractor & Tandem Trailer, Tag Along Trailer, Expandable Trailer or Towing Requiring Road Permits, Ready-Mix (Agitator or Non-Agitator), Bulk Concrete Driver, Dry Batch Truck, Articulated End Dump

WELDERS - Receive rate prescribed for craft performing operation to which welding is incidental.

=====

** Workers in this classification may be entitled to a higher minimum wage under Executive Order 14026 (\$15.00) or 13658 (\$11.25). Please see the Note at the top of the wage determination for more information.

Note: Executive Order (EO) 13706, Establishing Paid Sick Leave for Federal Contractors applies to all contracts subject to the Davis-Bacon Act for which the contract is awarded (and any solicitation was issued) on or after January 1, 2017. If this contract is covered by the EO, the contractor must provide employees with 1 hour of paid sick leave for every 30 hours they work, up to 56 hours of paid sick leave each year. Employees must be permitted to use paid sick leave for their own illness, injury or other health-related needs, including preventive care; to assist a family member (or person who is like family to the employee) who is ill, injured, or has other health-related needs, including preventive care; or for reasons resulting from, or to assist a family member (or person who is like family to the employee) who is a victim of, domestic violence, sexual assault, or stalking. Additional information on contractor requirements and worker protections under the EO is available at <https://www.dol.gov/agencies/whd/government-contracts>.

Unlisted classifications needed for work not included within the scope of the classifications listed may be added after award only as provided in the labor standards contract clauses (29CFR 5.5 (a) (1) (ii)).

The body of each wage determination lists the classification and wage rates that have been found to be prevailing for the cited type(s) of construction in the area covered by the wage determination. The classifications are listed in alphabetical order of "identifiers" that indicate whether the particular rate is a union rate (current union negotiated rate for local), a survey rate (weighted average rate) or a union average rate (weighted union average rate).

Union Rate Identifiers

A four letter classification abbreviation identifier enclosed in dotted lines beginning with characters other than ""SU"" or ""UAVG"" denotes that the union classification and rate were prevailing for that classification in the survey. Example: PLUM0198-005 07/01/2014. PLUM is an abbreviation identifier of the union which prevailed in the survey for this classification, which in this example would be Plumbers. 0198 indicates the local union number or district council number where applicable, i.e., Plumbers Local 0198. The next number, 005 in the example, is an internal number used in processing the wage determination. 07/01/2014 is the effective date of the most current negotiated rate, which in this example is July 1, 2014.

Union prevailing wage rates are updated to reflect all rate changes in the collective bargaining agreement (CBA) governing this classification and rate.

Survey Rate Identifiers

Classifications listed under the ""SU"" identifier indicate that no one rate prevailed for this classification in the survey and the published rate is derived by computing a weighted average rate based on all the rates reported in the survey for that classification. As this weighted average rate includes all rates reported in the survey, it may include both union and non-union rates. Example: SULA2012-007 5/13/2014. SU indicates the rates are survey rates based on a weighted average calculation of rates and are not majority rates. LA indicates the State of Louisiana. 2012 is the year of survey on which these classifications and rates are based. The next number, 007 in the example, is an internal number used in producing the wage determination. 5/13/2014 indicates the survey completion date for the classifications and rates under that identifier.

Survey wage rates are not updated and remain in effect until a new survey is conducted.

Union Average Rate Identifiers

Classification(s) listed under the UAVG identifier indicate that no single majority rate prevailed for those classifications; however, 100% of the data reported for the classifications was union data. EXAMPLE: UAVG-OH-0010 08/29/2014. UAVG indicates that the rate is a weighted union average rate. OH indicates the state. The next number, 0010 in the example, is an internal number used in producing the wage determination. 08/29/2014 indicates the survey completion date for the classifications and rates under that identifier.

A UAVG rate will be updated once a year, usually in January of each year, to reflect a weighted average of the current negotiated/CBA rate of the union locals from which the rate is based.

WAGE DETERMINATION APPEALS PROCESS

1.) Has there been an initial decision in the matter? This can be:

- * an existing published wage determination
- * a survey underlying a wage determination
- * a Wage and Hour Division letter setting forth a position on a wage determination matter
- * a conformance (additional classification and rate) ruling

On survey related matters, initial contact, including requests for summaries of surveys, should be with the Wage and Hour National Office because National Office has responsibility for the Davis-Bacon survey program. If the response from this initial contact is not satisfactory, then the process described in 2.) and 3.) should be followed.

With regard to any other matter not yet ripe for the formal process described here, initial contact should be with the Branch of Construction Wage Determinations. Write to:

Branch of Construction Wage Determinations
Wage and Hour Division
U.S. Department of Labor
200 Constitution Avenue, N.W.
Washington, DC 20210

2.) If the answer to the question in 1.) is yes, then an interested party (those affected by the action) can request review and reconsideration from the Wage and Hour Administrator (See 29 CFR Part 1.8 and 29 CFR Part 7). Write to:

Wage and Hour Administrator
U.S. Department of Labor
200 Constitution Avenue, N.W.
Washington, DC 20210

The request should be accompanied by a full statement of the interested party's position and by any information (wage payment data, project description, area practice material, etc.) that the requestor considers relevant to the issue.

3.) If the decision of the Administrator is not favorable, an interested party may appeal directly to the Administrative Review Board (formerly the Wage Appeals Board). Write to:

Administrative Review Board
U.S. Department of Labor
200 Constitution Avenue, N.W.
Washington, DC 20210

4.) All decisions by the Administrative Review Board are final.

=====
END OF GENERAL DECISIO"

**ESTIMATES AND SUPPORTING DOCUMENTATION
SECTION G-16**

City of Fostoria, Ohio

Curb Ramp Location S County Line from Findlay St to Culbertson

Legend

 Fostoria



City of Fostoria
Curb Ramp Replacement
March 2021

Description	Unit	Quantity	Unit	Unit Price	Total
Walk Removed, Concrete	SF	1,213	SF	\$2.00	\$ 2,426.00
Curb Removed	FT	359	FT	\$5.00	\$ 1,795.00
4" Concrete Walk with 4" Compacted Aggregate Base	SF	1,124	SF	\$10.00	\$ 11,235.40
Truncated Domes	SF	304	SF	\$20.00	\$ 6,080.00
Concrete Curb, Type 6	LF	358	LF	\$25.00	\$ 8,961.25
Maintenance of Traffic	LS	1	LS	\$5,000.00	\$ 5,000.00
Mobilization	LS	1	LS	\$5,000.00	\$ 5,000.00
Cross Walk Line	LF	179	LF	\$10.00	\$ 1,790.00
Seeding and Mulching	SF	372	SF	\$1.00	\$ 372.00
				Total	\$ 42,659.65
				10% Contingency	\$ 4,265.97
				Total	\$ 46,925.62
NOTE: Engineer's estimate includes labor at federal prevailing wages				Labor (40%)	\$ 18,770.25
				Materials (60%)	\$ 28,155.37

The estimated useful life of the Fostoria Countyline Curb Ramp Replacement Improvements is 20 years.

Todd M. Jenkins
Todd M. Jenkins, P.E.
Director of Operations
Peterman Associates, Inc.



Prepared By:
Peterman Associates, Inc.
3480 North Main Street
Findlay, Ohio 45840
(419) 422-6672

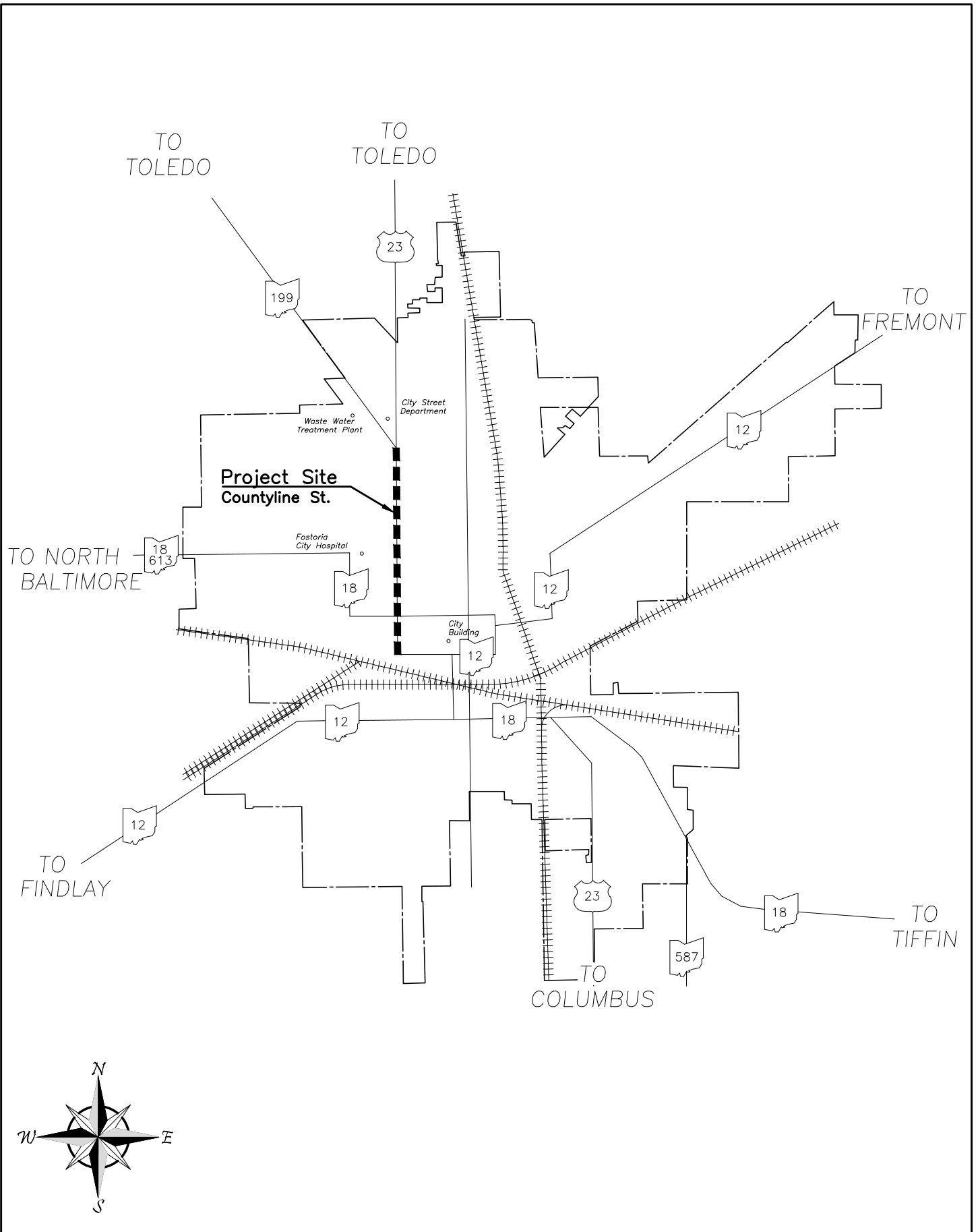

City of Fostoria
Countyline Street A.D.A. Curb Replacement
From Findlay Street to Culbertson Lane

12/9/2019

Vicinity Map

	<u>Culbertson Lane</u> Page 40
	<u>Culbertson Street</u> Page 36
<u>Park Ave</u> Page 33	
(U.S. Route 23)	<u>W. Jackson Street</u> Page 30
	<u>Summit Street</u> Page 27
	<u>Elm Street (State Route 18)</u> Page 24
Countyline Street	<u>Liberty Street</u> Page 22
	<u>W. High Street</u> Page 20
	<u>W. Fremont Street</u> Page 17
	<u>College Avenue</u> Page 14
	<u>W. North Street</u> Page 11
	<u>W. Center Street</u> Page 8
	<u>W. Tiffin Street</u> Page 5
	<u>South Street (U.S. Route 23)</u> Page 3
<u>Findlay Street (State Route 12)</u> Page 1	

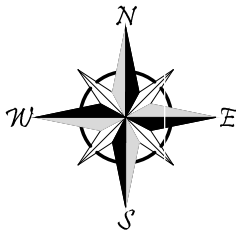

City of Fostoria
Countyline Street A.D.A. Curb Replacement
From Findlay Street to Culbertson Lane

12/9/2019

Reference Map

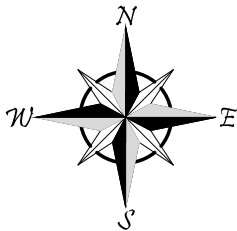
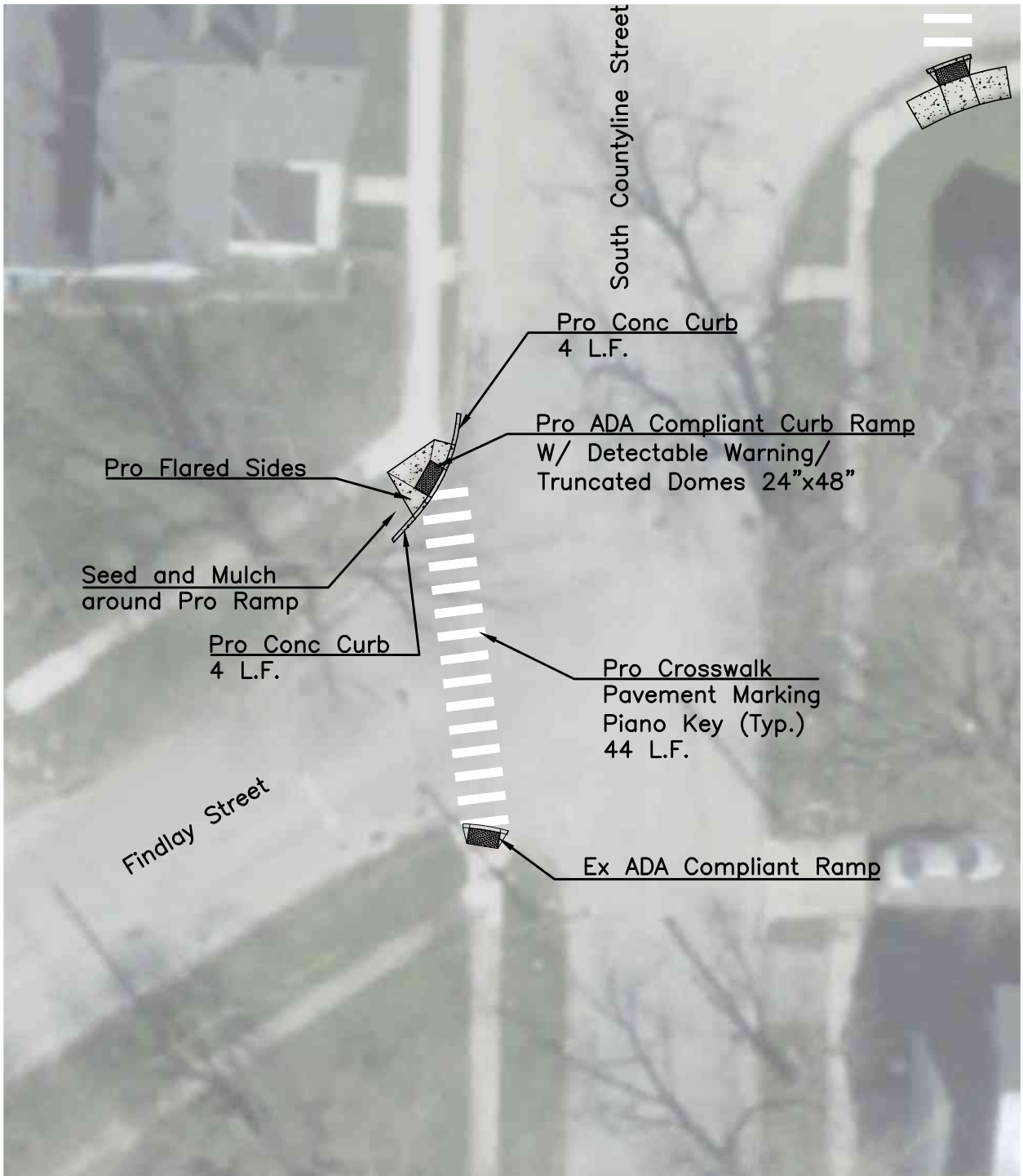

South Countyline Street and Findlay Street



Southwest Corner of South Countyline Street and Findlay Street



Northwest Corner of South Countyline Street and Findlay Street

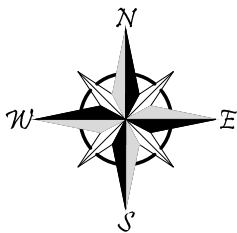
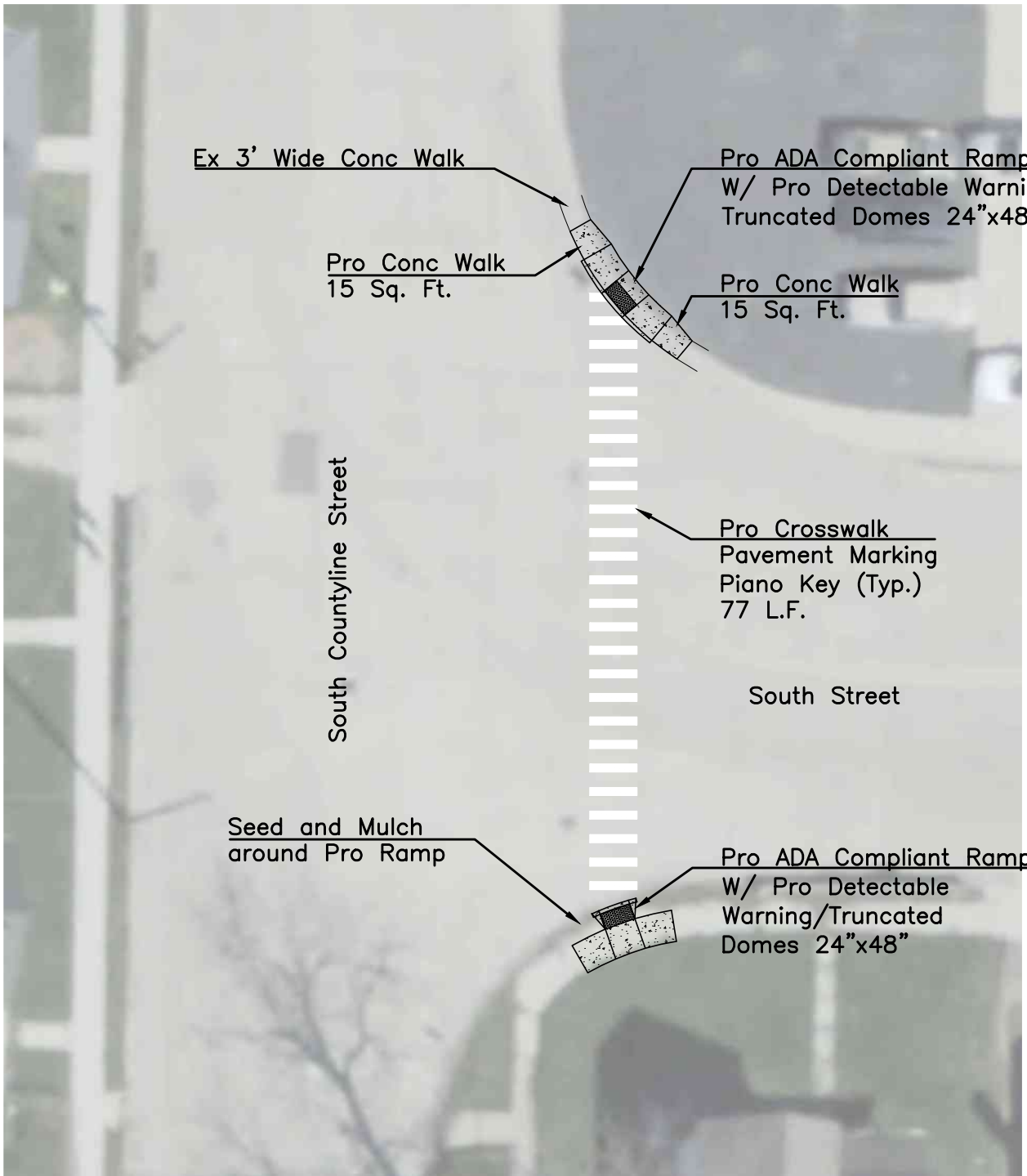

South Countyline Street and South Street



Northeast Corner of South Countyline Street and South Street



Southeast Corner of South Countyline Street and South Street

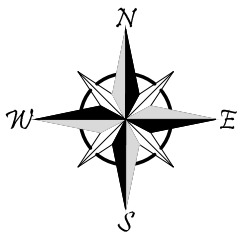
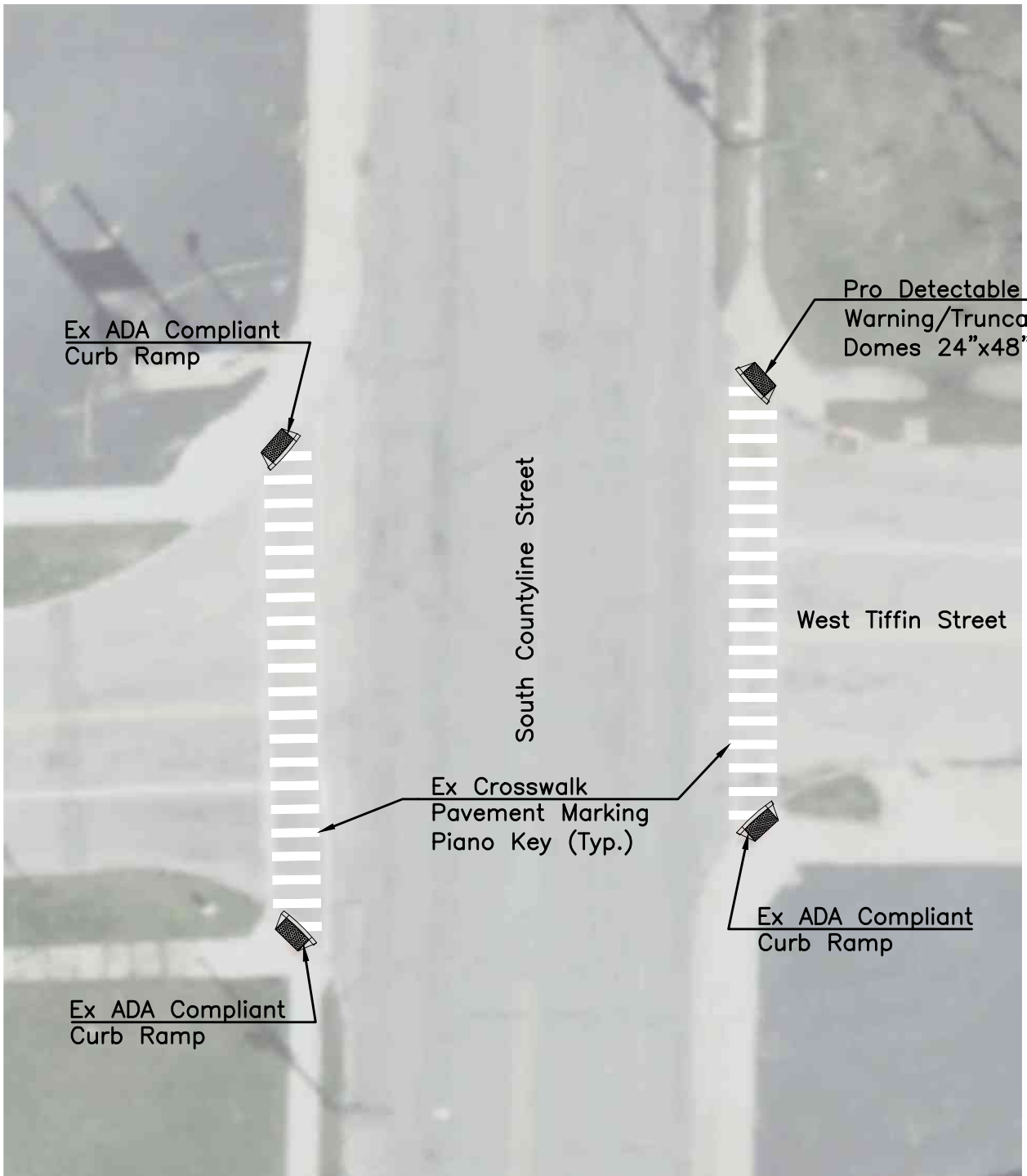

South Countyline Street and West Tiffin Street



Southwest Corner of South Countyline Street and West Tiffin Street



Northwest Corner of South Countyline Street and West Tiffin Street



Northeast Corner of South Countyline Street and West Tiffin Street



Southeast Corner of South Countyline Street and West Tiffin Street

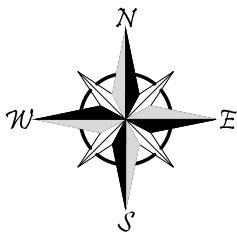
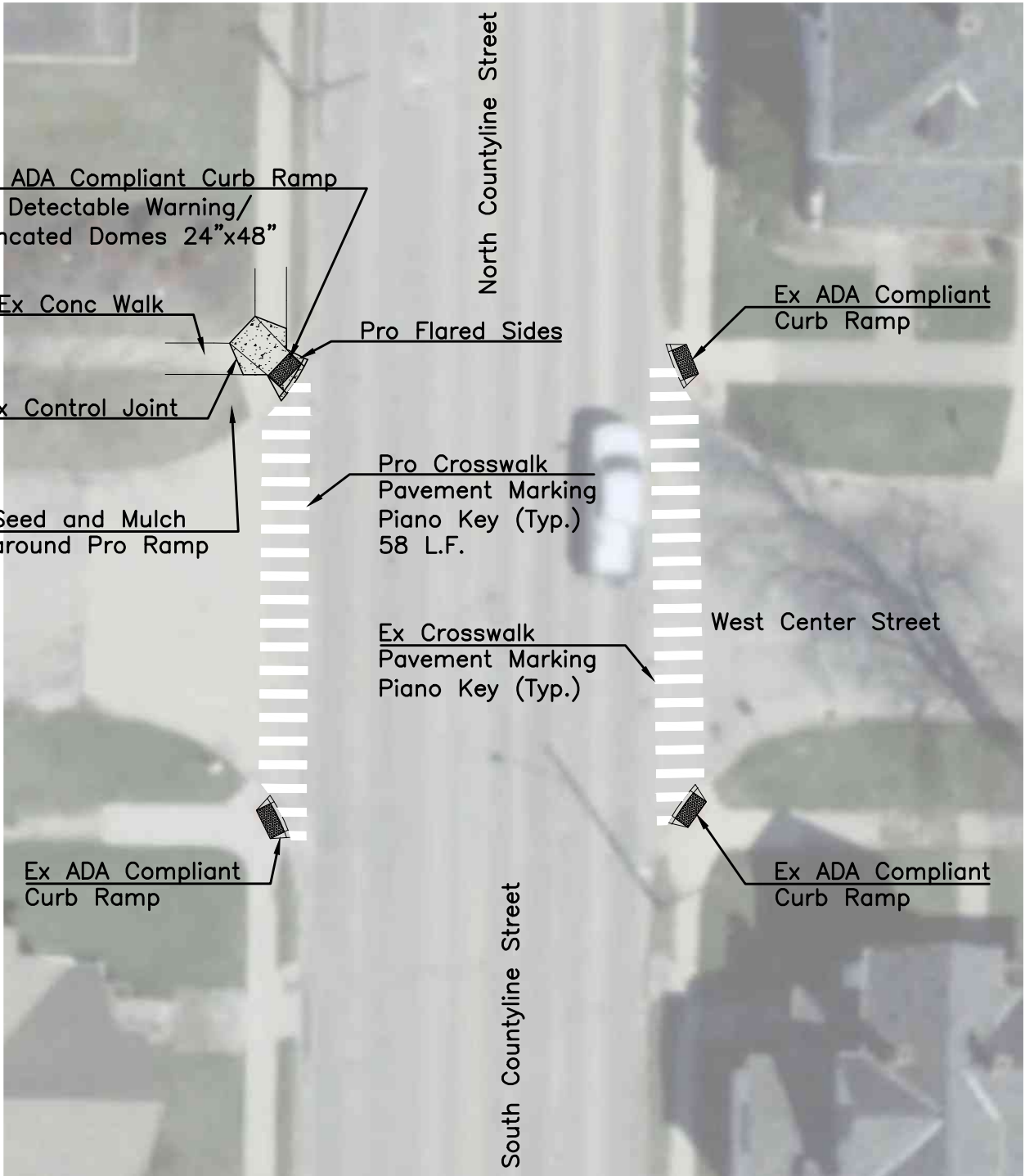

Countyline Street and West Center Street



City of Fostoria
Countyline Street A.D.A. Curb Replacement
From West Tiffin Street to Culbertson Lane

12/9/2019



Southwest Corner of South Countyline Street and West Center Street

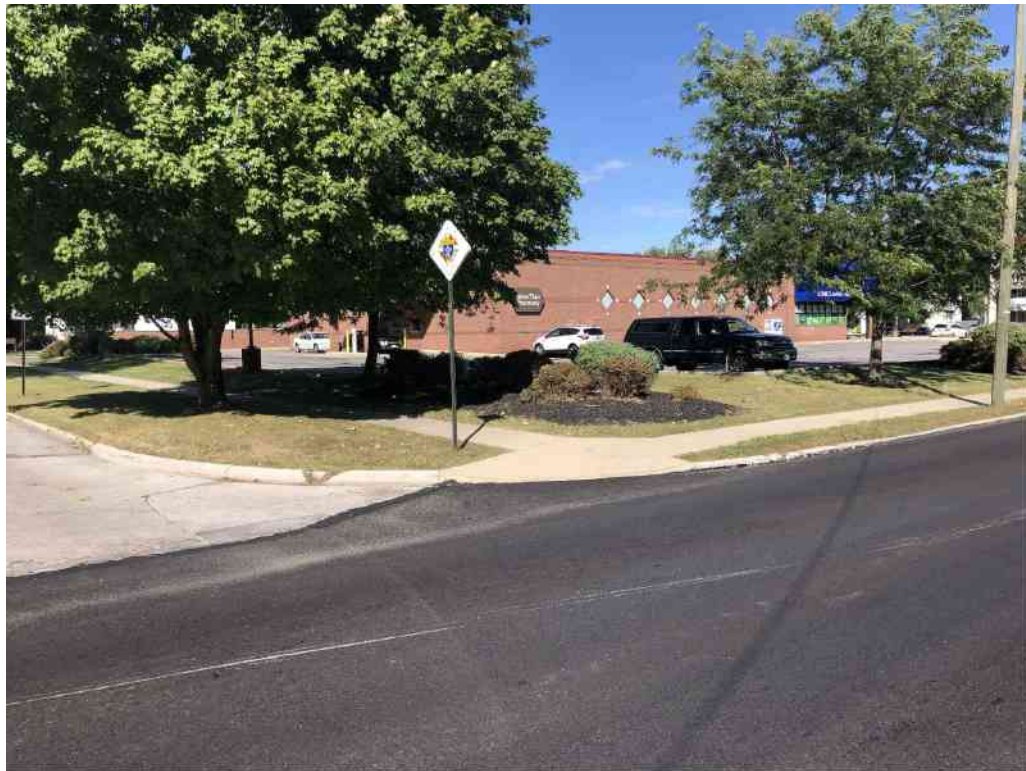

Northwest Corner of North Countyline Street and West Center Street



Northeast Corner of North Countyline Street and West Center Street



Southeast Corner of South Countyline Street and West Center Street

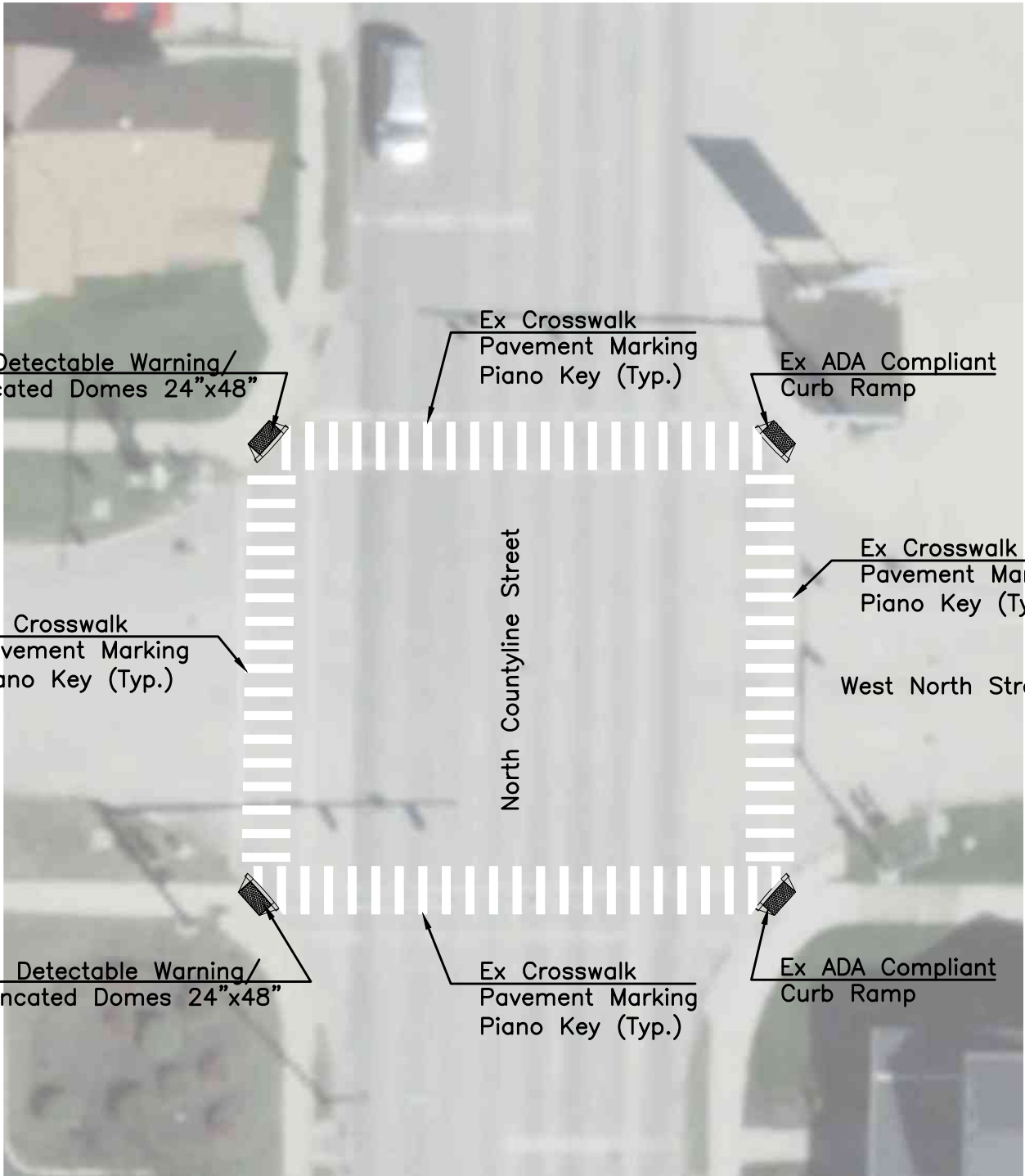

Pro Detectable Warning/
Truncated Domes 24"x48"

Ex Crosswalk
Pavement Marking
Piano Key (Typ.)

Ex ADA Compliant
Curb Ramp

Ex Crosswalk
Pavement Marking
Piano Key (Typ.)

Ex Crosswalk
Pavement Marking
Piano Key (Typ.)

West North Street

North Countyline Street

Pro Detectable Warning/
Truncated Domes 24"x48"

Ex Crosswalk
Pavement Marking
Piano Key (Typ.)

Ex ADA Compliant
Curb Ramp

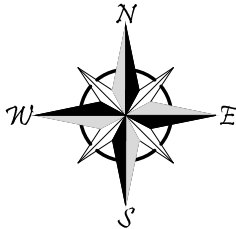

North Countyline Street and West North Street



City of Fostoria
Countyline Street A.D.A. Curb Replacement
From West Tiffin Street to Culbertson Lane

12/9/2019



Southwest Corner of North Countyline Street and West North Street



Northwest Corner of North Countyline Street and West North Street



Northeast Corner of North Countyline Street and West North Street



Southeast Corner of North Countyline Street and West North Street

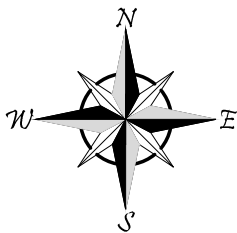
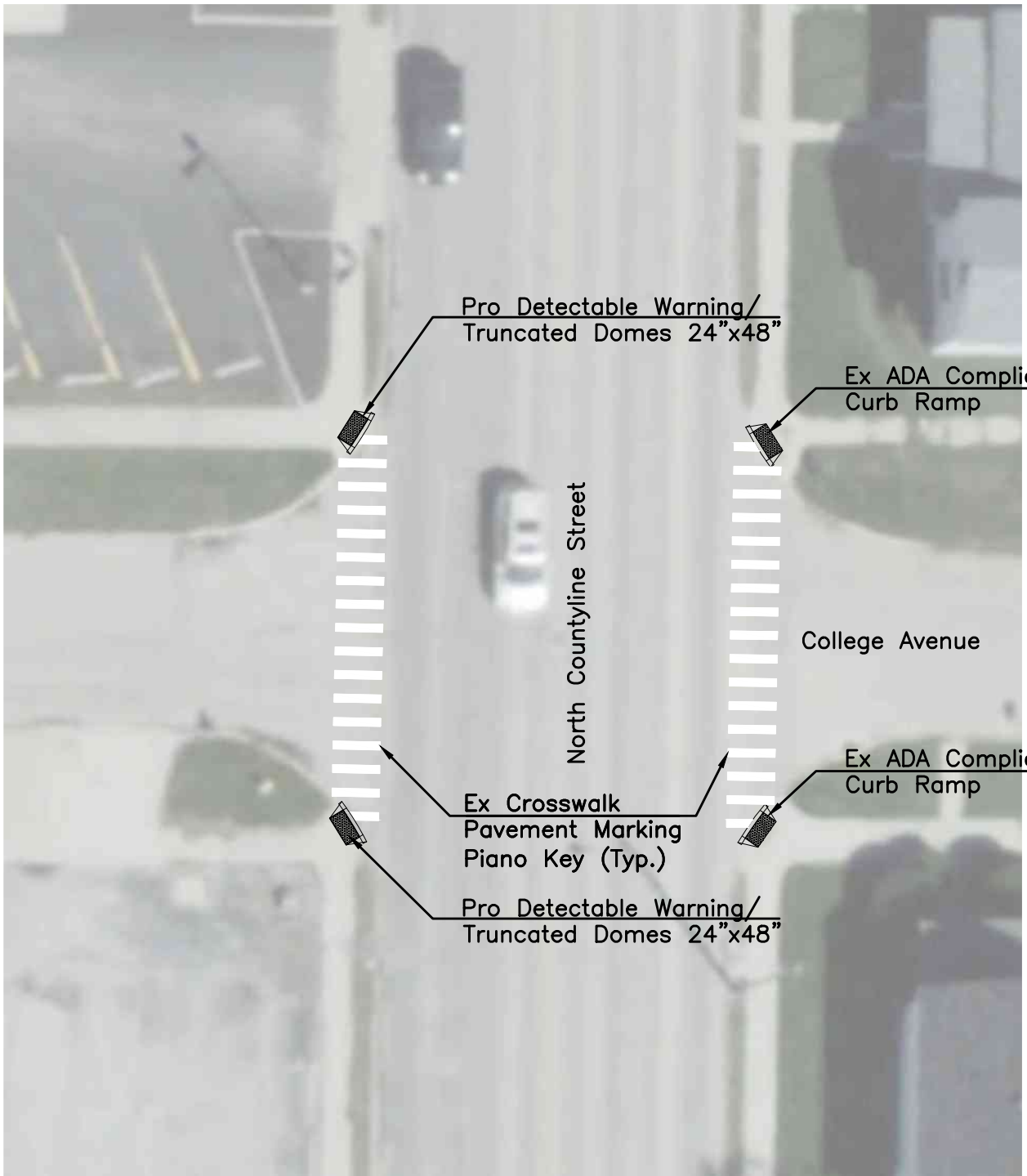

North Countyline Street and College Avenue



Southwest Corner of North Countyline Street and College Avenue



Northwest Corner of North Countyline Street and College Avenue



Northeast Corner of North Countyline Street and College Avenue



Southeast Corner of North Countyline Street and College Avenue

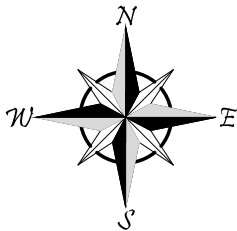
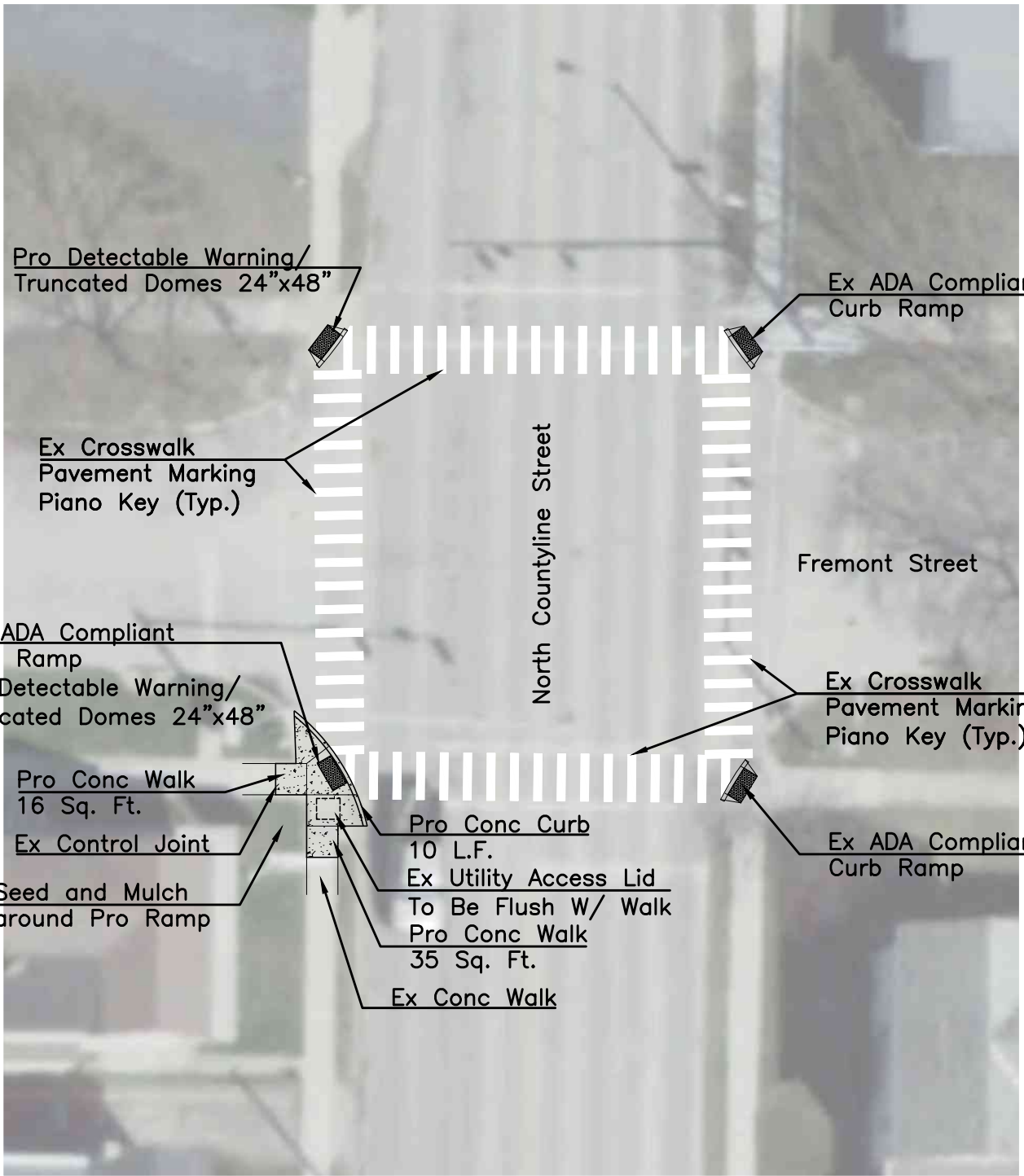

North Countyline Street and Fremont Street



City of Fostoria
Countyline Street A.D.A. Curb Replacement
From West Tiffin Street to Culbertson Lane

12/9/2019

Page 17 of 43



Southwest Corner of North Countyline Street and Fremont Street



Northwest Corner of North Countyline Street and Fremont Street



Northeast Corner of North Countyline Street and Fremont Street



Southeast Corner of North Countyline Street and Fremont Street

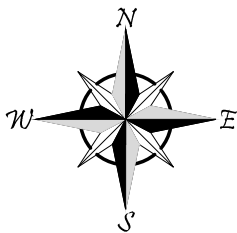
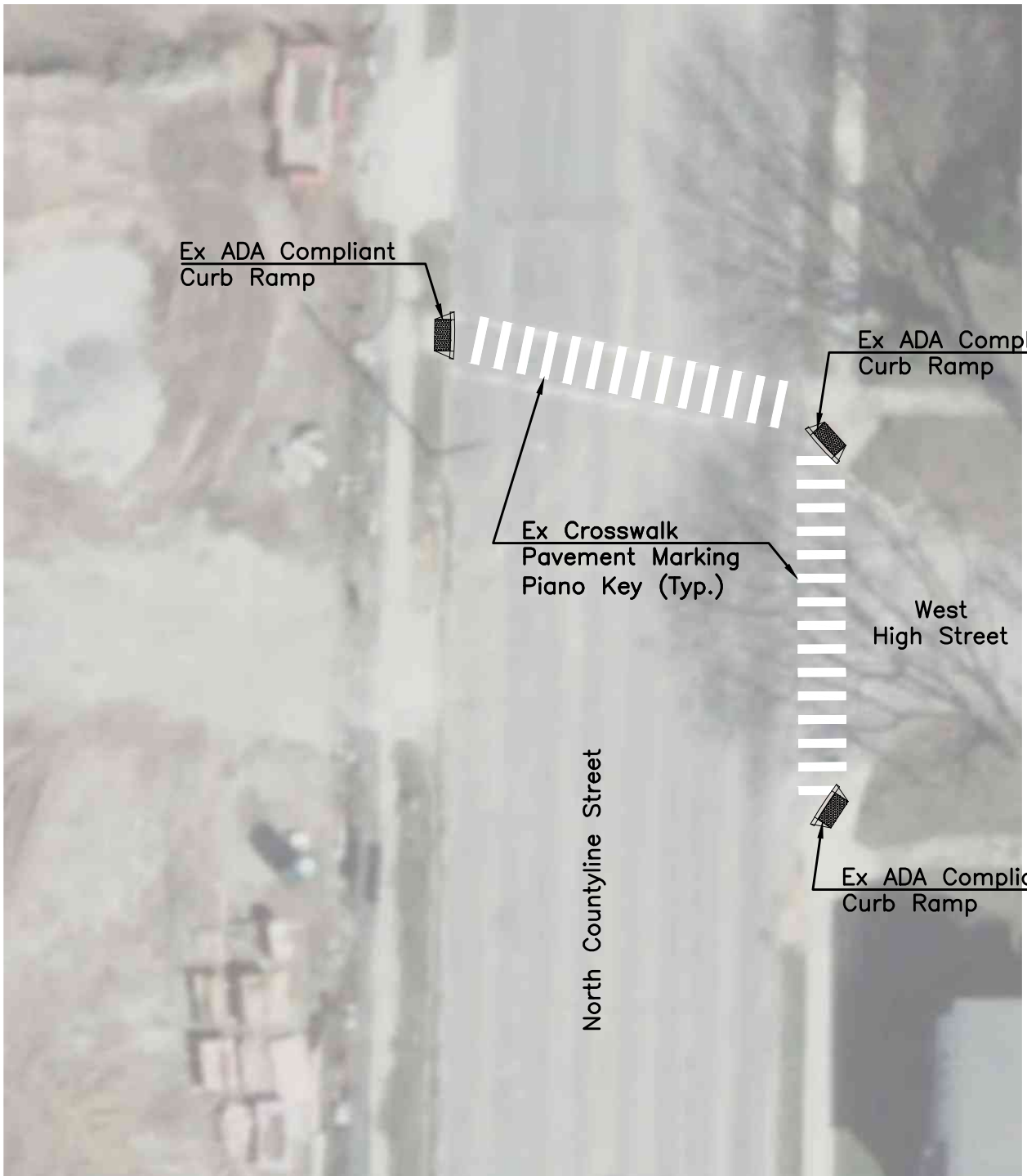

North Countyline Street and West High Street



Northeast Corner of North Countyline Street and West High Street



Southeast Corner of North Countyline Street and West High Street

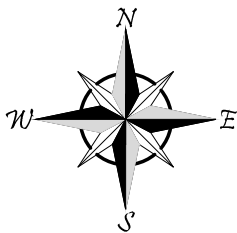
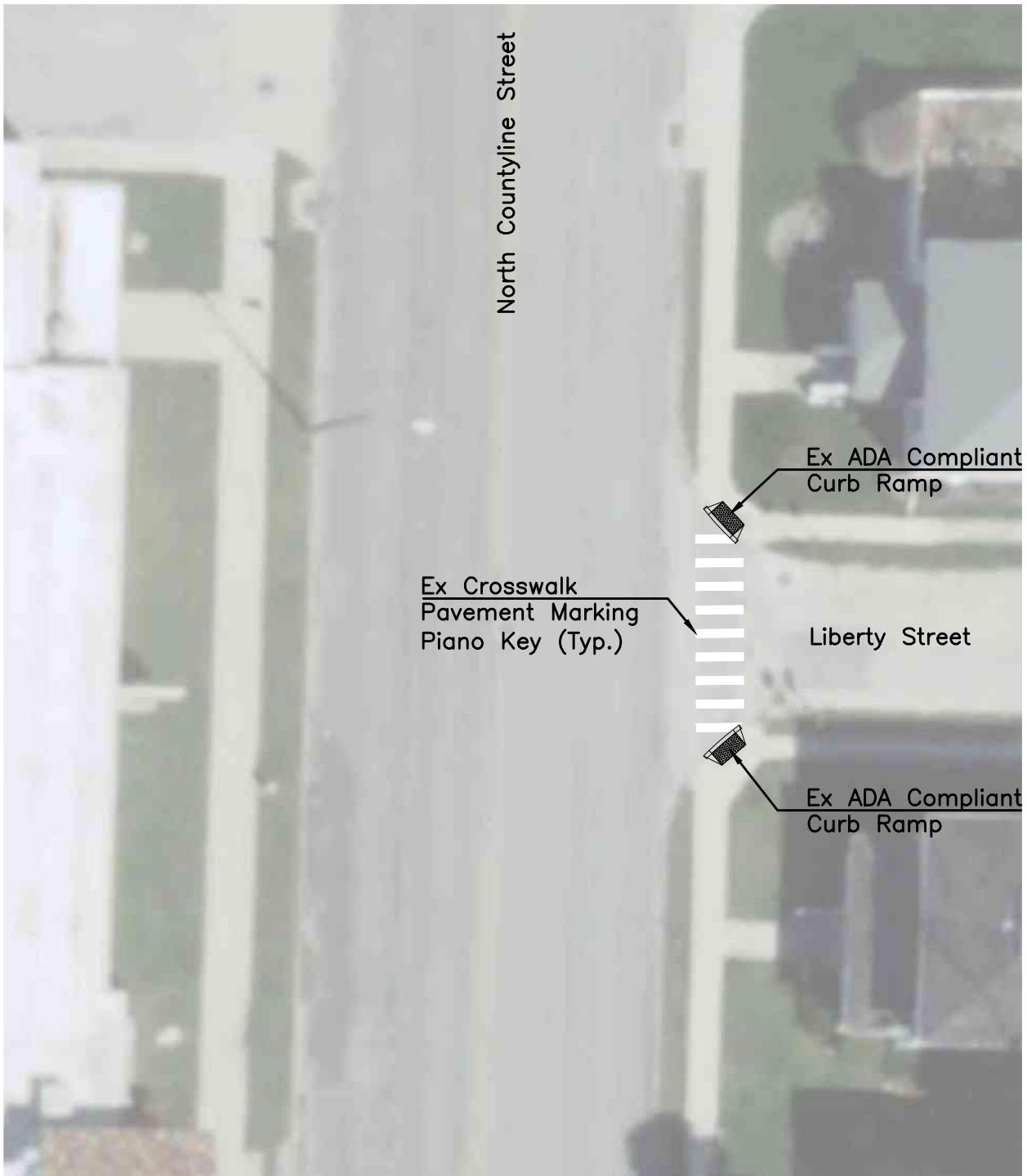

North Countyline Street and Liberty Street



Northeast Corner of North Countyline Street and Liberty Street



Southeast Corner of North Countyline Street and Liberty Street

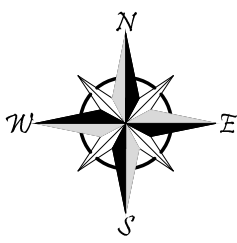
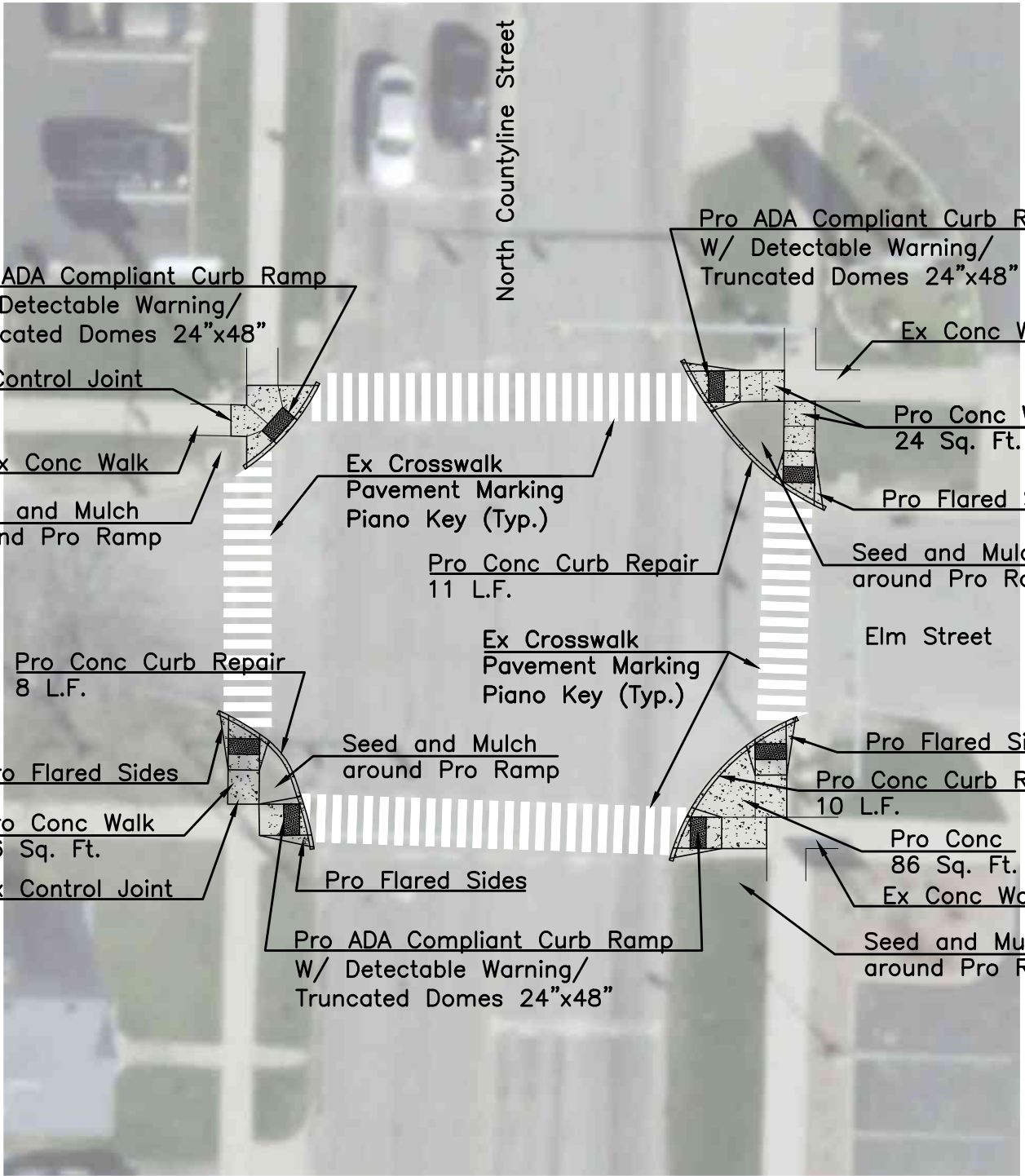

North Countyline Street and Elm Street



City of Fostoria
Countyline Street A.D.A. Curb Replacement
From West Tiffin Street to Culbertson Lane

12/9/2019



Southwest Corner of North Countyline Street and Elm Street



Northwest Corner of North Countyline Street and Elm Street



Northeast Corner of North Countyline Street and Elm Street



Southeast Corner of North Countyline Street and Elm Street

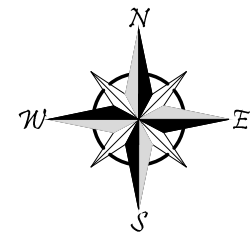
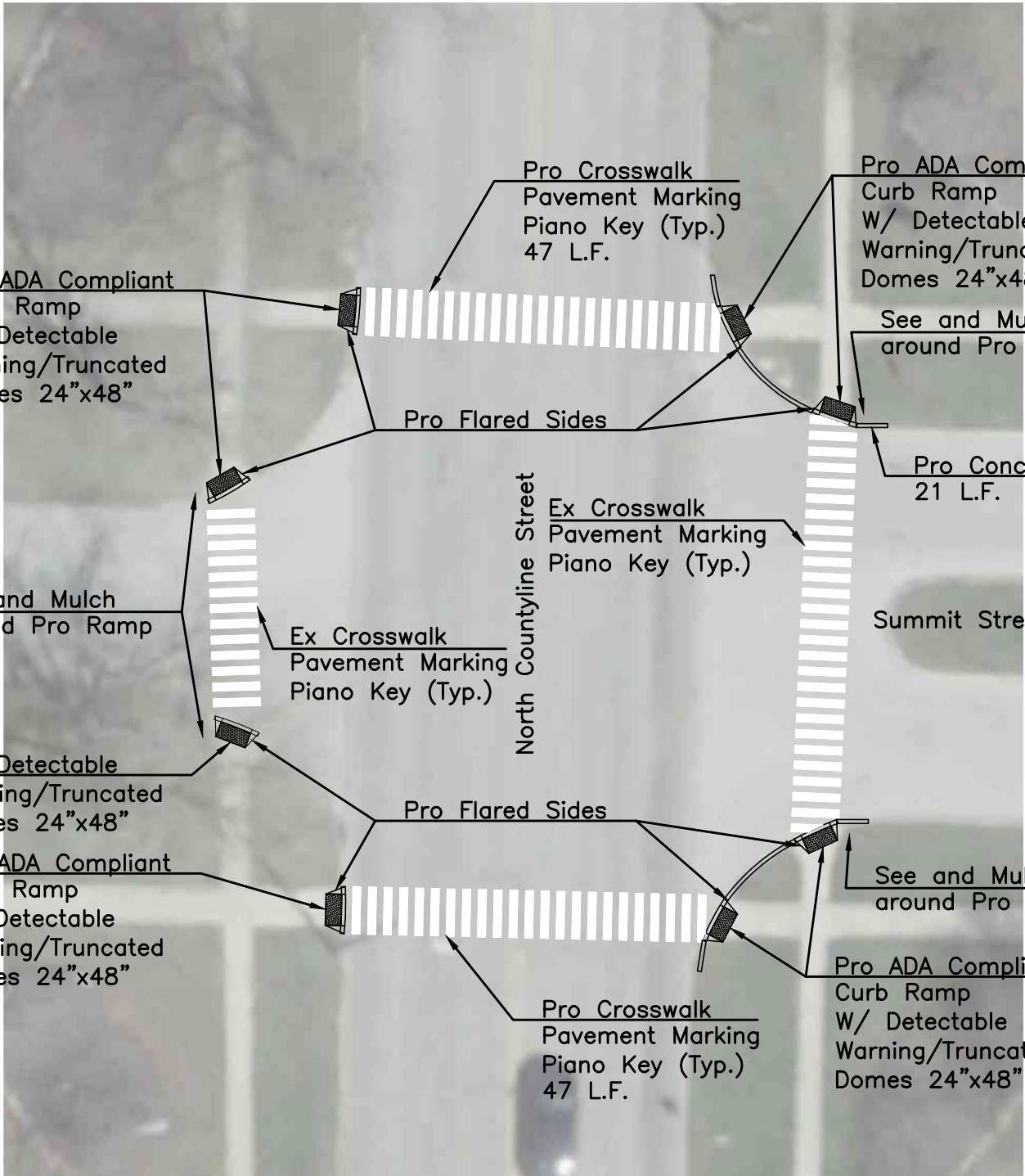

North Countyline Street and Summit Street



City of Fostoria
Countyline Street A.D.A. Curb Replacement
From West Tiffin Street to Culbertson Lane

12/9/2019



Southwest Corner of North Countyline Street and Summit Street



Northwest Corner of North Countyline Street and Summit Street



Northeast Corner of North Countyline Street and Summit Street



Southeast Corner of North Countyline Street and Summit Street

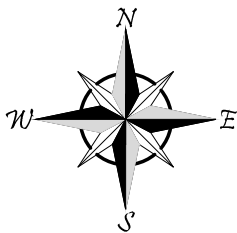
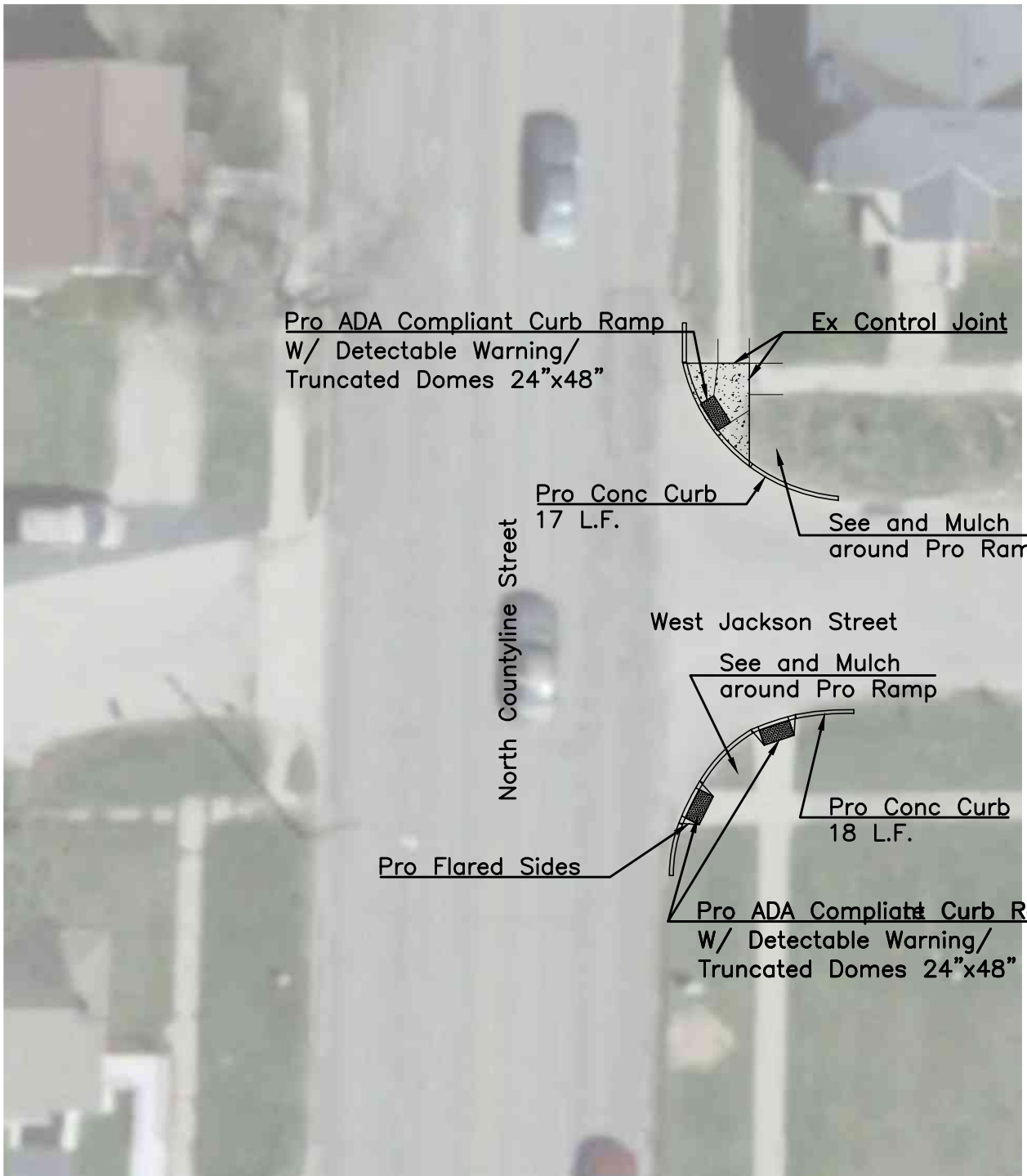

North Countyline Street and West Jackson Street



Southwest Corner of North Countyline Street and West Jackson Street



Northwest Corner of North Countyline Street and West Jackson Street



Northeast Corner of North Countyline Street and West Jackson Street



Southeast Corner of North Countyline Street and West Jackson Street

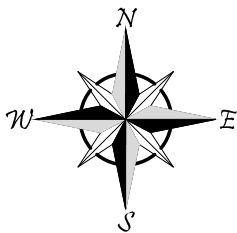
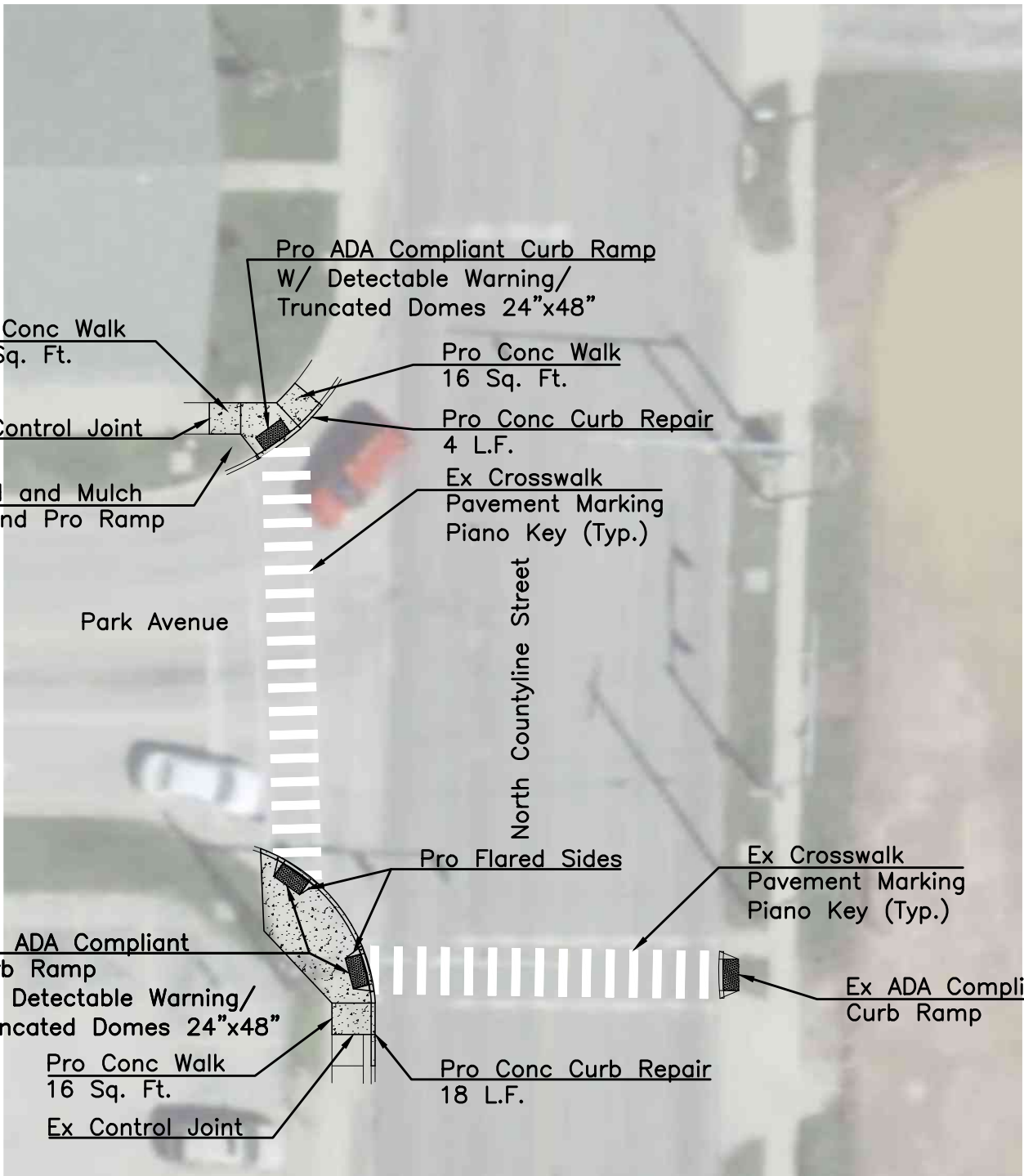

North Countyline Street and Park Avenue



Southwest Corner of North Countyline Street and Park Avenue



Northwest Corner of North Countyline Street and Park Avenue



Southeast Side of North Countyline Street and Park Avenue

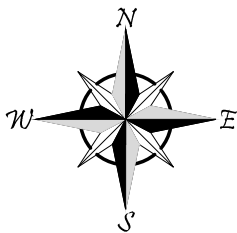
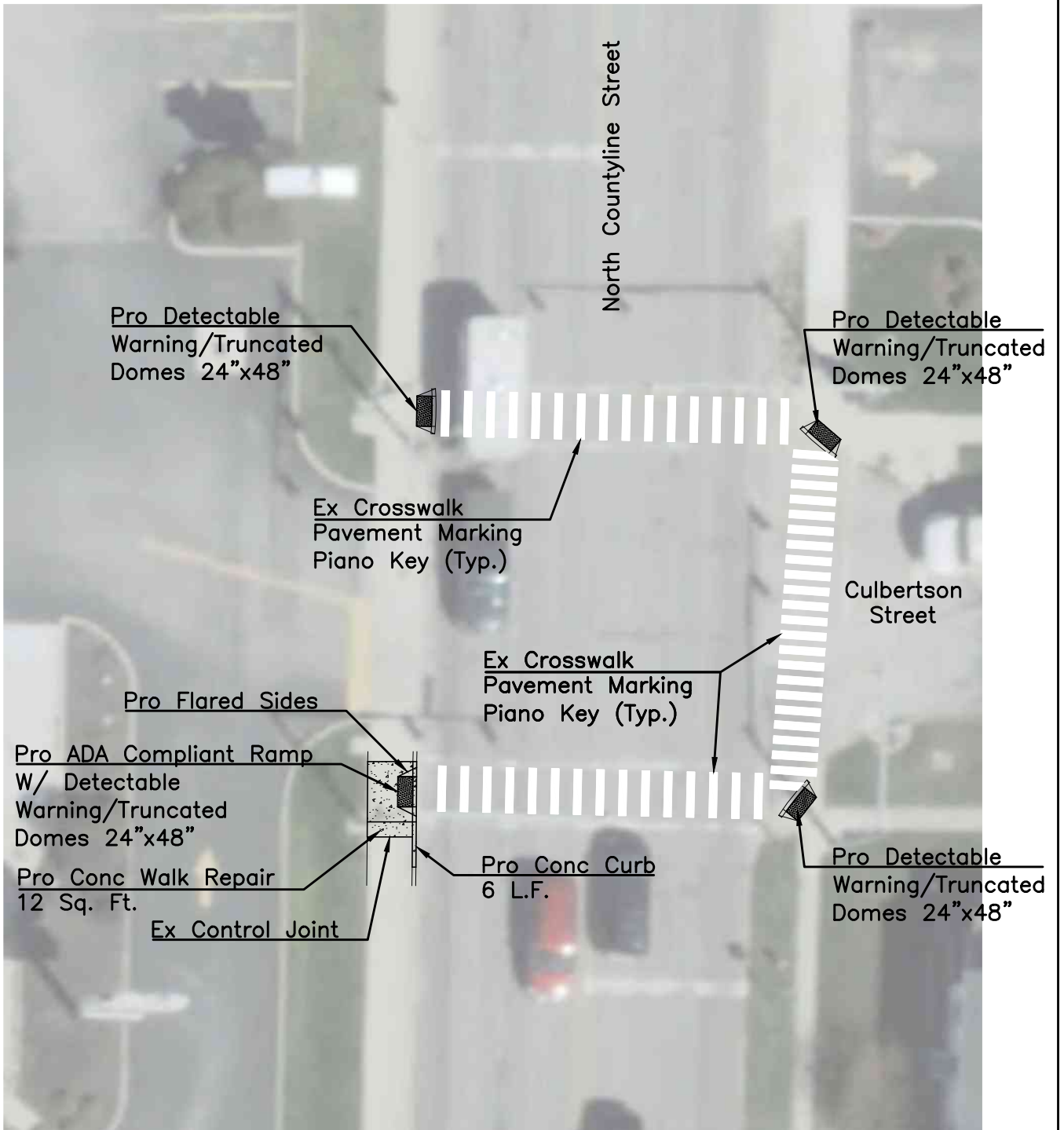

North Countyline Street and Culbertson Street



Northwest Corner of North Countyline Street and Culbertson Street



Southwest Corner of North Countyline Street and Culbertson Street



Northeast Corner of North Countyline Street and Culbertson Street



Southeast Corner of North Countyline Street and Culbertson Street

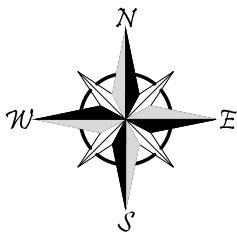
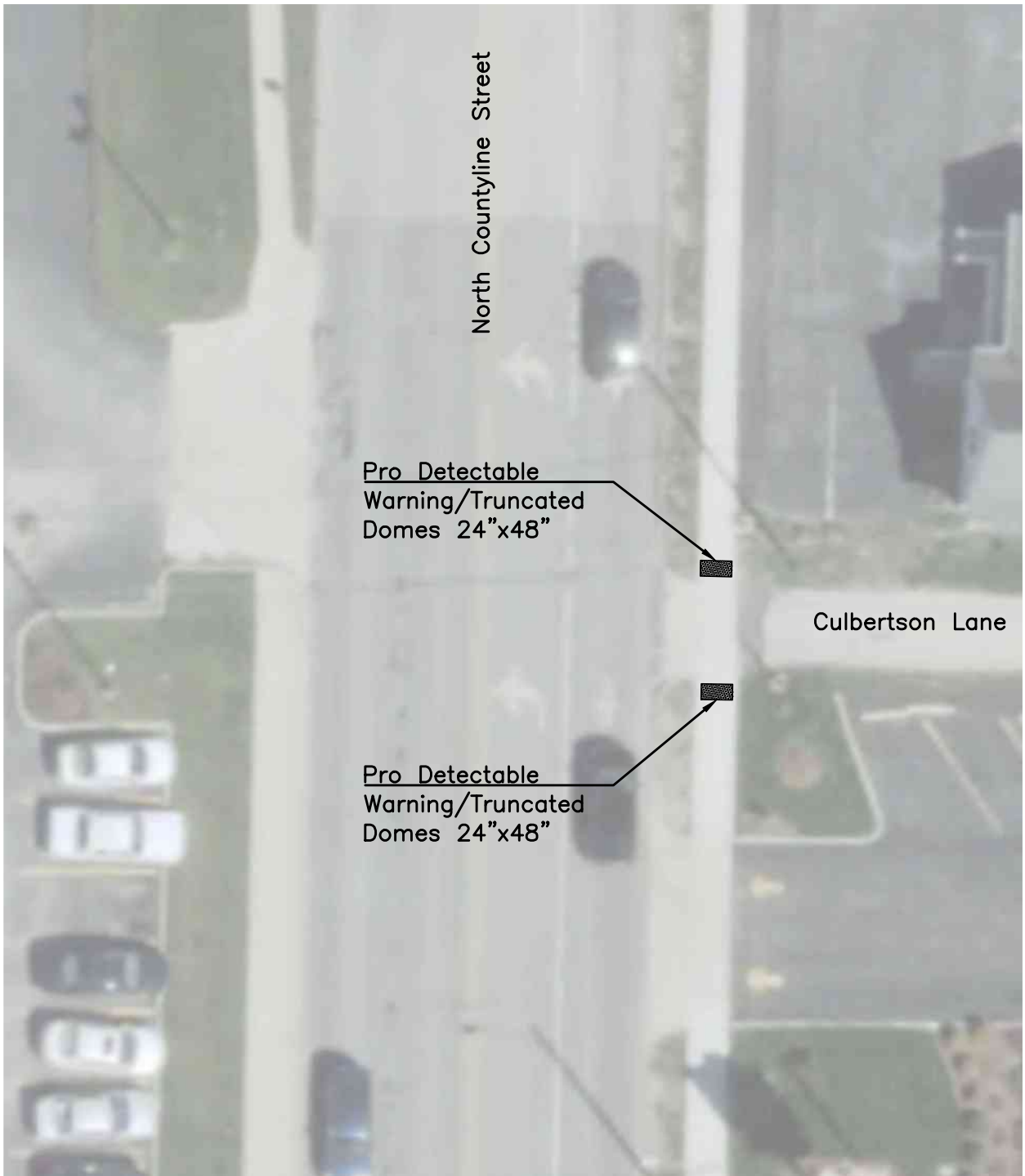

North Countyline Street and Culbertson Lane



Northeast and Southeast Corner of North Countyline Street and Culbertson Lane

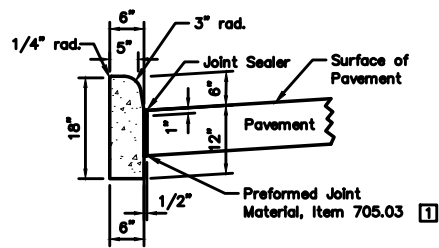

TYPE 6

2'-6" unless otherwise shown on plans

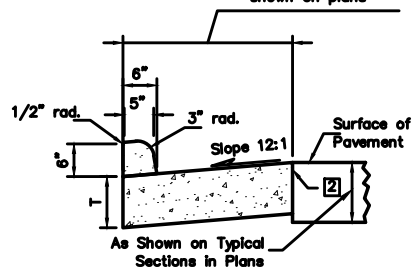

TYPE 2

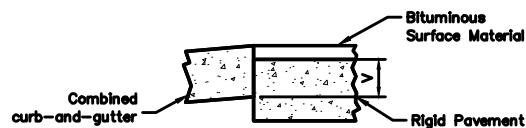

NOTES

GENERAL: This drawing shows alternate types of curb that may be used on various types of pavement. The typical section of the project shows the type to be used, also the thickness of the edge of the pavement or the edge of the curb and gutter section.

JOINTS: 1" expansion joints shall extend up to the top of the curb and shall be constructed in the curb and gutter section in such a manner that the joint seal will extend the full width of the gutter and into the curb face a sufficient distance to seal the joint to an elevation of a least 2" above the flow line of the gutter. Dowel bars shall be used in the curb and gutter section at expansion joints and to the surface of the pavement.

Transverse expansion joint material shall meet the requirements of Item 705.03.

GUTTER PLATE THICKNESS: Thickness of gutter plate "T" shall be 9" unless otherwise shown on the plans.

TOLERANCES: Dimensional tolerances are as follows:
Curbs: -1/32" to +"
Gutters: 0 to +"

All work shall conform to ODOT Item 609

Note: Height of Type 6 Curb outside of ramp areas shall match height of existing curb.

LEGEND

1 Expansion joint material and joint sealer are not required for the portion of the curb that is adjacent to a flexible pavement type. Both materials are required, as detailed, for the full height of rigid pavement and concrete bases.

2 Butt joints shall be provided between combined curb-and-gutter and new or existing rigid pavements, with tie bars or hook bolts provided at intervals of 5'. See SCD BP-2.1 for details of tie bars and hook bolts.

If the combined curb-and-gutter adjoins a new rigid base or an existing rigid base or pavement that is to be surfaced with bituminous material, a butt joint shall also be provided. However, tie bars or hook bolts shall be omitted when the vertical overlap ("V" in detail below) between the curb-and-gutter and rigid pavement is less than 7".

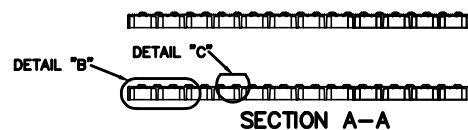
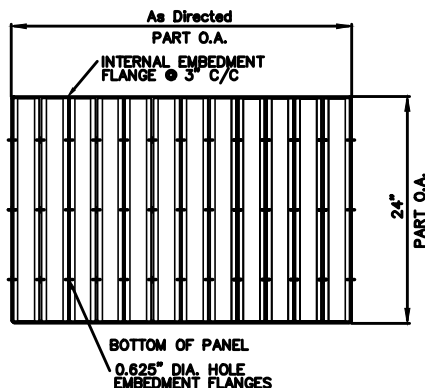
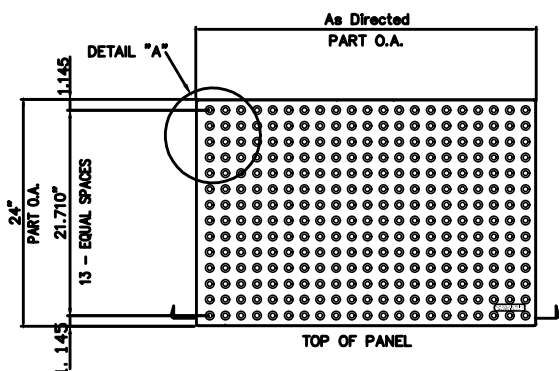

SECTION A-A

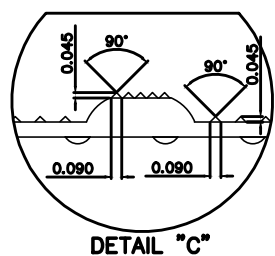

DETAIL "C"

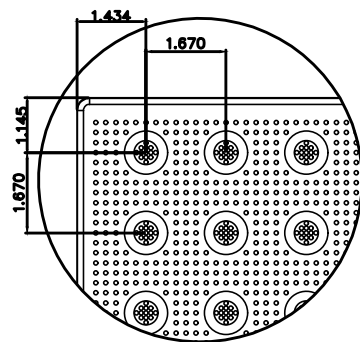

DETAIL "A"

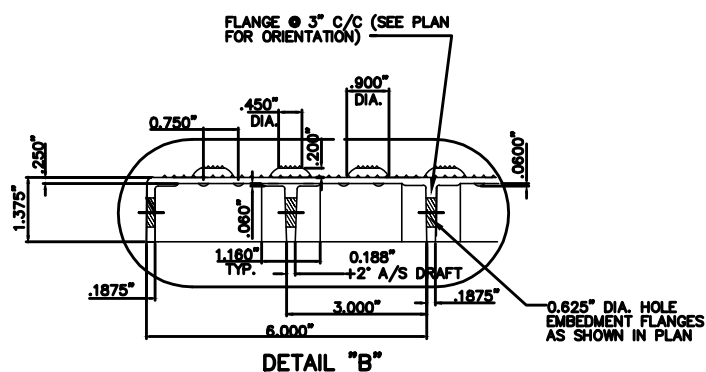

DETAIL "B"

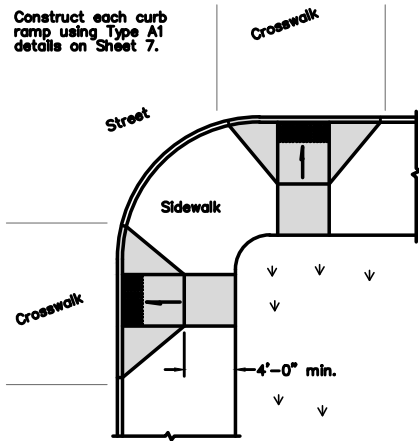

Use curb ramps with flared sides at locations with wide sidewalks.

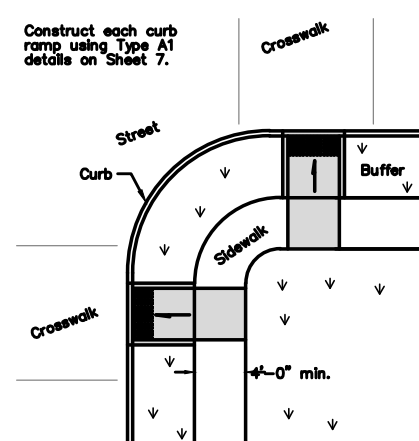

Use curb ramps with returned curbs where buffer is wide enough to accommodate ramp slope.

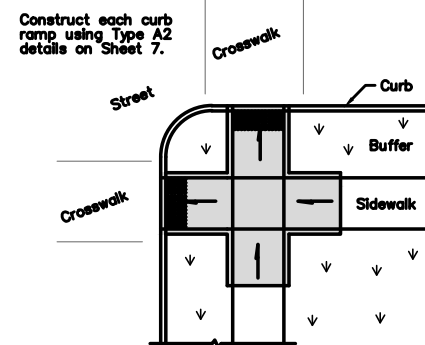

PERPENDICULAR CURB RAMPS

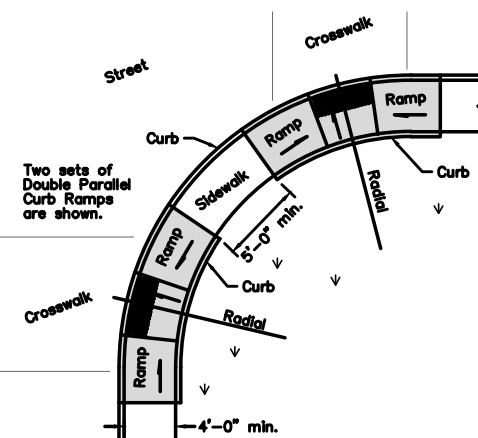

Place on streets having wide turning radius and where sidewalks are narrow.

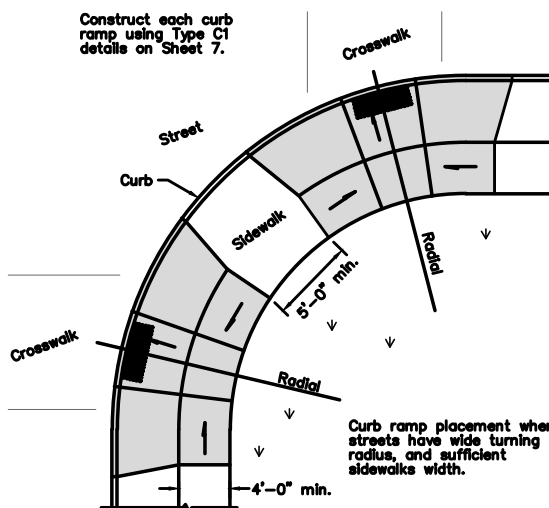

PARALLEL CURB RAMPS
PREFERRED CONSTRUCTION PLACEMENT

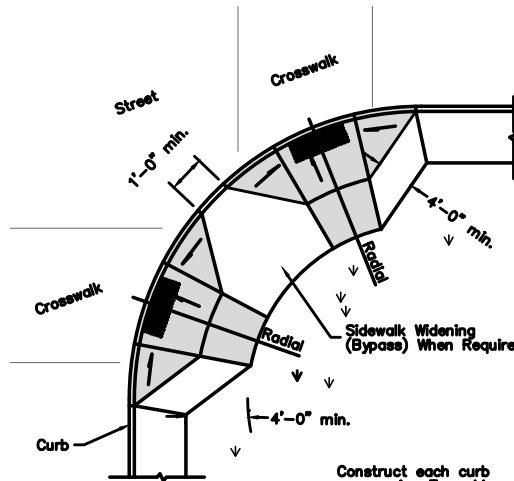

Acceptable design on corners with wide turning radius where user is able to maneuver within crosswalk limits so as not to encroach into adjacent traveled lanes.

PERPENDICULAR RAMPS

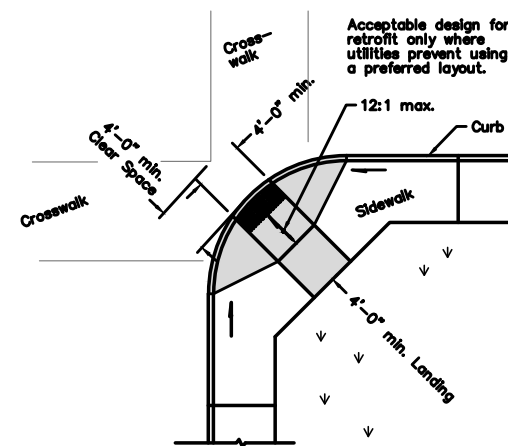

Use this design only for existing walks, and when site constraints prohibit other designs. The diagonal Type D ramp may be constructed as either a Perpendicular, Parallel or Combination curb ramp type. Avoid using where curb radii are less than 20'-0".

DIAGONAL RAMP (Type D)

ACCEPTABLE CONSTRUCTION PLACEMENT

NOTES

GENERAL: This drawing shows curb ramp types details and placement examples for curb ramp construction, including the installation of detectable warnings.

Curb ramp types are shown on Sheet 7 and include Perpendicular, Parallel, and Combined types as specified to be constructed in the locations shown on the project plans.

Curb ramps added to an existing intersection or walk should be individually detailed on the project plans to assure that the design is appropriate for site constraints and all items can be constructed to ADA standards. The contractor may adjust the placement of curb ramps if existing field conditions warrant with the approval of the Engineer.

PAYMENT: Measure and pay for the ramp area within the shaded limits of this drawing as Item 608 Curb Ramp, Square Foot. This includes the cost of any curb or gutter, detectable warnings, landing areas and any additional materials, installation, grading, forming, and finishing required within the shaded area.

Work beyond the shaded ramp/landing area is paid for as curb (609) and walk (608). Removal of existing curb, walk (or existing curb ramps) are paid under Item 202.

For at-grade crossing locations where only detectable warnings are required in order to achieve ADA compliance, measure and pay for the strip of detectable warnings as Item 608 Detectable Warning, Square Foot. The work to cast the tiles in place will also require removal of existing pavement (Item 202) to the nearest joint, or if no joint exists, a minimum of 4 feet.

The running slope of the ramp is preferred to be 12:1 or flatter. In existing sidewalks, where the maximum ramp slope is not feasible due to site constraints (e.g. utility poles or vaults, right-of-way limits) it may be reduced as follows:

- A) 10:1 for a max. rise of 6",
- B) 8:1 for a max. rise of 3",
- C) 6:1 over a max. run of 2'-0" for historic areas where a flatter slope is not feasible.

To prevent chasing the grade indefinitely, the transition from existing sidewalk to the shaded curb ramp area is not required to exceed 15 feet in length.

While ramps may be skewed to the crosswalk, the entire lower landing area must fall within the crosswalk that the ramp serves and cannot be located in the traveled lane of opposing traffic.

The counter slope of the gutter or street at the foot of a curb ramp, landing, or blended transitions shall be 20:1 or flatter.

The bottom edge of the ramp shall change planes perpendicular to the landing.

The edge of the curb shall be flush with the edge of the adjacent pavement and gutter and surface slopes that meet grade breaks shall also be flush.

Ramp landings shall be 4' min. x 4' min. with a 50:1 or flatter cross slope and running slope.

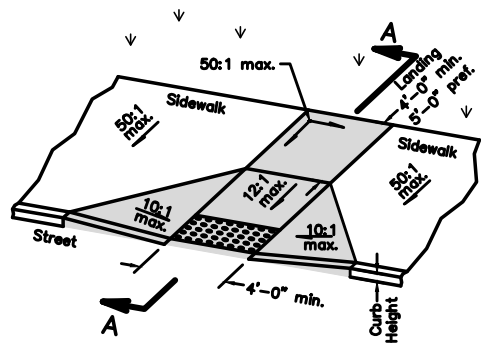

Type A1 (Perpendicular with flared sides)

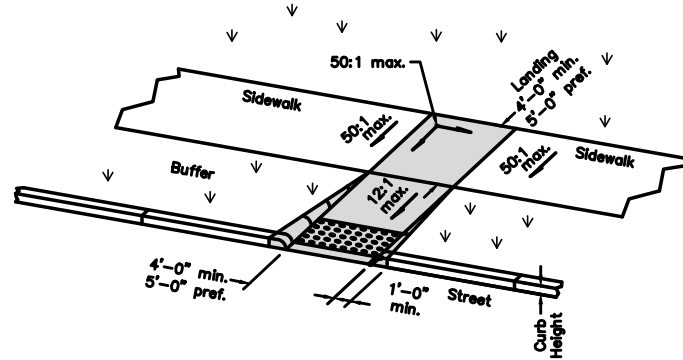

Type A2 (Perpendicular with returned curb)

PERPENDICULAR CURB RAMP DETAILS

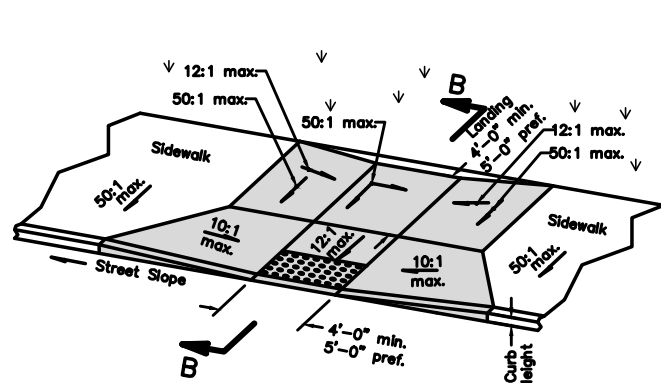

Type C1 (Combined with flared sides)

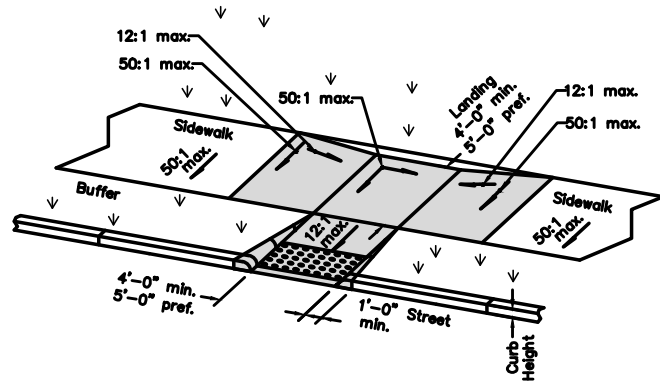

Type C2 (Combined with returned curb)

COMBINED CURB RAMP DETAILS

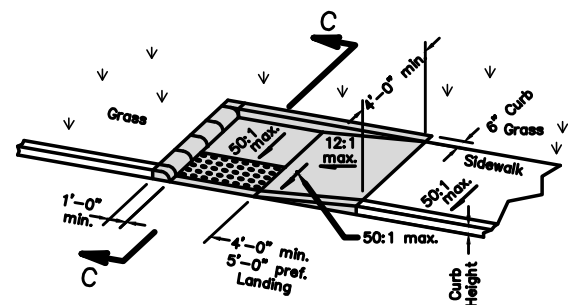

Type B1 (Single sided Parallel)

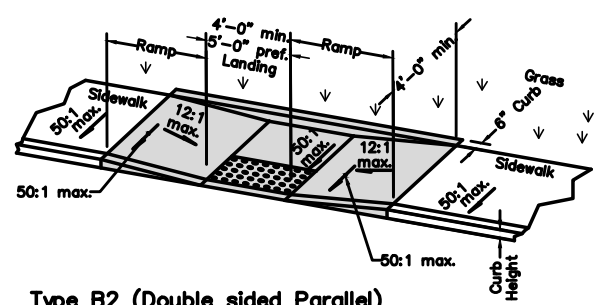

Type B2 (Double sided Parallel)

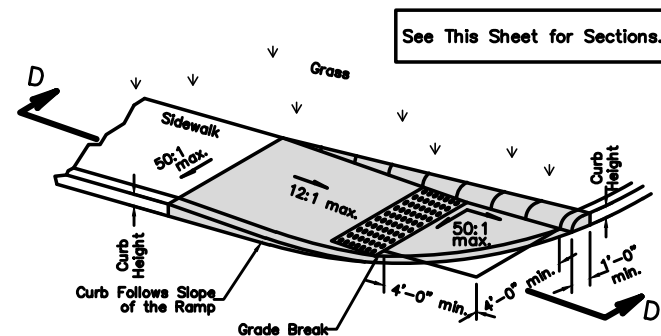

Type B3 (Single sided Parallel)

PARALLEL CURB RAMP DETAILS

See This Sheet for Sections.

NOTES CONTINUED

DETECTABLE WARNINGS: Install Detectable Warnings on each curb ramp with approved materials, as shown on this sheet. Install these proprietary products as per manufacturer's written instructions.

DRAINAGE: Contractor is to ensure the base of each constructed curb ramp allows for proper drainage, without exceeding allowable cross slope or ramp slopes. Vertical change in level exceeding 1/8" between the 1) pavement and gutter, and 2) gutter and ramp, are not allowed.

SURFACE TEXTURE: Texture concrete surfaces by coarse brooming transverse to the ramp slopes to be rougher than the adjacent walk.

JOINTS: Provide expansion joints in the curb ramp as extensions of walk joints and consistent with Item 808.03 requirements for a new concrete walk. Provide a 1/2" Item 705.03 expansion joint filler around the edge of ramps built in existing concrete walks. Lines shown on this drawing indicate the ramp edges and slope changes, and do not necessarily indicate joint lines.

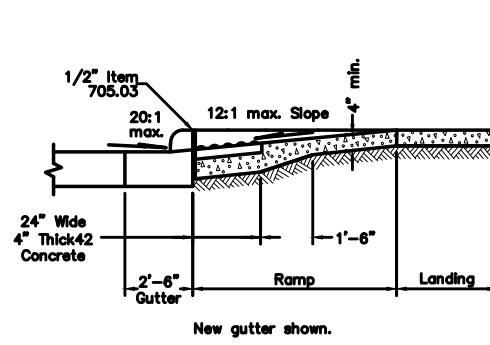

SECTION A-A
NORMAL DETAIL

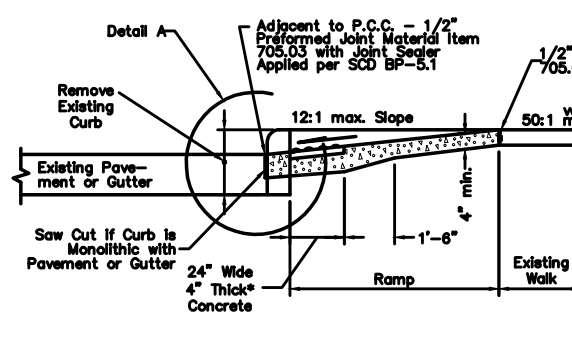

SECTION A-A
EXISTING WALK DETAIL

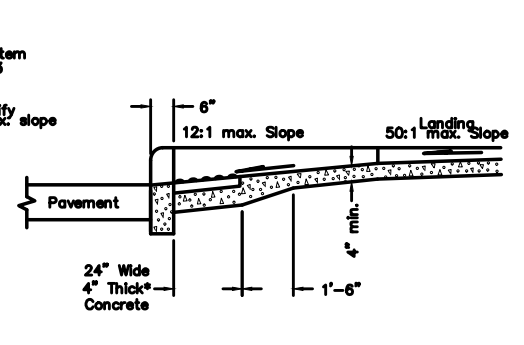

SECTION B-B

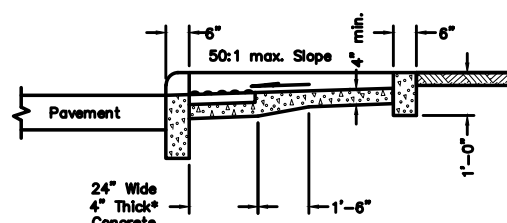

SECTION C-C

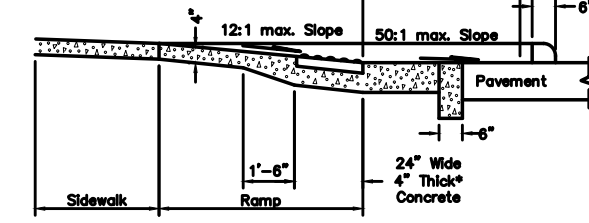

SECTION D-D

*Where possible, pour ramp area integral with the curb, otherwise use 6" thick walk.

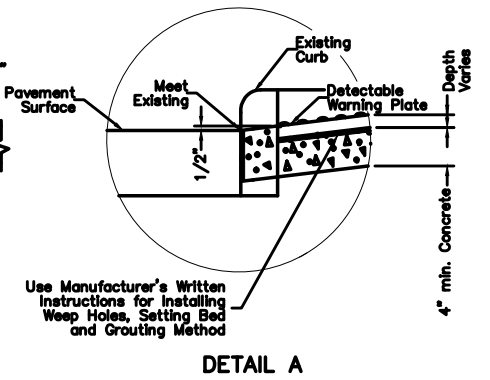

DETAIL A

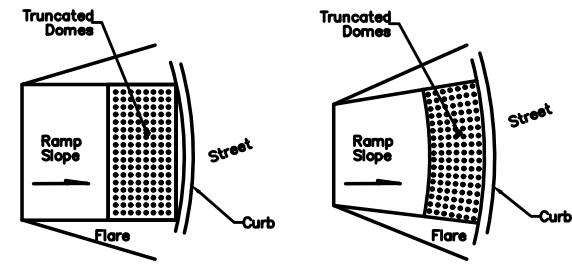

DOME ALIGNMENT ON RADIUS CURB

DETECTABLE WARNINGS NOTES

Detectable Warnings are a distinctive surface pattern of truncated domes which are detectable by cane or underfoot to alert people with vision impairments of their approach to streets and hazardous drop-offs.

Detectable warnings are to be installed at any location where pedestrians might cross paths with vehicular traffic lanes, such as the base of curb ramps or at blended curbs. A 24" strip of domes is to be installed for the full width of the ramp or walk. Typical street corner placement locations are shown on Sheet 6.

The depth of concrete underneath detectable warning products shall be a minimum of 4". See DETAIL A.

Truncated domes should be aligned with the primary direction of the ramp as shown on the DETECTABLE WARNING ALIGNMENT Detail. Normally the detectable warnings should be flush with the back of the curb, but for skewed conditions see DETECTABLE WARNING ALIGNMENT Detail. For non-standard layouts, detectable warning materials may have to be mitered and placed segmentally.

Color of the detectable warnings should contrast with surrounding concrete walk and ramp. Black is not an acceptable color. Approved products and guidance on color may be found on the Office of Roadway Engineering Service's Detectable Warnings Approved List. Install products as per manufacturer's printed instructions.

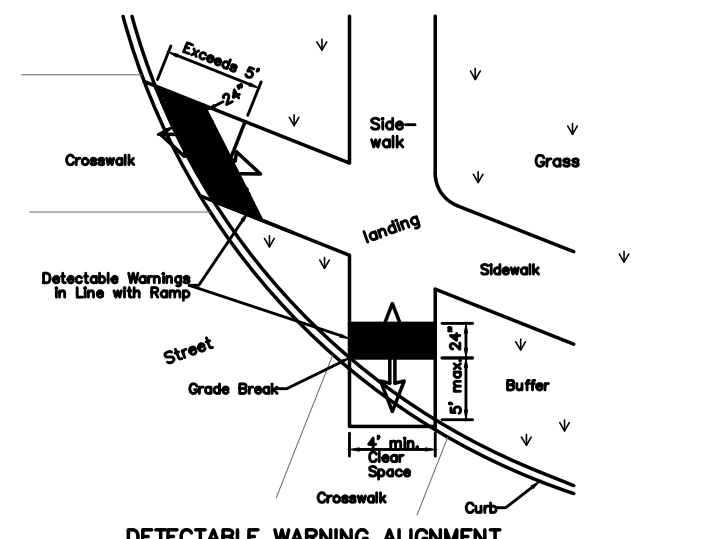
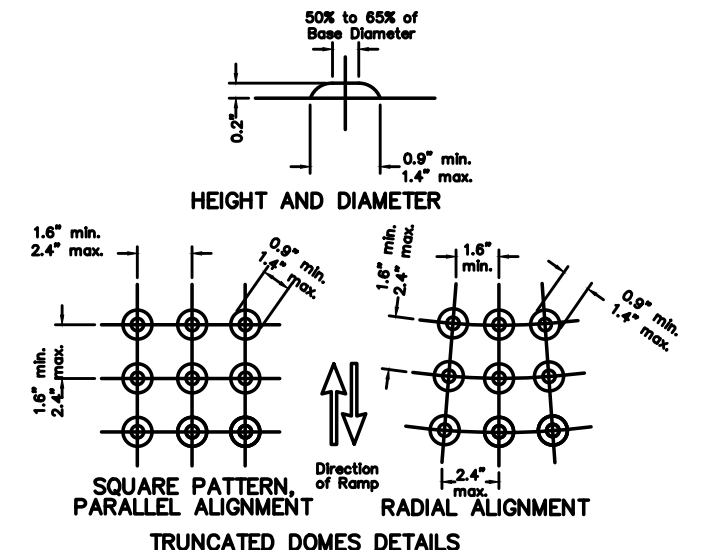

DETECTABLE WARNING ALIGNMENT